



**MITSUBISHI
ELECTRIC**

Safety Guidelines

Thank you for purchasing the Mitsubishi programmable controller MELSEC-L series.

Prior to use, please read this and relevant manuals thoroughly to fully understand the product.

Mitsubishi Programmable
Controller

MELSEC *L* series



MODEL	LCPU-U-HW
MODEL CODE	13J240
IB(NA)-0800456-N(1510)MEE	

● SAFETY PRECAUTIONS ●

(Read these precautions before using this product.)

Before using the MELSEC-L series products, please read this manual and the relevant manuals carefully and pay full attention to safety to handle the product correctly.

In this manual, the safety precautions are classified into two levels:

" WARNING" and " CAUTION".

WARNING

Indicates that incorrect handling may cause hazardous conditions, resulting in death or severe injury.

CAUTION

Indicates that incorrect handling may cause hazardous conditions, resulting in minor or moderate injury or property damage.

Under some circumstances, failure to observe the precautions given under " CAUTION" may lead to serious consequences.

Observe the precautions of both levels because they are important for personal and system safety.

Make sure that the end users read this manual and then keep the manual in a safe place for future reference.

All safety precautions for the MELSEC-L series products are described in this manual.

[Design Precautions]

WARNING

- Configure safety circuits external to the programmable controller to ensure that the entire system operates safely even when a fault occurs in the external power supply or the programmable controller. Incorrect output or malfunction due to a communication failure may result in an accident.
 - (1) Emergency stop circuits, protection circuits, and protective interlock circuits for conflicting operations such as forward/reverse rotations or upper/lower limit positioning must be configured external to the programmable controller.

[Design Precautions]

WARNING

- (2) Machine OPR (Original Point Return) of the CPU module's positioning function is controlled with two kinds of data: an OPR direction and an OPR speed. Deceleration starts when the near-point watchdog signal turns on. If an incorrect OPR direction is set, motion control may continue without deceleration. To prevent machine damage caused by this, configure an interlock circuit external to the programmable controller.
- (3) When the CPU module detects an error during operation of the CPU module's positioning function, the motion slows down and stops.
- (4) When the programmable controller detects an abnormal condition, it stops the operation and the output status is as follows:
 - If the overcurrent or overvoltage protection of the power supply module is activated, all outputs are turned off.
 - If the self-diagnostics function of the CPU module detects an error such as a watchdog timer error, all outputs are held unchanged or turned off according to the parameter setting.

All outputs may turn on if an error occurs in a part, such as an I/O control part, where the CPU module cannot detect any error. To ensure safety operation in such a case, provide a safety mechanism or a fail-safe circuit external to the programmable controller. For a fail-safe circuit example, refer to "GENERAL SAFETY REQUIREMENTS" in this manual.

- (5) Outputs may remain on or off due to a failure of an output circuit relay or transistor. Configure an external circuit for monitoring output signals that could cause a serious accident.
- In an output circuit, when a load current exceeding the rated current or an overcurrent caused by a load short-circuit flows for a long time, it may cause smoke and fire. To prevent this, configure an external safety circuit, such as a fuse.
 - Configure a circuit so that the programmable controller is turned on first and then the external power supply. If the external power supply is turned on first, an accident may occur due to an incorrect output or malfunction.
 - Configure a circuit so that the external power supply is turned off first and then the programmable controller.
If the programmable controller is turned off first, an accident may occur due to an incorrect output or malfunction.

[Design Precautions]

WARNING

- For the operating status of each station after a communication failure, refer to relevant manuals for the network. Failure to do so may result in an accident due to an incorrect output or malfunction.
- When changing data of a running programmable controller from a peripheral connected to the CPU module or from an external device such as a personal computer connected to an intelligent function module, configure an interlock circuit in the program to ensure that the entire system will always operate safely.

For other controls to a running programmable controller (such as program modification or operating status change), read relevant manuals carefully and ensure the safety before the operation.

Especially, in the case of a control from an external device to a remote programmable controller, immediate action cannot be taken for a problem on the programmable controller due to a communication failure. To prevent this, configure an interlock circuit in the program, and determine corrective actions to be taken between the external device and CPU module in case of a communication failure.
- An absolute position return by the CPU module's positioning function may turn off the servo-on signal (servo off) for approximately 20ms, and the motor may run unexpectedly. If this causes a problem, provide an electromagnetic brake separately to lock the motor during absolute position return.
- Do not write any data to the "system area" or "write-protect area" (R) of the buffer memory in an intelligent function module.

Also, do not turn on any "use prohibited" signal that is output from the CPU module to the intelligent function module.

Doing so may cause malfunction of the programmable controller system.
- When setting auto refresh parameters, specify "Y" for the remote output RY refresh devices. Specifying any other than "Y" (for example, M or L) will hold the previous device status in the case of a CPU stop. For information on how to stop the data link, refer to the MELSEC-L CC-Link System Master/Local Module User's Manual.
- Disconnection of a communication cable (such as a CC-Link dedicated cable) may make the line condition unstable, causing communication errors on multiple stations on the network. Configure an interlock circuit in the program so that the system will operate safely even if these communication errors occur on multiple stations. Failure to do so may result in an accident due to an incorrect output or malfunction.

[Design Precautions]

WARNING

Precautions for using digital-analog converter modules and analog input/output modules

- When a module is faulty, analog outputs may remain on. Configure an external circuit for monitoring output signals that could cause a serious accident.

Precautions for using high-speed counter modules and flexible high-speed I/O control modules

- Outputs may remain on or off due to a failure of a transistor for external output. Configure an external circuit for monitoring output signals that could cause a serious accident.

Precautions for using positioning modules

- Configure safety circuits external to the programmable controller to ensure that the entire system operates safely even when a fault occurs in the external power supply or the programmable controller. Incorrect output or malfunction due to a communication failure may result in an accident.
 - (1) Machine OPR (Original Point Return) is controlled by two kinds of data: an OPR direction and an OPR speed. Deceleration starts when the near-point watchdog signal turns on. If an incorrect OPR direction is set, motion control may continue without deceleration. To prevent machine damage caused by this, configure an interlock circuit external to the programmable controller.
 - (2) When the module detects an error, the motion slows down and stops or the motion suddenly stops, depending on the stop group setting in parameter. Set the parameter according to the positioning system specifications. In addition, set the OPR parameter and positioning data within the parameter setting range.
 - (3) Outputs may remain on or off, or be undefined due to a failure of a component such as an insulated element or transistor in an output circuit, where the CPU module cannot detect any error. Configure an external circuit for monitoring output signals in a system where an incorrect output could cause a serious accident.
- An absolute position restoration by the positioning function may turn off the servo-on signal (servo off) for approximately 60ms + scan time, and the motor may run unexpectedly. If this causes a problem, provide an electromagnetic brake to lock the motor during absolute position restoration.

[Design Precautions]

WARNING

Precautions for using flexible high-speed I/O control modules

- When changing setting data and operating status of the running module from a personal computer, configure an interlock circuit external to the programmable controller to ensure that the entire system operates safely. In addition, before performing online operations for the running module from a personal computer, determine corrective actions to be taken in case of a communication failure due to poor contact of cables.

[Design Precautions]

CAUTION

- Do not install the control lines or communication cables together with the main circuit lines or power cables. Keep a distance of 100mm or more between them. Failure to do so may result in malfunction due to noise.
- During control of an inductive load such as a lamp, heater, or solenoid valve, a large current (approximately ten times greater than normal) may flow when the output is turned from off to on. Therefore, use a module that has a sufficient current rating.
- Time from when the CPU module is powered on or is reset to when it enters in RUN status depends on the system configuration, parameter settings, and program size. Design the program so that the entire system will always operate safely, regardless of the time.

Precautions for using dual channel isolated high resolution analog-digital converter modules

- Do not install the analog signal cable together with main circuit lines, power cables, or load circuit lines of a device other than the programmable controller. Install the analog output cable 150mm away from the above lines and cables. Failure to do so may result in malfunction due to noise.

[Design Precautions]

CAUTION

Precautions for using digital-analog converter modules and analog input/output modules

- At power-on, a voltage may occur or a current may flow between output terminals for a moment. In this case, start the control after analog outputs become stable.
- Power on or off the external power supply while the programmable controller is on. Failure to do so may result in incorrect output or malfunction.

Precautions for using flexible high-speed I/O control modules

- Do not install the control lines or communication cables together with the main circuit lines or power cables. Keep a distance of 150mm or more between them. Failure to do so may result in malfunction due to noise.

[Installation Precautions]

WARNING

- Shut off the external power supply for the system in all phases before mounting or removing the module. Failure to do so may result in electric shock or cause the module to fail or malfunction.

[Installation Precautions]

CAUTION

- Use the programmable controller in an environment that meets the general specifications described in this manual. Failure to do so may result in electric shock, fire, malfunction, or damage to or deterioration of the product.
- To interconnect modules, engage the respective connectors and securely lock the module joint levers until they click. Incorrect interconnection may cause malfunction, failure, or drop of the module.
- Do not directly touch any conductive part of the module. Doing so can cause malfunction or failure of the module.
- Securely connect an extension cable to the connectors of a branch module and an extension module. After connection, check that the cable is inserted completely. Poor contact may cause malfunction.
- Securely install the SD memory card pushing the card into the SD memory card installation slot. After installation, check that the SD memory card is installed completely. Poor contact may cause malfunction.
- Do not directly touch any conductive part and electronic components of the module and the SD memory card. Doing so can cause malfunction and failure of the module and the SD memory card.

[Wiring Precautions]

WARNING

- Shut off the external power supply for the system in all phases before wiring. Failure to do so may result in electric shock or cause the module to fail or malfunction.
- After installation and wiring, attach the included terminal cover to the product before turning it on for operation. Failure to do so may result in electric shock.

Precautions for using flexible high-speed I/O control modules

- When connecting a differential output terminal to the differential receiver of a drive unit, connect a high-speed output common terminal to the common terminal of the differential receiver of the drive unit. Failure to do so may cause the module to fail or malfunction because of the potential difference that occurs between the high-speed output common terminal and the differential receiver common terminal.

[Wiring Precautions]

CAUTION

- Ground the FG and LG terminals to the protective ground conductor dedicated to the programmable controller. Failure to do so may result in electric shock or malfunction.
- Use applicable solderless terminals and tighten them within the specified torque range. If any spade solderless terminal is used, it may be disconnected when a screw on the terminal block comes loose, resulting in failure.
- Check the rated voltage and terminal layout before wiring to the module, and connect the cables correctly. Connecting a power supply with a different voltage rating or incorrect wiring may cause a fire or failure.
- Connectors for external device connection must be crimped or pressed with the tool specified by the manufacturer, or must be correctly soldered. Incomplete connections could result in short circuit, fire, or malfunction.
- Connect the connector to the module securely.
- Do not install the control lines or communication cables together with the main circuit lines or power cables. Keep a distance of 100mm or more between them. Failure to do so may result in malfunction due to noise.
- Place the cables in a duct or clamp them.
If not, dangling cables may swing or inadvertently be pulled, resulting in damage to the module or cables or malfunction due to poor connection.
- Confirm the interface type in advance and connect the cable correctly.
Connecting a cable to a different interface or incorrect wiring will cause failure of the module and the external device.
- Tighten the screws on the terminal block within the specified torque range. Undertightening can cause short circuit or malfunction. Overtightening can damage the screw and/or module, resulting in drop, short circuit, fire, or malfunction.
- When disconnecting the cable from the module, do not pull the cable by the cable part.
For a cable with connector, hold the connector by hand and pull it out. For a cable connected to a terminal block, loosen the terminal block screws first before removing the cable.
Failure to do so may result in malfunction and damage to the module or cable.
- Prevent foreign matter such as dust or wire chips from entering the module. Such foreign matter can cause a fire, failure, or malfunction.

[Wiring Precautions]

CAUTION

- A protective film is attached to the top of the module to prevent foreign matter, such as wire chips, from entering the module during wiring. Do not remove the film during wiring. Remove it for heat dissipation before system operation.
- For the CC-Link system, use dedicated cables that are specified by the manufacturer. If any other cable is used, performance of the CC-Link system is not guaranteed. Also, the maximum overall cable length and the station-to-station cable length must meet those specified in the MELSEC-L CC-Link System Master/Local Module User's Manual. If not, normal data communication is not guaranteed.
- To use the high-speed counter function of the CPU module, ground the shielded cable to the encoder (relay box). Failure to do so may cause malfunction.
- Mitsubishi programmable controllers must be installed in control panels. Connect the main power supply to the power supply module in the control panel through a relay terminal block. Wiring and replacement of a power supply module must be performed by qualified maintenance personnel who is familiar with protection against electric shock. For wiring methods, refer to the MELSEC-L CPU Module User's Manual (Hardware Design, Maintenance and Inspection).

Precautions for using high-speed counter modules

- Ground the shield cable on the encoder side (relay box). Always ground the FG and LG terminals to the protective ground conductor. Failure to do so may cause malfunction.

Precautions for using CC-Link/LT master module

- For the CC-Link/LT, use the cables specified by the CC-Link Partner Association. The performance of the CC-Link/LT cannot be assured if any other cables than the specified are used. For the network wiring, follow the specifications described in MELSEC-L CC-Link/LT Master Module User's Manual. Normal data communication is not guaranteed if the wiring is not conducted according to the specifications.

[Startup and Maintenance Precautions]

WARNING

- Do not touch any terminal while power is on. Doing so will cause electric shock or malfunction.
- Correctly connect the battery connector. Do not charge, disassemble, heat, short-circuit, solder, or throw the battery into the fire. Also, do not expose the battery to liquid or strong shock. Doing so will cause the battery to produce heat, explode, ignite, or leak, resulting in injury and fire.
- Shut off the external power supply for the system in all phases before cleaning the module or retightening the screws on the terminal block or connector screws. Failure to do so may result in electric shock.

[Startup and Maintenance Precautions]

CAUTION

- Before performing online operations (especially, program modification, forced output, and operation status change) for a running CPU module from the peripheral connected, read relevant manuals carefully and ensure the safety. Improper operation may damage machines or cause accidents.
- Do not disassemble or modify the modules. Doing so may cause failure, malfunction, injury, or a fire.
- Use any radio communication device such as a cellular phone or PHS (Personal Handy-phone System) more than 25cm away in all directions from the programmable controller. Failure to do so may cause malfunction.
- Shut off the external power supply for the system in all phases before connecting or disconnecting the module. Failure to do so may cause the module to fail or malfunction.
- Tighten the screws on the terminal block or connector screws within the specified torque range. Undertightening can cause drop of parts or wires, short circuit, or malfunction. Overtightening can damage the screw and/or module, resulting in drop, short circuit, or malfunction.
- After the first use of the module (including a display unit), the number of module connections/disconnections is limited to 50 times. Exceeding the limit (in accordance with IEC 61131-2) may cause malfunction.
- After the first use of the product, the number of SD memory card insertions/removals is limited to 500 times. Exceeding the limit may cause malfunction.

[Startup and Maintenance Precautions]

CAUTION

- Do not drop or apply shock to the battery to be installed in the module. Doing so may damage the battery, causing the battery fluid to leak inside the battery. If the battery is dropped or any shock is applied to it, dispose of it without using.
- Before handling the module, touch a conducting object such as a grounded metal to discharge the static electricity from the human body. Failure to do so may cause the module to fail or malfunction.
- Before testing the CPU module's positioning function, set a low speed value for the speed limit parameter so that the operation can be stopped immediately upon occurrence of a hazardous condition.

Precautions for using positioning modules

- Before testing the operation, set a low speed value for the speed limit parameter so that the operation can be stopped immediately upon occurrence of a hazardous condition.

Precautions for using flexible high-speed I/O control modules

- Before performing online operations for the running module from the personal computer connected, read relevant manuals carefully and ensure the safety.
- Before changing each setting of the module, read relevant manuals carefully and ensure the safety, and change the status of the CPU module to STOP.

[Operation Precautions]

CAUTION

- When controlling a running programmable controller (especially, changing data, program modification, and operation status change) from an external device such as a personal computer connected to an intelligent function module, read the relevant user's manual carefully and ensure the safety before the operation. Incorrect data change, program modification, and status control may cause malfunction of the system, mechanical damage, or accidents.
- While set values in the buffer memory are being registered to the flash ROM in the module, do not turn off the power to the module and do not reset the CPU module. Doing so will affect the flash ROM data, and setting to the buffer memory and registration to the flash ROM need to be performed again. Also, it may cause failure or malfunction of the module.

[Disposal Precautions]

CAUTION

- When disposing of this product, treat it as industrial waste. When disposing of batteries, separate them from other wastes according to the local regulations. (For details of the Battery Directive in EU member states, refer to the MELSEC-L CPU Module User's Manual (Hardware Design, Maintenance and Inspection).)

[Transportation Precautions]

CAUTION

- When transporting lithium batteries, follow the transportation regulations. (For details of the regulated models, refer to the MELSEC-L CPU Module User's Manual (Hardware Design, Maintenance and Inspection).)

● PRÉCAUTIONS DE SÉCURITÉ ●

(Lire ces précautions avant toute utilisation du produit.)

Avant d'utiliser les produits de la série MELSEC-L, lire attentivement ce manuel et les autres manuels correspondants en prêtant une attention particulière à ce qui a trait à la sécurité du produit.

Dans ce manuel, les précautions de sécurité sont classées en deux niveaux, à savoir : "⚠ AVERTISSEMENT" et "⚠ ATTENTION"

⚠ AVERTISSEMENT

Attire l'attention sur le fait qu'une négligence peut créer une situation de danger avec risque de mort ou de blessures graves.

⚠ ATTENTION

Attire l'attention sur le fait qu'une négligence peut créer une situation de danger avec risque de blessures légères ou de gravité moyennes ou risque de dégâts matériels.

Dans certaines circonstances, le non-respect d'une précaution de sécurité introduite sous le titre "⚠ ATTENTION" peut avoir des conséquences graves. Les précautions de ces deux niveaux doivent être observées dans leur intégralité car elles ont trait à la sécurité des personnes et aussi du système.

Veiller à ce que les utilisateurs finaux lisent ce manuel qui doit être conservé soigneusement à portée de main pour s'y référer autant que de besoin.

Toutes les précautions de sécurité à observer pour les produits de la série MELSEC-L sont présentées dans ce manuel.

[Précautions lors de la conception]

⚠ AVERTISSEMENT

- Configurer des circuits de sécurité extérieurs à l'automate programmable pour garantir la sécurité du système dans son ensemble à la survenance d'une anomalie dans l'alimentation externe comme dans l'automate programmable. Une sortie erronée ou un dysfonctionnement suite à une erreur de communication peuvent être à l'origine d'un accident.
(1) Les circuits d'arrêt d'urgence, les circuits de protection et les circuits de verrouillage de sécurité pour les opérations contradictoires du genre rotation avant/arrière ou positionnement en limite haute/basse doivent être configurés à l'extérieur de l'automate programmable.

 **AVERTISSEMENT**

- (2) L'OPR machine (retour au point origine) de la fonction de positionnement du module CPU se commande par deux sortes de données : sens vers OPR et vitesse vers OPR. La décélération commence à l'apparition du signal de surveillance d'approche. Si l'indication du sens vers l'OPR est erronée, la commande de mouvement continue sans décélération. Pour éviter l'endommagement de la machine dans une telle éventualité, constituer un circuit de verrouillage extérieur à l'automate programmable.
- (3) Si le module CPU détecte une erreur pendant l'exécution d'une fonction de positionnement par module CPU, le mouvement est décéléré jusqu'à l'arrêt.
- (4) Lorsque l'automate programmable détecte une situation anormale, il interrompt la marche et l'état des sorties est comme indiqué ci-après.
 - Au déclenchement d'une protection contre surintensité ou surtension dans le module d'alimentation, toutes les sorties sont mises hors service.
 - Si la fonction d'auto-diagnostic du module CPU détecte une erreur telle qu'une erreur d'horloge de surveillance, toutes les sorties peuvent être maintenues sans changement ou mises hors service par le paramétrage.

Toutes les sorties pourraient rester actives si l'erreur s'est produite dans une partie comme un organe d'entrée/sortie dont le module CPU ne peut pas détecter les erreurs. Pour garantir la sécurité en exploitation dans une telle éventualité, il faut donc prévoir un mécanisme de sécurité ou un circuit de mise en sécurité à l'extérieur de l'automate programmable. On trouvera un exemple de circuit de mise en sécurité à la rubrique "EXIGENCES GÉNÉRALES DU POINT DE VUE DE LA SÉCURITÉ" du présent manuel.

- (5) Après défaillance d'un relais ou d'un transistor de circuit de sortie, les sorties peuvent restées à l'état actif ou inactif. Configurer un circuit de surveillance externe pour le suivi des signaux de sortie susceptibles de provoquer un accident grave.
- Dans un circuit de sortie, si le courant de charge excède la valeur nominale ou si une surintensité causée par un court-circuit à la charge persiste longtemps, il peut en résulter un dégagement de fumée avec départ de feu. Pour éviter cela, il faut configurer un circuit de sécurité, avec un fusible par exemple.
 - Configurer le circuit de façon à allumer d'abord l'automate programmable avant l'alimentation externe. Si on commence par brancher l'alimentation externe, ceci peut être une cause d'accident en cas de sortie incorrecte ou autre dysfonctionnement.



AVERTISSEMENT

- *Configurer un circuit qui coupera d'abord l'alimentation externe puis l'automate programmable. Si c'est l'automate programmable qui est mis hors tension en premier, il y a risque d'accident en cas de sortie erronée ou autre dysfonctionnement.*
- *Quant à l'état opérationnel de chacune des stations en cas de problème de communication, voir les manuels correspondants pour le réseau. Faute de quoi, une instruction de sortie incorrecte ou un dysfonctionnement pourrait être à l'origine d'un accident.*
- *Pour pouvoir procéder à des changements de données sur un automate programmable en marche à partir d'un périphérique connecté au module CPU ou à partir d'un ordinateur individuel connecté à un module fonctionnel intelligent, prévoir dans le programme un circuit de verrouillage permettant d'assurer en tous temps la sécurité de l'ensemble du système.
Pour les autres interventions sur un automate programmable en marche (comme par exemple une modification de programme de la station maître ou un changement d'état fonctionnel), procéder comme indiqué dans les manuels correspondants et faire les contrôles de sécurité avant d'opérer.
En particulier, lorsqu'un automate programmable distant est commandé à partir d'un dispositif externe, il faut tenir compte du fait qu'aucune action immédiate ne sera possible s'il y a un problème de communication avec l'automate programmable. Pour éviter cela, constituer un circuit de verrouillage dans le programme, et déterminer quelles seront les mesures correctives à prendre en cas de problème de communication entre le dispositif externe et le module CPU.*
- *Le retour en position absolue par la fonction de positionnement du module CPU peut entraîner une suspension du signal servo (servo off) d'une durée de l'ordre de 20ms pendant lesquelles le moteur pourrait se mettre en marche inopinément. Si cela pose problème, prévoir un frein électromagnétique pour bloquer le moteur pendant le retour en position absolue.*
- *N'introduire aucune donnée dans les zones réservées "system area" ou "write-protect area" (R) de la mémoire-tampon d'un module fonctionnel intelligent.
En outre, comme signal de sortie du module CPU vers le module fonctionnel intelligent, il ne faut utiliser aucun des signaux dont l'usage est interdit ("use prohibited").
Faute de quoi, il y aura des dysfonctionnements dans le système de l'automate programmable.*

 **AVERTISSEMENT**

- *Au paramétrage de la réactualisation automatique, sélectionner le dispositif "Y" comme dispositifs de réactualisation (RY) de sortie distante. Si on sélectionne un dispositif autre que "Y" (comme M ou L), le module CPU maintient l'état antérieur du dispositif lors des arrêts CPU. À propos de l'interruption de la liaison de données, voir le Manuel de l'utilisateur des modules maître/local du système MELSEC-L CC-Link.*
- *Le débranchement d'un câble de communication (comme un câble dédié CC-Link) peut rendre la ligne instable et entraîner des erreurs de communications dans de multiples stations du réseau. Constituer un circuit de verrouillage dans le programme permettant de maintenir la sécurité de fonctionnement du système même en cas d'erreurs de communications sur de multiples stations. Faute de quoi, une instruction de sortie incorrecte ou un dysfonctionnement pourrait être à l'origine d'un accident.*

Précautions d'utilisation des modules convertisseurs numériques-analogiques et des modules d'entrée/sortie analogiques

- *En cas de défaillance d'un module, il se peut que les sorties analogiques restent actives. Configurer un circuit de surveillance externe pour le suivi des signaux de sortie susceptibles de provoquer un accident grave.*

Précautions pour l'utilisation des modules de comptage haute vitesse et des modules de commande E/S flexibles haute vitesse

- *Les sorties peuvent rester en service ou hors service dans le cas d'une panne de transistor vers sortie externe. Configurer un circuit de surveillance externe pour le suivi des signaux de sortie susceptibles de provoquer un accident grave.*



AVERTISSEMENT

Précautions d'utilisation des modules de positionnement

- *Configurer des circuits de sécurité extérieurs à l'automate programmable pour garantir la sécurité du système dans son ensemble à la survenance d'une anomalie dans l'alimentation externe comme dans l'automate programmable. Une sortie erronée ou un dysfonctionnement suite à une erreur de communication peuvent être à l'origine d'un accident.*
 - (1) *L'OPR machine (retour au point origine) se commande par deux sortes de données : sens vers OPR et vitesse vers OPR. La décélération commence à l'apparition du signal de surveillance d'approche. Si l'indication du sens vers l'OPR est erronée, la commande de mouvement continue sans décélération. Pour éviter l'endommagement de la machine dans une telle éventualité, constituer un circuit de verrouillage extérieur à l'automate programmable.*
 - (2) *À la détection d'une erreur par le module CPU, l'arrêt se fera avec décélération ou sera un arrêt brusque, selon le paramétrage du groupe des paramètres d'arrêt. Faire le paramétrage en fonction des spécifications du système de positionnement. De plus, régler les paramétrages OPR et les données de positionnement en restant à l'intérieur des plages de paramétrage possible.*
 - (3) *Les sorties peuvent rester actives ou inactives ou dans un état instable suite à la défaillance d'un composant comme un élément isolé ou un transistor de circuit de sortie pour lequel le module CPU ne peut pas détecter les erreurs. Configurer un circuit externe pour la surveillance des signaux de sortie pour toute système dans lequel une sortie erronée pourrait avoir de graves conséquences.*
- *Le retour en position absolue par la fonction de positionnement peut entraîner une suspension du signal servo (servo off) d'une durée de l'ordre de 60ms + temps de balayage pendant lesquelles le moteur pourrait se mettre en marche inopinément. Si cela pose problème, prévoir un frein électromagnétique pour bloquer le moteur pendant le retour en position absolue.*

[Précautions lors de la conception]

AVERTISSEMENT

Précautions pour l'utilisation des module de commande E/S flexibles haute vitesse

- *Pour pouvoir changer à partir d'un ordinateur personnel le paramétrage et l'état fonctionnel du module pendant la marche, configurez un circuit de sécurité extérieur à l'automate programmable et permettant de garantir la sécurité de fonctionnement de l'ensemble du système.
De plus, avant d'effectuer toute opération en ligne sur le module en marche à partir d'un ordinateur individuel, prévoir les mesures correctives à prendre dans l'éventualité d'une panne de communication par suite de mauvais contact des câbles.*

[Précautions lors de la conception]

ATTENTION

- Ne pas entremêler les lignes de commandes ou câbles de communication avec les lignes des circuits principaux ou les câbles d'alimentation. Les installer en maintenant entre eux une distance minimum de 100 mm. Faute de quoi, il y a risque de dysfonctionnement par un bruit.
- À la commande d'une charge inductive comme une lampe, un réchauffeur ou une électrovanne, un fort courant (jusqu'à 10 fois l'intensité normale) traverse la sortie quand celle-ci passe de OFF à ON.
Il faut donc que le module utilisé ait une capacité de courant suffisante.
- Le délai entre la mise sous tension ou la réinitialisation du module CPU et son entrée en état RUN dépend de la configuration du système, du paramétrage et de la taille du programme. Concevoir le programme de manière que tout le système fonctionne en sécurité, indépendamment de ce délai.

Précautions d'utilisation des modules convertisseurs numériques-analogiques haute résolution avec isolation et double voie

- Ne pas installer le câble des signaux analogiques au voisinage de lignes du circuit principal, de câbles d'alimentation ou de lignes de circuit de charge d'un dispositif autre que l'automate programmable. Installer les câbles de sortie analogique à une distance d'au moins 150 mm des dits câbles et lignes. Faute de quoi, il y a risque de dysfonctionnement par un bruit.

Précautions d'utilisation des modules convertisseurs numériques-analogiques et des modules d'entrée/sortie analogiques

- À la mise sous tension, il peut y avoir une tension ou un courant transitoire entre bornes de sortie. Dans ce cas, ne faire démarrer la régulation qu'après la stabilisation des sorties analogiques.
- L'alimentation externe doit être établie et coupée avec l'automate programmable en marche. Faute de quoi, il pourrait y avoir des erreurs ou d'autres dysfonctionnements.

Précautions pour l'utilisation des module de commande E/S flexibles haute vitesse

- Ne pas entremêler les lignes de commandes ou câbles de communication avec les lignes des circuits principaux ou les câbles d'alimentation. Les installer en maintenant entre eux une distance minimum de 150 mm. Faute de quoi, il y a risque de dysfonctionnement par un bruit.

[Précautions d'installation]

AVERTISSEMENT

- *Couper l'alimentation externe du système sur toutes les phases avant la mise en place ou le retrait du module. Faute de quoi, il y a risque d'électrocution et le module risque de tomber en panne ou de mal fonctionner.*

[Précautions d'installation]

ATTENTION

- *Utiliser l'automate programmable dans un environnement en conformité avec les spécifications générales que présente ce manuel. Faute de quoi, il a risque d'électrocution, de départ de feu, de dysfonctionnement, d'endommagement ou de détérioration du produit.*
- *Pour l'interconnexion des modules, enficher les connecteurs respectifs et engager les loquets de module jusqu'à encliquètement. Une interconnexion imparfaite peut être à l'origine de dysfonctionnements, de pannes ou de chutes de modules.*
- *Éviter tout contact direct avec les parties conductrices du module. Une manipulation incorrecte peut être à l'origine de dysfonctionnements ou de pannes du module.*
- *Raccorder fermement une câble de rallonge aux connecteurs du sous-module et du module d'extension. Après raccordement, vérifier que le câble est bien enfiché. Tout mauvais contact peut être source de dysfonctionnements.*
- *Introduire fermement la carte-mémoire SD en la poussant à fond dans le panier à l'emplacement pour carte-mémoire SD. Après la pose, vérifier que la carte-mémoire SD est bien en place. Un mauvais contact peut être à l'origine de dysfonctionnements.*
- *Éviter tout contact direct avec les parties conductrices et les composants électroniques du module et de la carte-mémoire SD. Cela pourrait être à l'origine de dysfonctionnements ou d'une panne du module ou de la carte-mémoire SD.*

[Précautions de câblage]



AVERTISSEMENT

- *Couper l'alimentation externe du système sur toutes les phases avant de commencer à câbler. Faute de quoi, il y a risque d'électrocution et le module risque de tomber en panne ou de mal fonctionner.*
- *Après installation et câblage, mettre en place les couvre-bornes fournis avec le produit avant la mise sous tension et la mise en service. Faute de quoi, il y a risque d'électrocution.*

Précautions pour l'utilisation des module de commande E/S flexibles haute vitesse

- *Pour raccorder une borne de sortie différentielle au récepteur différentiel d'une unité motrice, connecter une des bornes communes de sortie haute vitesse à la borne commune du récepteur différentiel de l'unité motrice. Faute de quoi, il y a risque de panne ou de dysfonctionnement du module en raison de la différence de potentiel entre la borne commune de sortie haute vitesse et la borne commune du récepteur différentiel.*

 **ATTENTION**

- *Mettre à la masse les bornes FG et LG sur le conducteur réservé à la protection à la terre de l'automate programmable. Faute de quoi, il y a risque d'électrocution et de dysfonctionnement.*
- *Utiliser des bornes sans soudure de type approprié et serrer au couple de serrage prescrit. Si on utilise des bornes sans soudure de type embrochable, il y a risque de déconnexion et de panne au cas où une vis de borne se desserrerait.*
- *Vérifier la tension nominale et l'affectation des bornes avant le câblage du module et raccorder les câbles correctement. Le raccordement d'une alimentation d'une tension autre que la tension nominale ou une erreur de câblage peut être à l'origine d'un départ de feu ou d'une panne.*
- *Les connecteurs pour dispositifs externes doivent être sertis en utilisant l'outil prescrit par le fabricant ou, à défaut, ils seront correctement brasés. Une connexion imparfaite peut être à l'origine d'un court-circuit ou d'un départ de feu, ou entraîner des dysfonctionnements.*
- *Enficher le connecteur fermement sur le module.*
- *Ne pas entremêler les lignes de commandes ou câbles de communication avec les lignes des circuits principaux ou les câbles d'alimentation. Les installer en maintenant entre eux une distance minimum de 100 mm. Faute de quoi, il y a risque de dysfonctionnement par un bruit.*
- *Les câbles doivent être placés dans un conduit de câbles ou doivent être attachés.
Faute de quoi, le ballottement ou le déplacement des câbles pourrait endommager le module ou les câbles et être à l'origine de dysfonctionnements par mauvais contact.*
- *Vérifier au préalable le type d'interface et raccorder le câble correctement. Le raccordement d'un câble sur la mauvaise interface ou une erreur de câblage peuvent être d'une panne du module et du dispositif externe.*
- *Serrer les vis de la plaque à bornes dans les limites des couples de serrage prescrit. Un serrage insuffisant peut être à l'origine d'un court-circuit ou de dysfonctionnements. Un serrage excessif peut endommager les vis et/ou le module, avec aussi un risque de chute, de court-circuits et de dysfonctionnements.*

 ATTENTION

- *Pour débrancher le câble du module, ne tirer directement sur le câble proprement dit.
Si le câble a un connecteur, saisir le connecteur au main et débrancher en tirant par le connecteur. Pour un câble raccordé sur une plaque à bornes, desserrer la vis de la borne.
Faute de quoi, on pourrait endommager le module ou le câble et créer un risque de dysfonctionnement.*
- *Veiller à ne pas laisser la poussière, les copeaux métalliques ou d'autres corps étrangers pénétrer dans le module. De telles corps étrangers peuvent être à l'origine d'un départ de feu, d'une panne ou d'un dysfonctionnement.*
- *Le haut du module est recouvert d'un film protecteur pour éviter toute pénétration de corps étrangers comme des copeaux métalliques pendant le câblage du module. Ne pas retirer le film protecteur avant de terminer le câblage. Il doit cependant être retiré avant la mise en service du système pour une meilleure dispersion de la chaleur.*
- *Pour le système CC-Link, utiliser les câbles dédiés préconisés par le fabricant. Avec tout autre type de câble, les performances ne peuvent être garanties. De plus, la longueur totale de câbles et la longueur des câbles de station à station doivent être en conformité avec les prescriptions du Manuel de l'utilisateur des modules maîtres/locaux pour système MELSEC-L CC-Link. Sinon, la communication normales des données ne peut être garantie.*
- *Pour utiliser la fonction de comptage haute-vitesse du module CPU, mettre le câble blindé à la masse sur le décodeur (boîte à relais). Le non-respect de cette précaution expose à des dysfonctionnements.*
- *Les automates programmable Mitsubishi doivent être installés en tableau ou armoire de commande. Raccorder l'alimentation principale au module d'alimentation dans le tableau de commande sur une plaque à bornes avec relais. Le câblage et le remplacement d'un module d'alimentation doivent être effectués par un personnel de maintenance qualifié formé à la protection contre les chocs électriques.
Pour la méthode de câblage, se reporter au Manuel de l'utilisateur du module CPU MELSEC-L (Conception du matériel, maintenance et inspection).*

[Précautions de câblage]

ATTENTION

Précautions d'utilisation des modules compteurs haute-vitesse

- *Mettre le câble blindé à la masse du côté codage (boîte à relais). Toujours mettre à la masse les bornes FG et LG sur le conducteur de protection de terre. Le non-respect de cette précaution expose à des dysfonctionnements.*

Précautions d'utilisation du module maître CC-Lin/LT

- *Pour les CC-Link/LT, utiliser les câbles préconisés par la CC-Link Partner Association. L'utilisation de câbles autres que les câbles préconisés ne permet de garantir les performances du CC-Link/LT. Pour le câblage du réseau, suivre les prescriptions du Manuel de l'utilisateur Module maître MELSEC-L CC-Link/LT. La communication normale des données ne peut pas être garantie si ces prescriptions ne sont pas respectées.*

[Précautions de mise en service et de maintenance]

AVERTISSEMENT

- *Ne toucher à aucun des bornes quand le système est sous tension. Faute de quoi, il y a risque d'électrocutions et de dysfonctionnements.*
- *Raccorder correctement le connecteur des piles. Les piles ne doivent pas être rechargées, démontées, court-circuitées ou soudées. Elles ne doivent pas non plus être jetées au feu. De plus, ne pas exposer les piles à des liquides ou à des chocs violents. Les piles ainsi maltraitées risqueraient de surchauffer, d'éclater, de prendre feu ou de fuir et pourraient être à l'origine de blessures ou d'un départ de feu.*
- *Couper l'alimentation externe du système sur toutes les phases avant le nettoyage du module ou le resserrage des vis de borniers ou des vis de connecteurs. Faute de quoi, il y a risque d'électrocution.*

 **ATTENTION**

- *Avant d'effectuer une opération en ligne (en particulier une modification de programme, une sortie forcée ou un changement d'état fonctionnel) sur un module CPU actif d'une autre station à partie d'un périphérique connecté, consulter les manuels correspondants pour travailler en toute sécurité. Une fausse manœuvre pourrait être à l'origine d'un accident ou de dégâts matériels.*
- *Ne pas démonter ni modifier les modules. Cela pourrait entraîner des pannes ou dysfonctionnements et être à l'origine de blessures ou de départs de feu.*
- *Tout type d'appareil de communication radio, y compris les téléphones portables et les appareils PHS (Personal handy-phone system), doit être tenus éloignés de plus de 25cm de l'automate programmable, dans tous les sens. Le non-respect de cette précaution expose à des dysfonctionnements.*
- *Couper l'alimentation externe du système sur toutes les phases avant le nettoyage du module ou le resserrage des vis de borniers ou des vis de connecteurs. Le non-respect de cette précaution peut être à l'origine de pannes ou de dysfonctionnements du module.*
- *Serrer les vis des plaques à bornes et les vis des connecteurs dans les limites du couple de serrage prescrit. Un serrage insuffisant peut être à l'origine d'un détachement de pièces ou de fils et entraîner des dysfonctionnements. Un serrage excessif peut endommager les vis et/ou le module, avec aussi un risque de chute, de court-circuits et de dysfonctionnements.*
- *Après mise en service du module (y compris de l'afficheur), le nombre maximum admissible d'opérations de connexion/déconnexion du module est de 50. Le dépassement de cette limitation (selon norme IEC 61131-2) peut être à l'origine de dysfonctionnements.*
- *Après mise en service du produit, le nombre maximum admissible d'opérations d'insertion/retrait de la carte-mémoire SD est de 50. Le dépassement de cette limite peut être à l'origine de dysfonctionnements.*

[Précautions de mise en service et de maintenance]

ATTENTION

- *Ne pas faire tomber ou soumettre à de forts chocs les piles à installer dans les modules. Cela pourrait endommager les piles, avec risque de fuite du liquide à l'intérieur des piles. Toute pile qu'on a laissé tomber ou qui a subi un choc violent doit être jetée avant usage.*
- *Avant de manipuler un module, se débarrasser de la charge électrostatique qu'accumule le corps humain en touchant un objet conducteur approprié. Le non-respect de cette précaution peut être à l'origine de pannes ou de dysfonctionnements du module.*
- *Avant de procéder aux essais de la fonction de positionnement du module CPU, régler le paramètre de limite de vitesse sur une petite valeur de vitesse pour pouvoir interrompre immédiatement la marche en cas de danger.*

Précautions d'utilisation des modules de positionnement

- *Avant les essais de marche, régler le paramètre de limite de vitesse sur une petite valeur de vitesse pour pouvoir interrompre immédiatement la marche en cas de danger.*

Précautions pour l'utilisation des module de commande E/S flexibles haute vitesse

- *Avant d'effectuer toute opération en ligne sur le module en marche à partir d'un ordinateur individuel, lisez attentivement les manuels correspondants pour pouvoir garantir la sécurité.*
- *Avant de changer le paramétrage du module, lisez attentivement les manuels correspondants pour pouvoir garantir la sécurité, et faites passer le module CPU à l'état STOP.*

[Précautions d'exploitation]

ATTENTION

- *Pour intervenir sur un automate programmable en marche (en particulier pour un changement de données, une modification de programme ou un changement d'état opérationnel) à partir d'un dispositif externe raccordé à un module fonctionnel intelligent, lire attentivement le manuel de l'utilisateur avant l'intervention pour pouvoir garantir la sécurité. Tout changement incorrect dans les données, dans le programme ou dans les états fonctionnels peut entraîner des dysfonctionnements du système et être à l'origine de dégâts matériels ou d'un accident.*
- *Pendant que les valeurs de consigne de la mémoire-tampon sont en cours d'enregistrement dans la ROM-flash du module, ne pas couper l'alimentation du module et ne pas réinitialiser le module CPU. Cela pourrait affecter les données en ROM-flash et il serait nécessaire de refaire les réglages et de reprendre l'enregistrement de la mémoire-tampon en ROM-flash. De plus cela pourrait être à l'origine d'une panne du module, ou de dysfonctionnements.*

[Précautions de mise au rebut]

ATTENTION

- *Lors de sa mise au rebut, ce produit doit être traité comme un déchet industriel. Les piles ou batteries doivent être mises au rebut séparément des autres déchets et conformément à la réglementation locale. Pour le détail des directives sur les piles et batteries dans les pays de l'Union Européenne, voir le Manuel de l'utilisateur du module CPU pour MELSEC-L (Conception du matériel, maintenance et inspection).*

[Précautions de transport]

ATTENTION

- *Pour le transport des piles au lithium, respecter la réglementation afférente à ce transport. (Pour le détail des modèles soumis à la réglementation, voir le Manuel de l'utilisateur du module CPU pour MELSEC-L (Conception du matériel, maintenance et inspection)).*

● CONDITIONS OF USE FOR THE PRODUCT ●

- (1) Mitsubishi programmable controller ("the PRODUCT") shall be used in conditions;
- i) where any problem, fault or failure occurring in the PRODUCT, if any, shall not lead to any major or serious accident; and
 - ii) where the backup and fail-safe function are systematically or automatically provided outside of the PRODUCT for the case of any problem, fault or failure occurring in the PRODUCT.
- (2) The PRODUCT has been designed and manufactured for the purpose of being used in general industries.
- MITSUBISHI SHALL HAVE NO RESPONSIBILITY OR LIABILITY (INCLUDING, BUT NOT LIMITED TO ANY AND ALL RESPONSIBILITY OR LIABILITY BASED ON CONTRACT, WARRANTY, TORT, PRODUCT LIABILITY) FOR ANY INJURY OR DEATH TO PERSONS OR LOSS OR DAMAGE TO PROPERTY CAUSED BY the PRODUCT THAT ARE OPERATED OR USED IN APPLICATION NOT INTENDED OR EXCLUDED BY INSTRUCTIONS, PRECAUTIONS, OR WARNING CONTAINED IN MITSUBISHI'S USER, INSTRUCTION AND/OR SAFETY MANUALS, TECHNICAL BULLETINS AND GUIDELINES FOR the PRODUCT.
- ("Prohibited Application")
- Prohibited Applications include, but not limited to, the use of the PRODUCT in;
- Nuclear Power Plants and any other power plants operated by Power companies, and/or any other cases in which the public could be affected if any problem or fault occurs in the PRODUCT.
 - Railway companies or Public service purposes, and/or any other cases in which establishment of a special quality assurance system is required by the Purchaser or End User.
 - Aircraft or Aerospace, Medical applications, Train equipment, transport equipment such as Elevator and Escalator, Incineration and Fuel devices, Vehicles, Manned transportation, Equipment for Recreation and Amusement, and Safety devices, handling of Nuclear or Hazardous Materials or Chemicals, Mining and Drilling, and/or other applications where there is a significant risk of injury to the public or property.

Notwithstanding the above, restrictions Mitsubishi may in its sole discretion, authorize use of the PRODUCT in one or more of the Prohibited Applications, provided that the usage of the PRODUCT is limited only for the specific applications agreed to by Mitsubishi and provided further that no special quality assurance or fail-safe, redundant or other safety features which exceed the general specifications of the PRODUCTS are required. For details, please contact the Mitsubishi representative in your region.

CONTENTS

1. CHECKING THE INCLUDED ITEMS	1
2. GENERAL SPECIFICATIONS	4
3. MOUNTING THE MODULES	6
3.1 Precautions for Connecting and Mounting Modules	6
3.2 Connecting Modules	8
3.3 Mounting the Modules on a DIN Rail	10
4. EMC AND LOW VOLTAGE DIRECTIVES	13
4.1 Measures to Comply with the EMC Directive	14
4.2 Measures to Comply with the Low Voltage Directive	28
5. GENERAL SAFETY REQUIREMENTS	32
6. SIGNAL LAYOUT OF THE CONNECTOR FOR EXTERNAL DEVICE CONNECTION	37

RELATED MANUALS

The following manuals are related to this product.
Order each manual as needed, referring to the following list.

Detailed manuals

Manual name	Manual Number (Model code)
MELSEC-L CPU Module User's Manual (Hardware Design, Maintenance and Inspection) Explains the specifications, system configuration, maintenance, and troubleshooting of the CPU module, power supply module, display unit, branch module, extension module, SD memory card, and batteries. (Sold separately.)	SH-080890ENG (13JZ36)
MELSEC-L CPU Module User's Manual (Function Explanation, Program Fundamentals) Explains the functions, programming, and devices of the CPU module. (Sold separately.)	SH-080889ENG (13JZ35)

1. CHECKING THE INCLUDED ITEMS

The following items are included in the package of this product. Before use, check that all the items are included.

(1) L02SCPU, L02SCPU-P

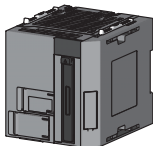

CPU module + END cover (L6EC)
(A dummy cover for the display unit is attached.)



This manual



Battery (Q6BAT)
(Installed in the CPU module.)



Battery replacement date
stickers to fill out
(Three stickers on one sheet)

(2) L02CPU, L02CPU-P, L06CPU, L06CPU-P, L26CPU, L26CPU-P

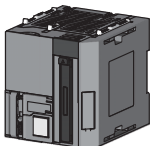

CPU module + END cover (L6EC)
(A dummy cover for the display unit is attached.)



This manual



Battery (Q6BAT)
(Installed in the CPU module.)



Battery replacement date
stickers to fill out
(Three stickers on one sheet)

(3) L02CPU-SET, L02CPU-P-SET, L06CPU-SET, L06CPU-P-SET,
L26CPU-SET, L26CPU-P-SET

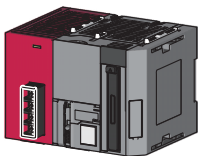

Power supply module (L61P)
+ CPU module
+ END cover (L6EC)
(A dummy cover for the display unit
is attached.)

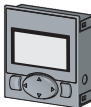

Display unit
(L6DSPU)



This manual + Included
materials (for display unit
and power supply module)



Battery (Q6BAT)
(Installed in the CPU module.)



Battery replacement date
stickers to fill out
(Three stickers on one
sheet)

(4) L26CPU-BT, L26CPU-PBT

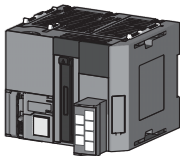

CPU module + END cover (L6EC)
(A dummy cover for the display unit is attached.)



This manual



Battery (Q6BAT)
(Installed in the CPU
module.)



A set of terminating resistors
• Terminating resistor 110Ω 1/2W×2 pieces
(Brown-Brown-Brown, gold)
• "CAUTION" note



Battery replacement
date stickers to fill out
(Three stickers on one
sheet)

(5) L26CPU-BT-SET, L26CPU-PBT-SET

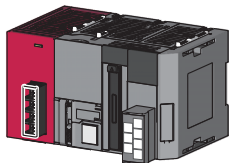

Power supply module (L61P)
+ CPU module
+ END cover (L6EC)
(A dummy cover for the display unit is
attached.)

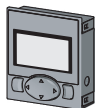

Display unit
(L6DSPU)



This manual + Included
materials (for display unit
and power supply
module)



Battery (Q6BAT)
(Installed in the CPU module.)



A set of terminating
resistors

- Terminating resistor
110Ω 1/2W×2 pieces
(Brown-Brown-Brown,
gold)
- "CAUTION" note



Battery replacement date
stickers to fill out
(Three stickers on one
sheet)

2. GENERAL SPECIFICATIONS

This section provides specifications common to the relevant modules.

Item	Specifications					
Operating ambient temperature <i>Température ambiante de fonctionnement</i>	0 to 55°C 0 à 55 °C					
Storage ambient temperature	-25 to 75°C					
Operating ambient humidity	5 to 95%RH, non-condensing					
Storage ambient humidity						
Vibration resistance	Compliant with JIS B 3502 and IEC 61131-2	Under intermittent vibration	Frequency	Constant acceleration	Half amplitude	Sweep count
			5 to 8.4Hz	—	3.5mm	10 times each in X, Y, and Z directions
		Under continuous vibration	8.4 to 150Hz	9.8m/s ²	—	
			5 to 8.4Hz	—	1.75mm	—
8.4 to 150Hz	4.9m/s ²	—				
Shock resistance	Compliant with JIS B 3502 and IEC 61131-2 (147m/s ² , 3 times each in 3 directions X, Y, Z)					
Operating atmosphere	No corrosive gases					
Operating altitude ^{*1}	0 to 2000m					
Installation location	Inside a control panel					
Overvoltage category ^{*2}	II or less					
Pollution degree ^{*3}	2 or less					
Equipment category	Class I					

*1 Do not use or store the programmable controller under pressure higher than the atmospheric pressure of altitude 0m. Doing so may cause malfunction. When using the programmable controller under pressure, please consult your local Mitsubishi Electric representative.

- *2 This indicates the section of the power supply to which the equipment is assumed to be connected between the public electrical power distribution network and the machinery within premises. Category II applies to equipment for which electrical power is supplied from fixed facilities. The surge voltage withstand level for up to the rated voltage of 300V is 2500V.
- *3 This index indicates the degree to which conductive material is generated in terms of the environment in which the equipment is used. Pollution level 2 is when only non-conductive pollution occurs. A temporary conductivity caused by condensing must be expected occasionally.

POINT

For the product to comply with the EMC or Low Voltage Directive, refer to



Chapter 4

3. MOUNTING THE MODULES

This section explains how to interconnect modules and how to mount them on a DIN rail. The following illustration is an example of the interconnection.

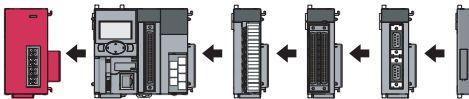

POINT

- (1) Modules must be mounted on a DIN rail.
- (2) Connect an END cover on the right of the terminal module.
- (3) For installation environment and mounting position of the modules, refer to the following.



MELSEC-L CPU Module User's Manual
(Hardware Design, Maintenance and Inspection)

3.1 Precautions for Connecting and Mounting Modules

- Do not directly touch any conductive parts and electronic components of the module. Doing so can cause malfunction or failure of the module.
- After the first use of the module (including a display unit), the number of connections/disconnections is limited to 50 times. Exceeding the limit (in accordance with IEC 61131-2) may cause malfunction.
- Do not drop or apply strong shock to the module case or terminal block connector.
- Do not remove a printed-circuit board of the module from the case. Doing so may cause failure of the module and/or printed-circuit board.
- When installing the programmable controller in a control panel, fully consider its operability, maintainability, and environmental resistance. Securely fix all the MELSEC-L series modules used with the DIN rail. For details on the mounting method, refer to the MELSEC-L CPU Module User's Manual (Hardware Design, Maintenance and Inspection).

- *Pour installer l'automate programmable dans un tableau de commande, prendre en compte tous les aspects d'opérabilité, de maintenabilité et de résistance à l'environnement. Fixer fermement sur un rail DIN tous les modules de la série MELSEC-L à utiliser. Pour le détail de l'installation, voir aussi le Manuel de l'utilisateur MELSEC-L CPU module (conception du matériel, maintenance et inspection).*

3.2 Connecting Modules

This section explains the procedure for connecting modules with an example of how to connect the L02CPU with the L61P.

Shut off the external power supply for the system in all phases before connecting modules.

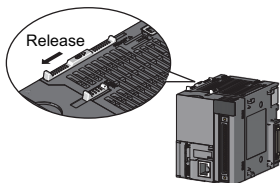

1. To release the module joint levers located at the top and bottom of the L02CPU:

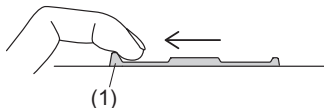

2. Slide the levers toward the front side of the module until they click. To release the levers, pull the projection (1) of the lever.

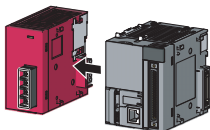

3. Insert the connector of the power supply module into that of the CPU module so that they are securely engaged.

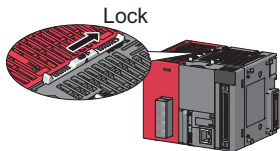

4. To lock the module joint levers:

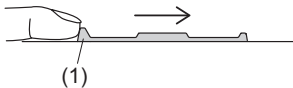

- Slide the levers toward the back side of the module until they click. Make sure that the modules are securely connected. To lock the levers, push the projection (1) of the lever.

POINT

- Failure to securely lock the module joint levers until they click may cause malfunction, failure, or drop of the module.
- To slide the levers, use the projection of the lever. Sliding levers with other parts than the projection may cause a difficulty of sliding.

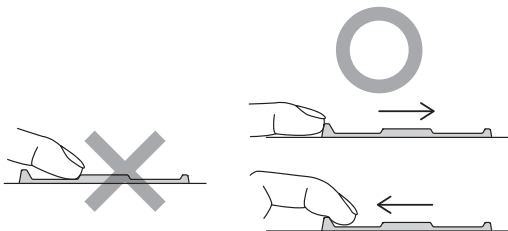

- The metal parts of a module (such as the back side) may be heated to a high temperature immediately after the power is turned off. Therefore, be careful not to burn yourself when disconnecting a module.

3.3 Mounting the Modules on a DIN Rail

This section explains the procedure for mounting the modules on a DIN rail.

POINT

An example of the use of the DIN rail stopper is described in the following procedure. Fix the module according to the manual of the DIN rail stopper used.

(1) Mounting procedure

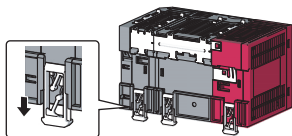

1. Pull down DIN rail hooks on the back of the modules until they click.

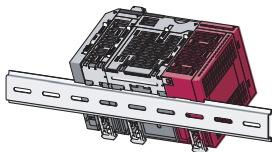

2. Hang the upper tabs of the modules on a DIN rail, and push the modules in position.

Applicable DIN rail model name

- (IEC 60715)
- TH35-7.5Fe
 - TH35-7.5Al
 - TH35-15Fe

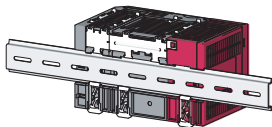

3. Lock the DIN rail hooks to the DIN rail to secure the modules in the position.

Pull the hooks up until they click.

If the hooks are beyond the reach, use a tool such as a driver.

(To the next page)

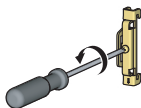

4. Loosen the screw on DIN rail stopper.
(Use a stopper that is attachable to the DIN rail.)

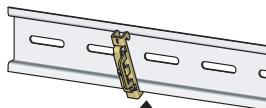

Hitch the hook to
bottom of the DIN rail

5. Hitch the bottom hook of the DIN rail stopper to the bottom of the DIN rail.
Check the orientation of the DIN rail stopper according to the arrow on the front of the stopper.

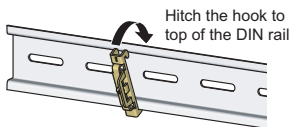

Hitch the hook to
top of the DIN rail

6. Hitch the upper hook of the DIN rail stopper to the top of the DIN rail.

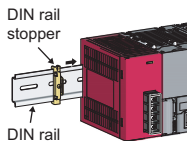

7. Slide the DIN rail stopper to the leftmost module.

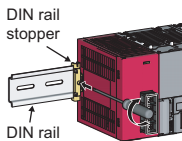

8. Hold the DIN rail stopper in the direction opposite to the arrow on the stopper and tighten the screw with a driver.

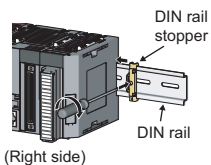

9. Attach a DIN rail stopper on the right of the module with the same procedure. Install the stopper upside down for the right side.

POINT

Do not slide modules from the edge of the DIN rail when mounting. Doing so may damage the metal part located on the back of the module.

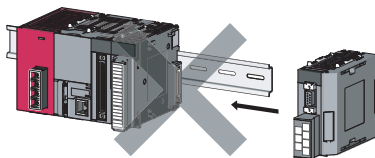

4. EMC AND LOW VOLTAGE DIRECTIVES

Compliance to the EMC Directive, which is one of the EU Directives, has been a legal obligation for the products sold in European countries since 1996 as well as the Low Voltage Directive since 1997.

Manufacturers who recognize their products are compliant to the EMC and Low Voltage Directives are required to attach a "CE mark" on their products.

(1) Sales representative in EU member states

Authorized representative in Europe is shown below.

Name: Mitsubishi Electric Europe BV

Address: Gothaer Strasse 8, 40880 Ratingen, Germany

4.1 Measures to Comply with the EMC Directive

The EMC Directive specifies that "products placed on the market must be so constructed that they do not cause excessive electromagnetic interference (emissions) and are not unduly affected by electromagnetic interference (immunity)". This section summarizes the precautions on compliance with the EMC Directive of the machinery constructed with the MELSEC-L series modules.

These precautions are based on the requirements and the standards of the regulation, however, it does not guarantee that the entire machinery constructed according to the descriptions will comply with above-mentioned directives.

The method and judgement for complying with the EMC Directive must be determined by the person who constructs the entire machinery.

(1) EMC Directive related standards

(a) Emission requirements

Specification	Test item	Test details	Standard value
EN61131-2: 2007	CISPR16-2-3 Radiated emission*2	Radio waves from the product are measured.	<ul style="list-style-type: none">• 30M-230MHz QP: 40dBμV/m (10m in measurement range)*1• 230M-1000MHz QP: 47dBμV/m (10m in measurement range)
	CISPR16-2-1, CISPR16-1-2 Conducted emission*2	Noise from the product to the power line is measured.	<ul style="list-style-type: none">• 150k-500kHz QP: 79dB, Mean: 66dB*1• 500k-30MHz QP: 73dB, Mean: 60dB

*1 QP: Quasi-peak value, Mean: Average value

*2 Programmable controller is an open type device (a device designed to be housed in other equipment) and must be installed inside a conductive control panel. The tests were conducted with the programmable controller installed in a control panel, applying the maximum applicable input voltage to the power supply module.

(b) Immunity requirements

Specification	Test item	Test details	Standard value
EN61131-2: 2007	EN61000-4-2 Electrostatic discharge immunity* ¹	Immunity test in which electrostatic is applied to the cabinet of the equipment.	<ul style="list-style-type: none"> • 8kV Air discharge • 4kV Contact discharge
	EN61000-4-3 Radiated, radio-frequency, electromagnetic field immunity* ¹	Immunity test in which electric fields are irradiated to the product.	80% AM modulation@1kHz <ul style="list-style-type: none"> • 80M-1000MHz: 10V/m • 1.4G-2.0GHz: 3V/m • 2.0G-2.7GHz: 1V/m
	EN61000-4-4 Electrical fast transient/burst immunity* ¹	Immunity test in which burst noise is applied to the power line and signal line.	<ul style="list-style-type: none"> • AC/DC main power, I/O power, AC I/O (unshielded): 2kV • DC I/O, analog, communication : 1kV
	EN61000-4-5 Surge immunity* ¹	Immunity test in which lightning surge is applied to the power line and signal line.	<ul style="list-style-type: none"> • AC power line, AC I/O power, AC I/O (unshielded) : 2kV CM, 1kV DM • DC power line, DC I/O power : 0.5kV CM, DM • DC I/O, AC I/O (shielded), analog*², communication: 1kV CM
	EN61000-4-6 Immunity to conducted disturbances, induced by radio-frequency fields* ¹	Immunity test in which high frequency noise is applied to the power line and signal line	0.15M-80MHz, 80% AM modulation @1kHz, 10Vrms
	EN61000-4-8 Power-frequency magnetic field immunity* ¹	Immunity test in which the product is installed in inductive magnetic field	50Hz/60Hz, 30A/m
	EN61000-4-11 Voltage dips and interruption immunity* ¹	Immunity test in which power supply voltage is momentarily interrupted	<ul style="list-style-type: none"> • Apply at 0%, 0.5 cycles and zero-cross point • 0%, 250/300 cycles (50/60Hz) • 40%, 10/12 cycles (50/60Hz) • 70%, 25/30 cycles (50/60Hz)

*1 Programmable controller is an open type device (a device designed to be housed in other equipment) and must be installed inside a conductive control panel. The tests were conducted with the programmable controller installed in a control panel.

*2 The accuracy of an analog-digital converter module may temporary vary within $\pm 10\%$.

(2) Installation in a control panel

The programmable controllers are open type devices and must be installed inside a control panel.*¹

This ensures safety as well as effective shielding of programmable controller-generated electromagnetic noise.

*¹ Modules on the remote station in each network must be also installed inside the control panel. However, the waterproof type remote station can be installed outside the control panel.

(a) Control panel

- Use a conductive control panel.
- When securing the top or bottom plate using bolts, cover the grounding part on the control panel so that the part will not be painted.
- To ensure electrical contact between the inner plate and control panel, take measures such as covering the bolts so that conductivity can be ensured in the largest possible area.
- Ground the control panel with a thick ground cable so that low impedance can be ensured even at high frequencies.
- Holes in the control panel must be 10cm diameter or less. If the holes are larger than 10cm, radio wave may be emitted. In addition, because radio waves leak through a clearance between the control panel and its door, reduce the clearance as much as possible. The leakage of radio waves can be suppressed by the direct application of an EMI gasket on the paint surface.

Our tests have been carried out on a panel having the attenuation characteristics of 37 dB (max.) and 30 dB (mean) (measured by 3m method, 30 to 300MHz).

(b) Wiring power cables

- Provide a ground point near the power supply module. Ground the LG and FG terminals of the power supply module with the thickest and shortest ground cable (30cm or shorter) possible.

(3) Cables

Use shielded cables for the cables which are connected to the I/O modules and may be extended out of the control panel.

If a shielded cable is not used or not grounded correctly, the noise immunity will not meet the specified value.

(a) Grounding a shielded cable

- Ground the shield of the shielded cable as close to the module as possible so that the grounded cable will not be affected by electromagnetic induction from ungrounded cables.
- Ground the exposed shield section to large area on the control panel. A clamp fitting can be used as shown in below. In this case, mask off inner wall surface of the control panel, which comes in contact with the clamp.

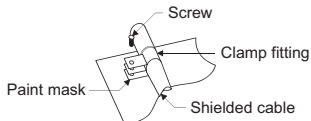

POINT

Grounding with a vinyl-coated wire soldered onto the shielded section of the shielded cable as shown below is not recommended. Doing so will raise the high-frequency impedance, resulting in loss of the shielding effect.

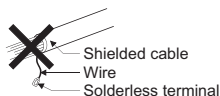

(b) Grounding a twisted pair cable

- Always use shielded twisted pair cables for connection to 10BASE-T and 100BASE-TX connectors.

For the shielded twisted pair cable, strip a part of the jacket as shown below and ground the exposed shield section to the ground as much as possible.

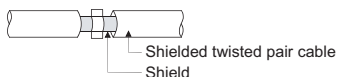

- (c) Grounding a Ver.1.10-compatible CC-Link dedicated cable
- Be sure to ground the cable shield that is connected to the CC-Link module close to the exit of control panel or to any of the CC-Link stations within 30cm from the module or stations. The CC-Link Ver. 1.10 compatible cable is a shielded cable. Strip a part of the jacket as shown below and ground the exposed shield section to the ground as much as possible.



Always use the specified CC-Link Ver. 1.10 compatible cable. Connect the CC-Link module and the CC-Link stations to the FG line inside the control panel at the FG terminal as shown below.

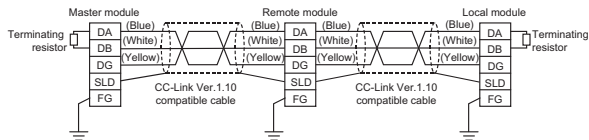

- (d) Grounding cables with a cable clamp
Use shielded cables for external wiring and ground the shields of the external wiring cables to the control panel with the AD75CK-type cable clamping (Mitsubishi). (Ground the shield section 20 to 30cm away from the module.)

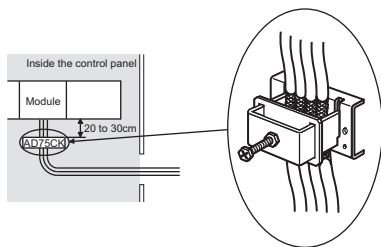

For details of the AD75CK, refer to the following.



AD75CK-type Cable Clamping Instruction Manual

(e) Connectors for external devices

When using connectors for external devices with any of the following modules, take the noise reduction measures described below.

- CPU module
- High-speed counter module
- Positioning module
- Flexible high-speed I/O control module

[Wiring example when using shielded cables]

The following figure shows the example of wiring using A6CON1 for noise reduction.

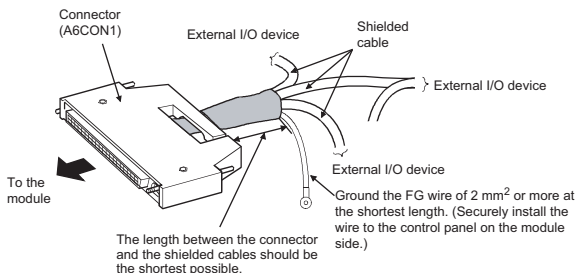

[Example of processing for a shielded cable]

To protect signals, cover connector pins with heat shrinkable insulation tube. (If signals are stripped, they are affected by static electricity and may result in malfunction.)

Take off the insulating tube of each shield and connect the shields of the cables with conductive tapes.

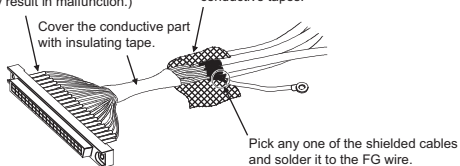

[Wiring example when using a duct (problematic example and modification example)]

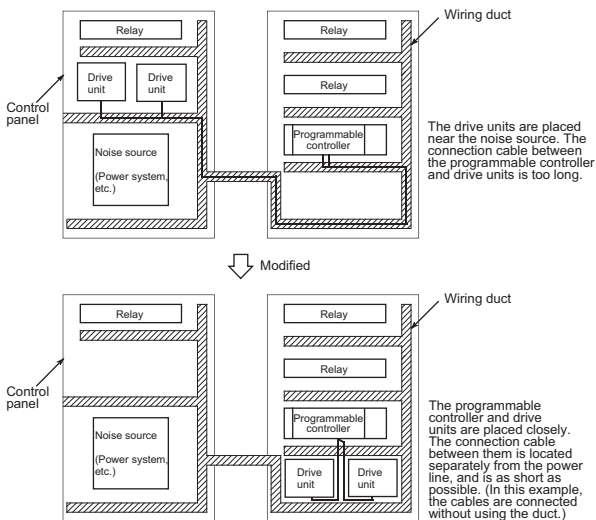

(f) CC-Link IE Field Network module

The precautions for using CC-Link IE Field Network cables are described below.

- For CC-Link IE Field Network module, use CC-Link IE Field Network cables (SC-E5EW-S□M, manufactured by Mitsubishi Electric System & Service Co., Ltd.).
- A CC-Link IE Field Network cable is a shielded cable. Remove a part of the shield as shown below and ground the largest possible exposed section to the ground.

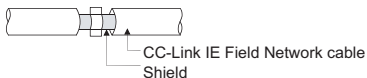

To ground the cables for external wiring, refer to Section 4.1 (3) (d)

- (g) I/O signal cables and other communication cables
For the following cables, if pulled out of the control panel, always ground the shield section of these lines and cables in the same manner described in (a).
- I/O signal lines (including a common line)
 - RS-232 cable
- (h) Extension cable
For an extension cable, always ground the exposed section of the shielded cable as in (a) if it is pulled out of the control panel.
- (i) Power cables for external power supply terminal
As an external power supply for the following modules, use a CE-marked AC/DC power supply with a reinforced insulation or a double insulation. Install the AC/DC power supply in the control panel where the module is installed. Keep the length of the power cable connected to the external power supply terminal to 30m or less.
- Analog-digital converter module
 - Digital-analog converter module
 - Analog input/output module
 - High-speed counter module
 - Positioning module
 - Temperature control module
 - Flexible high-speed I/O control module
- (4) External power supply
Use a CE-marked external power supply with a reinforced insulation or a double insulation and ground the FG terminals.
(External power supply used for the tests conducted by Mitsubishi: TDK-Lambda DLP-120-24-1, IDEC PS5RSF24)
- (5) Power supply module
- Always ground the LG and FG terminals after shunting them.
 - Use a CE-marked external power supply with a reinforced insulation or a double insulation to supply 24VDC to the L63SP.
- (6) SD memory card
The SD memory cards manufactured by Mitsubishi (NZ1MEM-□GBSD and L1MEM-□GBSD) conform to IEC 61131-2 when being used in the MELSEC-L series CPU module.

- (7) CPU module (Positioning function)
To use the positioning function, the length of the cable to be connected to external devices must be as shown below.
- Positioning pulse output: 2m or less
 - General-purpose output: 30m or less
- (8) I/O modules
- Install the DC power in the same control panel with the modules.
 - When a cable for the DC power is installed extending outside the control panel, use a shielded cable.
 - A cable for the DC power must be 30m or less in length.
 - When the number of relay operations is more than 4 times per minute, take measures such as using a surge suppressor.
- (9) High-speed counter module
- Install the DC power in the same control panel with the modules.
 - When a cable for the DC power is installed extending outside the control panel, use a shielded cable.
 - Keep the length of cables connected to external devices to 30m or less.
- (10) Positioning module
Install the DC power in the same control panel with the modules.
- (11) Temperature control module
Install the DC power in the same control panel with the modules.
- (12) Flexible high-speed I/O control module
Take following measures.
- Attach a ferrite core to the cable for the DC power connected to the flexible high-speed I/O control module, and to the cable for the DC power connected to a controller. For a ferrite core, the ESD-SR-250 (manufactured by NEC TOKIN Corporation) is recommended.
 - Install the DC power in the same control panel where the module is installed.
 - Use a shielded cable when a DC power cable is laid out of the control panel.
 - The length of the cable connected to an output part or external devices must be 2m or less for open collector output, and 10m or less for differential output.
 - The length of the cable connecting an input part and external devices must be 30m or less.

(13) CC-Link module

- To ground the Ver.1.10-compatible CC-Link dedicated cable, (3)(c) in this section.
- Each power line connecting to the external power supply terminal or module power supply terminal must be 30m or less.
- Install a noise filter to the external power supply. Use the noise filter having an attenuation characteristic, MA1206 (TDK-Lambda) or equivalent. Note that a noise filter is not required if the module is used in Zone A defined in EN61131-2.
- Keep the length of signal cables connected to the analog input terminals of the following modules to 30m or less.
- Wire cables connected to the external power supply and module power supply terminal in the control panel where the module is installed.
 - AJ65BT-64RD3
 - AJ65BT-64RD4
 - AJ65BT-68TD
- For the cable connected to the power supply terminal of the AJ65SBT-RPS, AJ65SBT-RPG or AJ65BT-68TD, attach a ferrite core with attenuation characteristic equivalent to that of the ZCAT3035-1330 from TDK Corporation. Twist the cable around the ferrite core by one as shown below.

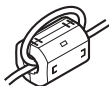

- To supply the module power supply terminal of the AJ65BTB2-16R/16DR, AJ65SBTB2N-8A/8R/8S/16A/16R/16S with power using the AC/DC power supply, follow as shown below.
 - Install the AC/DC power supply in the control panel where the module is installed.
 - Use a CE-marked AC/DC power supply with a reinforced insulation or a double insulation and ground the FG terminals. (The AC/DC power supply used for the tests conducted by Mitsubishi: TDK-Lambda Corporation: DLP-120-24-1)
 - For the cable connected to the AC input terminal and DC output terminals of the AC/DC power supply, attach a ferrite core. Twist the cable around the ferrite core by one as shown below. (Ferrite core used for the tests conducted by Mitsubishi: NEC TOKIN Corporation: ESD-SR-250)

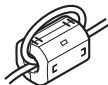

(14) CC-Link/LT module

- Use the module under the installation environment of Zone A^{*1}. For the specified Zones of the following products, refer to the manual provided with each product:
 - CL1Y4-R1B1 • CL1Y4-R1B2 • CL1XY4-DR1B2
 - CL1XY8-DR1B2 • CL1PSU-2A
- To supply the CL2DA2-B and CL2AD4-B with power using the CL1PAD1, keep the length of the power cable connected from the CL1PAD1 to the external power supply to 30m or less.

*1 Zone defines categories according to industrial environment, specified in the EMC and Low Voltage Directives, EN61131-2.

Zone C: Factory mains (isolated from public mains by dedicated transformer)

Zone B: Dedicated power distribution, secondary surge protection (rated voltage: 300V or less)

Zone A: Local power distribution, protected from dedicated power distribution by AC/DC converter and insulation transformer (rated voltage: 120V or less)

(15) Other measures

(a) Ferrite core

Ferrite core is effective for reducing radiated noise in the 30MHz to 100MHz frequency band.

It is recommended to install a ferrite core if a shield cable extended out of the control panel does not provide sufficient shielding effects.

Install a ferrite core to the cable in the position immediately before the cable is extended out of the control panel. If the installation position is not appropriate, the ferrite core will not produce any effect.

Install a ferrite core to each power cable as shown below.

(Ferrite core used for the tests conducted by Mitsubishi: NEC TOKIN ESD-SR-250)

Example

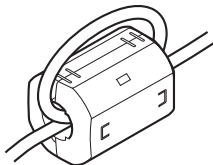

(b) Noise filter (power supply line filter)

A noise filter is a component which has an effect on conducted noise.

Attaching the filter can suppress more noise. (The noise filter has the effect of reducing conducted noise of 10 MHz or less.)

The precautions for attaching a noise filter are described below.

- Do not bundle the cables on the input side and output side of the noise filter. If bundled, the output side noise will be induced into the input side cables from which the noise was filtered.

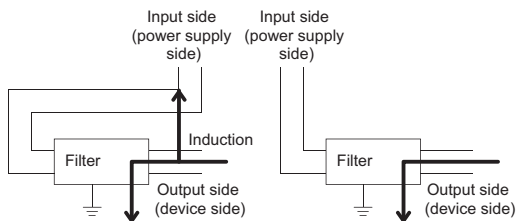

Noise will be induced when the input and output wires are bundled.

Separately install the input and output wires.

- Ground the noise filter grounding terminal to the control panel with the shortest cable possible (approx. 10cm).

(c) Insulation transformer

An isolation transformer has an effect on reducing conducted noise (especially, lightning surge).

Lightning surge may cause a malfunction of the programmable controller.

As measures against lightning surge noise, connect an isolation transformer as shown below.

Using an isolation transformer will reduce an impact of lightning.

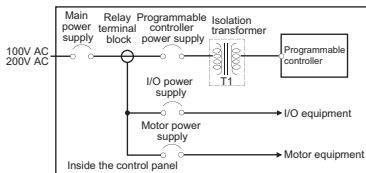

4.2 Measures to Comply with the Low Voltage Directive

The Low Voltage Directive requires each device that operates with the power supply ranging from 50 to 1000VAC and 75 to 1500VDC to satisfy the safety requirements.

This section summarizes precautions on using the MELSEC-L series modules to comply with the Low Voltage Directive. These descriptions are based on the requirements and standards of the regulation; however, it does not guarantee that the entire machinery manufactured based on the descriptions complies with the Low Voltage Directive. The method and judgment for the Low Voltage Directive must be left at manufacturer's own discretion.

(1) Standard applied to MELSEC-L series modules

- EN61010-1 Safety of equipment used in measurements, controls, or laboratories.

The MELSEC-L series modules with a rated voltage of 50VAC and 75VDC or higher have been also developed to conform to the above standard.

The modules which operate at the rated voltage of less than 50VAC and 75VDC are out of the Low Voltage Directive application range.

- (2) Precautions when selecting MELSEC-L series products
- (a) Power supply module
There are dangerous voltages (voltages higher than or equal to 42.4V peak) inside the power supply modules of 100VAC and 200VAC rated input voltages. Therefore, for CE-marked products, insulation is reinforced internally between the primary and secondary circuits.
- (b) I/O modules
There are dangerous voltages (voltages higher than or equal to 42.4V peak) in the I/O modules of 100VAC and 200VAC rated I/O voltages. Therefore, for CE-marked products, insulation is reinforced internally between the primary and secondary circuits.
The I/O modules of 24VDC or less rating are out of the Low Voltage Directive application range.
- (c) GOT
Use a CE-marked product.
- (d) Products not subject to the Low Voltage Directive
Using 5VDC circuit inside, the following modules are out of the Low Voltage Directive application range.
- CPU module (including built-in I/O part)
 - SD memory card
 - Display unit
 - RS-232 adapter
 - END cover
- The intelligent function modules are out of the scope of the Low Voltage Directive because the rated voltage is 24VDC or less.
- (3) Power supply
The insulation specification of the power supply module was designed assuming Installation Category II. Satisfy the Installation Category II for the power supply to the programmable controller.

(4) Control panel

(a) Protection against electric shock

The control panel must be handled as shown below to protect a person who does not have adequate knowledge of electricity from an electric shock.

- Lock the control panel so that only those who are trained and have acquired enough knowledge of electric facilities can open the control panel.
- The control panel must have a structure that automatically stops the power supply when the control panel is opened.
- Use the control panel whose protection degree is IP20 or higher for the purpose of electric shock protection.

(b) Protection from dust and water

The control panel also has the dustproof and waterproof functions. Insufficient dustproof and waterproof features lower the dielectric withstand voltage, resulting in insulation destruction.

The insulation in our programmable controllers are designed to cope with the pollution level 2, so use it in an environment with pollution level 2 or below.

The pollution level 2 environments can be achieved when the programmable controller is stored in a control panel equivalent to IP54.

(5) External wiring

(a) 24VDC external power supply

For the 24VDC I/O modules and intelligent function modules requiring an external power supply, use a 24VDC-circuit whose insulation is reinforced from the hazardous voltage circuit.

(b) External devices

When a device with hazardous voltage circuit is externally connected to the programmable controller, use a device whose circuit section of the interface to the programmable controller is intensively insulated from the hazardous voltage circuit.

(c) Reinforced insulation

The reinforced insulation covers the withstand voltages shown below.

Rated voltage of hazardous voltage area	Surge withstand voltage (1.2/50 μ s)
150VAC or lower	2500V
300VAC or lower	4000V

(Installation Category II, source: IEC 664)

5. GENERAL SAFETY REQUIREMENTS

When a programmable controller is powered on or off, proper output of the control target may not function temporarily due to delay and startup time differences between the power supply for the programmable controller and the external power supply for the control target (especially in the case of DC). Also, an abnormal operation may occur if an external power supply or the programmable controller fails.

From the point of view of fail-safe circuit and to prevent any of these abnormal operations from leading to the entire system failure, configure external fail-safe circuits (an emergency stop circuit, protection circuit, and interlock circuit) in the areas where incorrect operation can result in mechanical damage or accidents.

This chapter shows a circuit example of system designs.

(1) System design circuit example

(a) When not using END cover with ERR terminal

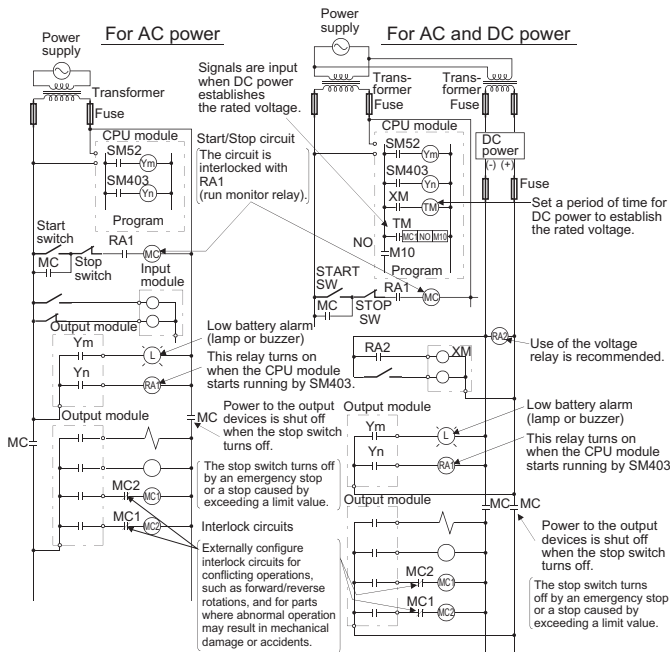

The power-on procedure is as follows:

- For AC power

- 1) Power on the programmable controller.
- 2) Set the CPU module to RUN.
- 3) Turn on the start switch.
- 4) When the electromagnetic contactor (MC) turns on, the output devices will be activated by the program.

- For AC and DC power

- 1) Power on the programmable controller.
- 2) Set the CPU module to RUN.
- 3) RA2 turns on when DC power is on.
- 4) Timer (TM) turns on when DC power establishes the rated voltage.
(The timer value is the period of time from when RA2 turns on to when DC power establishes the rated voltage. Set this value to 0.5 seconds.)
- 5) Turn on the start switch.
- 6) When the electromagnetic contactor (MC) turns on, the output devices will be activated by the program.
(If a voltage relay is used at RA2, no timer (TM) is required in the program.)

(b) When using END cover with ERR terminal

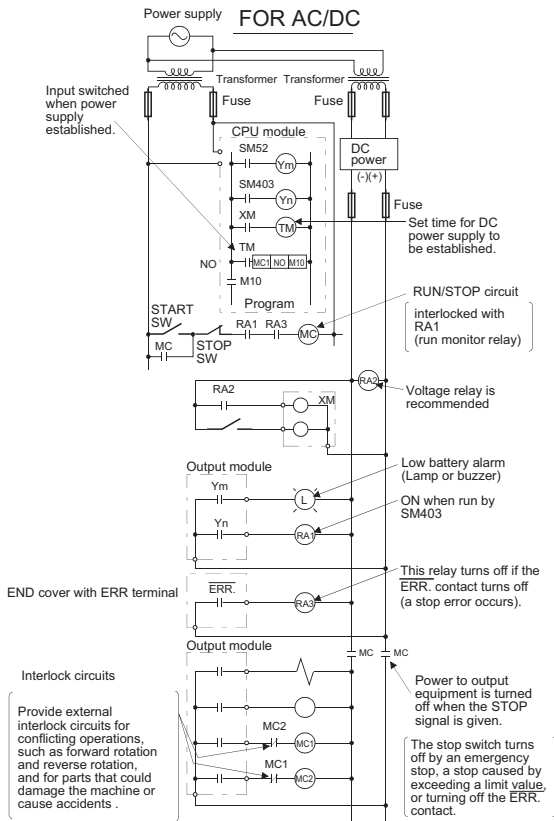

The power-on procedure is as follows:

- For AC and DC power

- 1) Power on the programmable controller.
- 2) Set the CPU module to RUN.
- 3) RA2 turns on when DC power is on.
- 4) Timer (TM) turns on when DC power establishes the rated voltage.
(The timer value is the period of time from when RA2 turns on to when DC power establishes the rated voltage. Set this value to 0.5 seconds.)
- 5) Turn on the start switch.
- 6) When the electromagnetic contactor (MC) turns on, the output devices will be activated by the program.
(If a voltage relay is used at RA2, no timer (TM) is required in the program.)

(2) Fail-safe measures against failure of CPU module

The self-diagnostic function can detect failure of the CPU module and a SD memory card. However, if an error occurs in an area such as I/O control part, the CPU module may not detect failure.

In this case, all points may turn on or off depending on the failure, and normal operation and safety cannot be ensured.

Although Mitsubishi programmable controllers are manufactured under strict quality control, it is recommended to configure external fail-safe circuits to prevent mechanical damage or accidents due to failure of the programmable controller.

6. SIGNAL LAYOUT OF THE CONNECTOR FOR EXTERNAL DEVICE CONNECTION







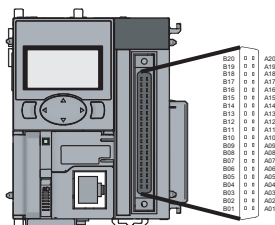

AFFECTATION DES SIGNAUX AU CONNECTEUR POUR RACCORDEMENT D'UN DISPOSITIF EXTERNE

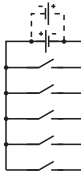
For the wiring diagram for the CPU module and the signal names of the connector, refer to the following.

Pour le câblage du module CPU avec les noms de signaux correspondants, voir ci-après.

- L02SCPU, L02CPU, L06CPU, L26CPU, L26CPU-BT



External wiring	Pin No.		I/O	Signal name									
	CH1 (Axis 1)	CH2 (Axis 2)		General-purpose I/O, Interrupt, and Pulse catch functions		High-speed counter function (1 (CH1) or 2 (CH2) is in □.)	Positioning function (1 (Axis 1) or 2 (Axis 2) is in □.)						
				Row B	Row A								
*1	B20	A20	Input	IN0-24V	IN2-24V	Phase A (PULSE A□)	+24V (PULSE A□-24V)	Zero signal (PG0□)	+24V (PG0□-24V)				
	B19	A19		IN0-DIFF	IN2-DIFF		Differential (PULSE A□-DIFF)		Differential (PG0□-DIFF)				
	B18	A18		IN0-COM	IN2-COM		COM (PULSE A□-COM)		COM (PG0□-COM)				
	B17	A17		IN1-24V	IN3-24V	Phase B (PULSE B□)	+24V (PULSE B□-24V)		Zero signal (PG0□)	+24V (PG0□-24V)			
	B16	A16		IN1-DIFF	IN3-DIFF		Differential (PULSE B□-DIFF)			Differential (PG0□-DIFF)			
	B15	A15		IN1-COM	IN3-COM		COM (PULSE B□-COM)			COM (PG0□-COM)			
	B14	A14		IN4-24V	IN5-24V	Phase Z (PULSE Z□)	+24V (PULSE Z□-24V)			Zero signal (PG0□)	+24V (PG0□-24V)		
	B13	A13		IN4-DIFF	IN5-DIFF		Differential (PULSE Z□-DIFF)				Differential (PG0□-DIFF)		
	B12	A12		IN4-COM	IN5-COM		COM (PULSE Z□-COM)				COM (PG0□-COM)		
		B11		A11	INCOM	INCOM	Input common				Input common		
		B10		A10	IN6	IN7	Function input signal (FUNC□)				External command signal (CHG□)		
		B09		A09	IN8	IN9	Latch counter input signal (LATCH□)				Drive unit ready signal (READY□)		
	B08	A08	INA	INB			Near-point watchdog signal (DOG□)						
	B07	A07	INC	IND			Upper limit signal (FLS□)						
	B06	A06	INE	INF			Lower limit signal (RLS□)						
	B05	A05	Out out	OUT0	OUT1	Coincidence output No.1 signal (EQU□1)		-					
	B04	A04		OUT2	OUT3	Coincidence output No.2 signal (EQU□2)		Deviation counter clear signal (CLEAR□)					
	B03	A03		OUT4	OUT5			CW/PULSE/Phase A (PULSE F□)					
	B02	A02		OUT6	OUT7			CCW/SIGN/Phase B (PULSE R□)					
	B01	A01		OUTCOM	OUTCOM	Output common		Output common					

English	French
Axis	Axe
CCW/SIGN/Phase	CCW/SIGN/Phase
CW/PULSE/Phase	CW/PULSE/Phase
Coincidence output No.1 signal	Signal de sortie coincidence N°1
Coincidence output No.2 signal	Signal de sortie coincidence N°2
Deviation counter clear signal	Signal d'annulation compteur de déviation
Differential	Différentiel
Drive unit ready signal	Signal READY d'unité de commande
External command signal	Signal de commande externe
External wiring	Câblage externe
Function input signal	Signal d'entrée fonction
General-purpose I/O, Interrupt, and Pulse catch functions	Entrée/sortie universelle, interruption et fonctions à signaux impulsionsnels
High-speed counter function (1 (CH1) or 2 (CH2) is in □.)	Fonction de comptage haute-vitesse (1 (CH1) ou 2 (CH2) comme indiqué en □.)
Input	Entrée

English	French
Input common	<i>Commun pour entrée</i>
Latch counter input signal	<i>Signal d'entrée compteur de verrouillage</i>
Load	<i>Charge</i>
Lower limit signal	<i>Signal de limite basse</i>
Near-point watchdog signal	<i>Signal de surveillance d'approche</i>
Output	<i>Sortie</i>
Output common	<i>Commun pour sortie</i>
Phase	<i>Phase</i>
Pin No.	<i>Broche N°</i>
Positioning function (1 (Axis 1) or 2 (Axis 2) is in □.)	<i>Fonction de positionnement (1 (axe 1) ou 2 (axe 2) comme indiqué en □.)</i>
Row	<i>Rangée</i>
Signal name	<i>Nom de signal</i>
Upper limit signal	<i>Signal de limite haute</i>
Zero signal	<i>Signal zéro</i>

• L02SCPU-P, L02CPU-P, L06CPU-P, L26CPU-P, L26CPU-PBT

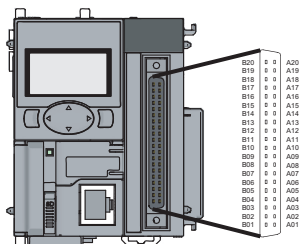

External wiring	Pin No.		I/O	Signal name							
	CH1 (Axis 1)	CH2 (Axis 2)		General-purpose I/O, Interrupt and Pulse catch functions		High-speed counter function (1 (CH1) or 2 (CH2) is in □.)		Positioning function (1 (Axis 1) or 2 (Axis 2) is in □.)			
				Row B	Row A						
*1	B20	A20	Input	IN0-24V	IN2-24V	Phase A (PULSE A□)	+24V (PULSE A□-24V)				
	B19	A19		IN0-DIFF	IN2-DIFF		Differential (PULSE A□-DIFF)				
	B18	A18		IN0-COM	IN2-COM		COM (PULSE A□-COM)				
	B17	A17		IN1-24V	IN3-24V	Phase B (PULSE B□)	+24V (PULSE B□-24V)				
	B16	A16		IN1-DIFF	IN3-DIFF		Differential (PULSE B□-DIFF)				
	B15	A15		IN1-COM	IN3-COM		COM (PULSE B□-COM)				
	B14	A14		IN4-24V	IN5-24V	Phase Z (PULSE Z□)	+24V (PULSE Z□-24V)			Zero signal (PG0□)	+24V (PG0□-24V)
	B13	A13		IN4-DIFF	IN5-DIFF		Differential (PULSE Z□-DIFF)				Differential (PG0□-DIFF)
B12	A12	IN4-COM	IN5-COM	COM (PULSE Z□-COM)	COM (PG0□-COM)						
	B11	A11	Input	INCOM	INCOM	Input common		Input common			
	B10	A10		IN6	IN7	Function input signal (FUNC□)		External command signal (CHG□)			
	B09	A09		IN8	IN9	Latch counter input signal (LATCH□)		Drive unit ready signal (READY□)			
	B08	A08		INA	INB			Near-point watchdog signal (DOG□)			
	B07	A07		INC	IND			Upper limit signal (FLS□)			
	B06	A06		INE	INF			Lower limit signal (RLS□)			
		B05		A05	Output	OUT0	OUT1	Coincidence output No.1 signal (EQU□1)			
B04		A04	OUT2	OUT3		Coincidence output No.2 signal (EQU□2)		Deviation counter clear signal (CLEAR□)			
B03		A03	OUT4	OUT5				CW/PULSE/Phase A (PULSE F□)			
B02		A02	OUT6	OUT7				CCW/SIGN/Phase B (PULSE R□)			
B01		A01	OUT24V	OUT24V		Output common		Output common			

English	French
Axis	<i>Axe</i>
CCW/SIGN/Phase	<i>CCW/SIGN/Phase</i>
CW/PULSE/Phase	<i>CW/PULSE/Phase</i>
Coincidence output No.1 signal	<i>Signal de sortie coïncidence N°1</i>
Coincidence output No.2 signal	<i>Signal de sortie coïncidence N°2</i>
Deviation counter clear signal	<i>Signal d'annulation compteur de déviation</i>
Differential	<i>Différentiel</i>
Drive unit ready signal	<i>Signal READY d'unité de commande</i>
External command signal	<i>Signal de commande externe</i>
External wiring	<i>Câblage externe</i>
Function input signal	<i>Signal d'entrée fonction</i>
General-purpose I/O, Interrupt, and Pulse catch functions	<i>Entrée/sortie universelle, interruption et fonctions à signaux impulsionsnels</i>
High-speed counter function (1 (CH1) or 2 (CH2) is in □.)	<i>Fonction de comptage haute-vitesse (1 (CH1) ou 2 (CH2) comme indiqué en □.)</i>
Input	<i>Entrée</i>
Input common	<i>Commun pour entrée</i>
Latch counter input signal	<i>Signal d'entrée compteur de verrouillage</i>
Load	<i>Charge</i>
Lower limit signal	<i>Signal de limite basse</i>
Near-point watchdog signal	<i>Signal de surveillance d'approche</i>
Output	<i>Sortie</i>
Output common	<i>Commun pour sortie</i>
Phase	<i>Phase</i>
Pin No.	<i>Broche N°</i>
Positioning function (1 (Axis 1) or 2 (Axis 2) is in □.)	<i>Fonction de positionnement (1 (axe 1) ou 2 (axe 2) comme indiqué en □.)</i>
Row	<i>Rangée</i>
Signal name	<i>Nom de signal</i>
Upper limit signal	<i>Signal de limite haute</i>
Zero signal	<i>Signal zéro</i>

*1 The external wiring is shown below. (The same is applied to phases B and Z.)

*1 *Le câblage externe est représenté ci-dessous. (Identique pour les phases B et Z.)*

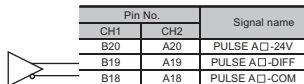
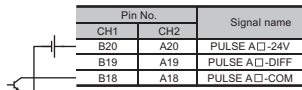

English	French	English	French
Pin No.	Broche N°	Signal name	Nom de signal

The table below shows applicable connectors connected to the CPU module.

When wiring, use applicable wires and an appropriate tightening torque.

Le tableau ci-dessous indique quels connecteurs s'utilisent pour les raccordements au module CPU.

Pour le câblage, utiliser les fils et couples de serrage prescrits.

Mitsubishi 40-pin connector Connecteur 40-broches Mitsubishi		Wire Fil			
Model Modèle	Tightening torque Couple de serrage	Diameter Diamètre	Type Type	Material Matériau	Temperature rating Gamme de température
A6CON1	0.20 to 0.29N·m 0,20 à 0,29 N·m	22AWG	Stranded Torsadé	Copper Cuivre	75°C or more 75 °C ou plus
A6CON2		28 to 24AWG 28 à 24 AWG			
A6CON3		28AWG	Solid Monobrin		
A6CON4		30AWG	Stranded Torsadé		
		22AWG			

For the CC-Link dedicated cable wiring for the L26CPU-BT or the L26CPU-PBT, refer to the following.

Pour le câblage par câbles dédiés sur les L26CPU-BT et L26CPU-PBT, voir ce qui suit.

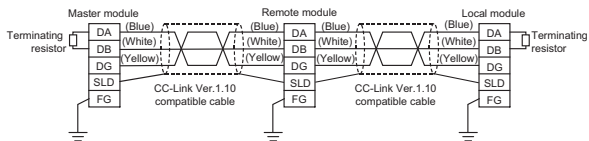

English	French	English	French
Blue	<i>bleu</i>	CC-Link Ver.1.10 compatible cable	<i>Câble compatibles CC-Link Ver.1.10</i>
Local module	<i>Module local</i>	Remote module	<i>Module distant</i>
Master module	<i>Module maître</i>	Terminating resistor	<i>Résistance d'extrémité</i>
White	<i>blanc</i>	Yellow	<i>jaune</i>

The table below shows an applicable solderless terminal connected to the terminal block.

When wiring, use applicable wires and an appropriate tightening torque. Use UL listed solderless terminals and, for processing, use a tool recommended by their manufacturer. Also, sleeved solderless terminals cannot be used.

Le tableau ci-dessous indique quelles bornes sans soude s'utilisent pour les raccordements sur la plaque à bornes.

Pour le câblage, utiliser les fils et couples de serrage prescrits. Utiliser les bornes sans soude répertoriées par UL et, pour le montage, utiliser l'outil recommandé par le fabricant de ces bornes. En outre, il ne faut pas utiliser de bornes sans soude sous manchon.

Solderless terminal <i>Borne sans soude</i>		Wire <i>Fil</i>			
Model <i>Modèle</i>	Tightening torque <i>Couple de serrage</i>	Diameter <i>Diamètre</i>	Type <i>Type</i>	Material <i>Matériau</i>	Temperature rating <i>Gamme de température</i>
1.25-3	0.42 to 0.58N·m <i>0,42 à 0,58 N·m</i>	22 to 16AWG <i>22 à 16 AWG</i>	Stranded <i>Torsadé</i>	Copper <i>Cuivre</i>	60°C or more <i>60 °C ou plus</i>

WARRANTY

Please confirm the following product warranty details before using this product.

1. Gratis Warranty Term and Gratis Warranty Range

If any faults or defects (hereinafter "Failure") found to be the responsibility of Mitsubishi occurs during use of the product within the gratis warranty term, the product shall be repaired at no cost via the sales representative or Mitsubishi Service Company.

However, if repairs are required onsite at domestic or overseas location, expenses to send an engineer will be solely at the customer's discretion. Mitsubishi shall not be held responsible for any re-commissioning, maintenance, or testing on-site that involves replacement of the failed module.

[Gratis Warranty Term]

The gratis warranty term of the product shall be for one year after the date of purchase or delivery to a designated place.

Note that after manufacture and shipment from Mitsubishi, the maximum distribution period shall be six (6) months, and the longest gratis warranty term after manufacturing shall be eighteen (18) months. The gratis warranty term of repair parts shall not exceed the gratis warranty term before repairs.

[Gratis Warranty Range]

- (1) The range shall be limited to normal use within the usage state, usage methods and usage environment, etc., which follow the conditions and precautions, etc., given in the instruction manual, user's manual and caution labels on the product.
- (2) Even within the gratis warranty term, repairs shall be charged for in the following cases.
 1. Failure occurring from inappropriate storage or handling, carelessness or negligence by the user. Failure caused by the user's hardware or software design.
 2. Failure caused by unapproved modifications, etc., to the product by the user.
 3. When the Mitsubishi product is assembled into a user's device, Failure that could have been avoided if functions or structures, judged as necessary in the legal safety measures the user's device is subject to or as necessary by industry standards, had been provided.
 4. Failure that could have been avoided if consumable parts (battery, backlight, fuse, etc.) designated in the instruction manual had been correctly serviced or replaced.
 5. Failure caused by external irresistible forces such as fires or abnormal voltages, and Failure caused by force majeure such as earthquakes, lightning, wind and water damage.
 6. Failure caused by reasons unpredictable by scientific technology standards at time of shipment from Mitsubishi.
 7. Any other failure found not to be the responsibility of Mitsubishi or that admitted not to be so by the user.

2. Onerous repair term after discontinuation of production

- (1) Mitsubishi shall accept onerous product repairs for seven (7) years after production of the product is discontinued.
Discontinuation of production shall be notified with Mitsubishi Technical Bulletins, etc.
- (2) Product supply (including repair parts) is not available after production is discontinued.

3. Overseas service

Overseas, repairs shall be accepted by Mitsubishi's local overseas FA Center. Note that the repair conditions at each FA Center may differ.

4. Exclusion of loss in opportunity and secondary loss from warranty liability

Regardless of the gratis warranty term, Mitsubishi shall not be liable for compensation to:

- (1) Damages caused by any cause found not to be the responsibility of Mitsubishi.
- (2) Loss in opportunity, lost profits incurred to the user by Failures of Mitsubishi products.
- (3) Special damages and secondary damages whether foreseeable or not, compensation for accidents, and compensation for damages to products other than Mitsubishi products.
- (4) Replacement by the user, maintenance of on-site equipment, start-up test run and other tasks.

5. Changes in product specifications

The specifications given in the catalogs, manuals or technical documents are subject to change without prior notice.

REVISIONS

* The manual number is given on the bottom right of the cover.

Print Date	*Manual Number	Revision
December 2009	IB(NA)-0800456-A	First edition
January 2010	IB(NA)-0800456-B	The description of L6EC-ET is added.
June 2010	IB(NA)-0800456-C	Correction of errors in writing and safety precautions
October 2010	IB(NA)-0800456-D	Addition of descriptions of EN61131-2:2007
January 2011	IB(NA)-0800456-E	Addition of descriptions of CC-Link IE Field Network
April 2011	IB(NA)-0800456-F	The description of L02CPU-P and L26CPU-PBT is added.
July 2011	IB(NA)-0800456-G	The description of L6EXB, L6EXE, LC06E, LC10E, and LC30E is added.
August 2011	IB(NA)-0800456-H	Addition of descriptions of SAFETY PRECAUTIONS (Chinese)
November 2012	IB(NA)-0800456-I	The description of L02SCPU and L26CPU is added.
January 2013	IB(NA)-0800456-J	The description of L06CPU is added.
April 2013	IB(NA)-0800456-K	The description of L02SCPU-P, L06CPU-P, and L26CPU-P is added.
May 2014	IB(NA)-0800456-L	Addition of descriptions of cUL
May 2015	IB(NA)-0800456-M	The description of NZ1MEM-□GBSD is added.
October 2015	IB(NA)-0800456-N	Addition of descriptions of measures against the damage of LCP module joint levers

This manual confers no industrial property rights or any rights of any other kind, nor does it confer any patent licenses. Mitsubishi Electric Corporation cannot be held responsible for any problems involving industrial property rights which may occur as a result of using the contents noted in this manual.

Country/Region Sales office/Tel

USA	Mitsubishi Electric Automation Inc. 500 Corporate Woods Parkway, Vernon Hills, IL 60061, USA Tel : +1-847-478-2100
Brazil	MELCO-TEC Representacao Comercial e Assessoria Tecnica Ltda. Av. Paulista, 1439, cj74, Bela Vista, Sao Paulo CEP: 01311-200-SP Brazil Tel : +55-11-3146-2200
Germany	Mitsubishi Electric Europe B.V. German Branch Gothaer Strasse 8, D-40880 Ratingen, Germany Tel : +49-2102-486-0
UK	Mitsubishi Electric Europe B.V. UK Branch Travellers Lane, Hatfield, Hertfordshire, AL10 8XB, UK. Tel : +44-1707-27-6100
Italy	Mitsubishi Electric Europe B.V. Italian Branch Viale Colleoni 7-20864 Agrate Brianza (Milano), Italy Tel : +39-039-60531
Spain	Mitsubishi Electric Europe B.V. Spanish Branch Carretera de Rubi 76-80.AC.420, E-08190 Sant Cugat del Valles (Barcelona), Spain Tel : +34-93-565-3131
France	Mitsubishi Electric Europe B.V. French Branch 25, Boulevard des Bouvets, F-92741 Nanterre Cedex, France Tel : +33-1-5568-5568
Czech Republic	Mitsubishi Electric Europe B.V.-o.s.Czech office Avenir Business Park, Radicka 751/113e, 158 00 Praha5, Czech Republic Tel : +420-251-551-470
Poland	Mitsubishi Electric Europe B.V. Polish Branch ul. Krakowska 50, 32-083 Balice, Poland Tel : +48-12-630-47-00
Russia	Mitsubishi Electric Europe B.V. Russian Branch St.Petersburg office Piskarevsky pr. 2, bld 2, lit "Sch", BC "Benua", office 720; 195027, St. Petersburg, Russia Tel : +7-812-633-3497

Country/Region Sales office/Tel

South Africa	CBI-Electric. Private Bag 2016, ZA-1600 Isando, South Africa Tel : +27-11-977-0770
China	Mitsubishi Electric Automation (China) Ltd. No.1386 Hongqiao Road, Mitsubishi Electric Automation Center, Changning District, Shanghai, China Tel : +86-21-2322-3030
Taiwan	Setsuyo Enterprise Co., Ltd. 6F., No.105, Wugong 3rd Road, Wugu District, New Taipei City 24889, Taiwan, R.O.C. Tel : +886-2-2299-2499
Korea	Mitsubishi Electric Automation Korea Co., Ltd. 3F, 1480-6, Gayang-Dong, Gangseo-Gu, Seoul, 157-200, Korea Tel : +82-2-3660-9530
Singapore	Mitsubishi Electric Asia Pte, Ltd. Industrial Division 307, Alexandra Road, Mitsubishi Electric Building, Singapore, 159943 Tel : +65-6470-2308
Thailand	Mitsubishi Electric Automation (Thailand) Co., Ltd. Bang-Chan Industrial Estate No.111 Soi Serithai 54, T.Kannayao, A.Kannayao, Bangkok 10230 Thailand Tel : +66-2906-3238
Indonesia	P. T. Autoteknindo Sumber Makmur Muara Karang Selatan, Block A / Utara No.1 Kav. No. 11, Kawasan Industri Pergudangan, Jakarta-Utara 14440, P.O. Box 5045, Indonesia Tel : +62-21-663-0833
India	Mitsubishi Electric India Pvt. Ltd. 2nd Floor, Tower A & B, Cyber Greens, DLF Cyber City, DLF Phase-III, Gurgaon-122002 Haryana, India Tel : +91-124-463-0300
Australia	Mitsubishi Electric Australia Pty. Ltd. 348 Victoria Road PO BOX11, Rydalmere, N.S.W 2116, Australia Tel : +61-2-9684-7777

MITSUBISHI ELECTRIC CORPORATION

HEAD OFFICE : TOKYO BUILDING, 2-7-3 MARUNOUCHI, CHIYODA-KU, TOKYO 100-8310, JAPAN
NAGOYA WORKS : 1-14, YADA-MINAMI 5-CHOME, HIGASHI-KU, NAGOYA, JAPAN

When exported from Japan, this manual does not require application to the Ministry of Economy, Trade and Industry for service transaction permission.

Specifications subject to change without notice.