

General-Purpose AC Servo

MITSUBISHI SERVO AMPLIFIERS & MOTORS  
**MELSERVO-J4**

Instructions and Cautions for Drive of HC/HA  
Series Servo Motor with MR-J4-(DU)\_B\_-RJ020

## ● Safety Instructions ●

Please read the instructions carefully before using the equipment.

To use the equipment correctly, do not attempt to install, operate, maintain, or inspect the equipment until you have read through this guide, Installation guide, and appended documents carefully. Do not use the equipment until you have a full knowledge of the equipment, safety information and instructions.

In this guide the safety instruction levels are classified into "WARNING" and "CAUTION".



Indicates that incorrect handling may cause hazardous conditions, resulting in death or severe injury.



Indicates that incorrect handling may cause hazardous conditions, resulting in medium or slight injury to personnel or may cause physical damage.

Note that the CAUTION level may lead to a serious consequence according to conditions.

Please follow the instructions of both levels because they are important to personnel safety.

What must not be done and what must be done are indicated by the following diagrammatic symbols.



Indicates what must not be done. For example, "No Fire" is indicated by .



Indicates what must be done. For example, grounding is indicated by .

In this guide, instructions at a lower level than the above, instructions for other functions, and so on are classified into "POINT".

After reading this Instruction Manual, keep it accessible to the operator.

## 1. To prevent electric shock, note the following

### WARNING

- Before wiring or inspection, turn off the power and wait for 15 minutes or more (20 minutes or more for 30 kW or more) until the charge lamp turns off. Then, confirm that the voltage between P+ and N- (L+ and L- for 30 kW or more) is safe with a voltage tester and others. Otherwise, an electric shock may occur. In addition, when confirming whether the charge lamp is off or not, always confirm it from the front of the servo amplifier.
- Ground the servo amplifier and servo motor securely.
- Any person who is involved in wiring and inspection should be fully competent to do the work.
- Do not attempt to wire the servo amplifier and servo motor until they have been installed. Otherwise, it may cause an electric shock.
- Do not operate switches with wet hands. Otherwise, it may cause an electric shock.
- The cables should not be damaged, stressed, loaded, or pinched. Otherwise, it may cause an electric shock.
- During power-on or operation, do not open the front cover of the servo amplifier. Otherwise, it may cause an electric shock.
- Do not operate the servo amplifier with the front cover removed. High-voltage terminals and charging area are exposed and you may get an electric shock.
- Except for wiring and periodic inspection, do not remove the front cover of the servo amplifier even if the power is off. The servo amplifier is charged and you may get an electric shock.
- To prevent an electric shock, always connect the protective earth (PE) terminal (marked  $\oplus$ ) of the servo amplifier to the protective earth (PE) of the cabinet.
- To avoid an electric shock, insulate the connections of the power supply terminals.

## 2. To prevent fire, note the following

### CAUTION

- Install the servo amplifier, servo motor, and regenerative resistor on incombustible material. Installing them directly or close to combustibles will lead to smoke or a fire.
- Always connect a magnetic contactor between the power supply and the main circuit power supply (L1, L2, and L3) of the servo amplifier, in order to configure a circuit that shuts down the power supply on the side of the servo amplifier's power supply. If a magnetic contactor is not connected, continuous flow of a large current may cause smoke or a fire when the servo amplifier malfunctions.
- In order to configure a circuit that shuts down the power supply on the side of the servo amplifier's power supply, always connect one molded-case circuit breaker or fuse per one servo amplifier between the power supply and the power supply (L1, L2, and L3) of a servo amplifier. If a molded-case circuit breaker or fuse is not connected, continuous flow of a large current may cause smoke or a fire when the servo amplifier malfunctions.
- When using the regenerative resistor, switch power off with the alarm signal. Otherwise, a regenerative transistor malfunction or the like may overheat the regenerative resistor, causing smoke or a fire.
- Provide adequate protection to prevent screws and other conductive matter, oil and other combustible matter from entering the servo amplifier, servo motor, and MR-J4-T20.
- Always connect a molded-case circuit breaker to the power supply of the servo amplifier.

### 3. To prevent injury, note the following

#### CAUTION

- Only the voltage specified in the Instruction Manual should be applied to each terminal. Otherwise, a burst, damage, etc. may occur.
- Connect cables to the correct terminals. Otherwise, a burst, damage, etc. may occur.
- Ensure that polarity (+/-) is correct. Otherwise, a burst, damage, etc. may occur.
- The servo amplifier heat sink, regenerative resistor, servo motor, etc. may be hot while power is on or for some time after power-off. Take safety measures, e.g. provide covers, to avoid accidentally touching the parts (cables, etc.) by hand.

### 4. Additional instructions

The following instructions should also be fully noted. Incorrect handling may cause a malfunction, injury, electric shock, fire, etc.

#### (1) Transportation and installation

#### CAUTION

- Transport the products correctly according to their mass.
- Stacking in excess of the specified number of product packages is not allowed.
- Do not hold the front cover when transporting the servo amplifier. Otherwise, it may drop.
- Install the servo amplifier and the servo motor in a load-bearing place in accordance with the Instruction Manual.
- Do not get on or put heavy load on the equipment.
- The equipment must be installed in the specified direction.
- Leave specified clearances between the servo amplifier and the cabinet walls or other equipment.
- Do not install or operate the servo amplifier and MR-J4-T20 which have been damaged or have any parts missing.
- Do not block the intake and exhaust areas of the servo amplifier and MR-J4-T20. Otherwise, it may cause a malfunction.
- Do not drop or strike the servo amplifier, servo motor, and MR-J4-T20. Isolate them from all impact loads.
- When you keep or use the equipment, please fulfill the following environment.

Item		Environment
Ambient temperature	Operation	0 °C to 55 °C (non-freezing)
	Storage	-20 °C to 65 °C (non-freezing)
Ambient humidity	Operation	90 %RH or less (non-condensing)
	Storage	
Ambience		Indoors (no direct sunlight), free from corrosive gas, flammable gas, oil mist, dust, and dirt
Altitude		2000 m or less above sea level (For the altitude value for an option, contact your local sales office.)
Vibration resistance		5.9 m/s <sup>2</sup> , at 10 Hz to 55 Hz (directions of X, Y and Z axes)

- When the product has been stored for an extended period of time, contact your local sales office.
- When handling the servo amplifier and MR-J4-T20, be careful about the edged parts such as corners of them.

## ⚠ CAUTION

- The servo amplifier and MR-J4-T20 must be installed in a metal cabinet.
- When fumigants that contain halogen materials such as fluorine, chlorine, bromine, and iodine are used for disinfecting and protecting wooden packaging from insects, they cause malfunction when entering our products. Please take necessary precautions to ensure that remaining materials from fumigant do not enter our products, or treat packaging with methods other than fumigation (heat method). Additionally, disinfect and protect wood from insects before packing products.

### (2) Wiring

## ⚠ CAUTION

- Wire the equipment correctly and securely. Otherwise, the servo motor may operate unexpectedly.
- Do not install a power capacitor, surge killer, or radio noise filter (optional FR-BIF(-H)) on the servo amplifier output side.
- To avoid a malfunction, connect the wires to the correct phase terminals (U, V, and W) of the servo amplifier and servo motor.
- Connect the servo amplifier power output (U, V, and W) to the servo motor power input (U, V, and W) directly. Do not let a magnetic contactor, etc. intervene. Otherwise, it may cause a malfunction.

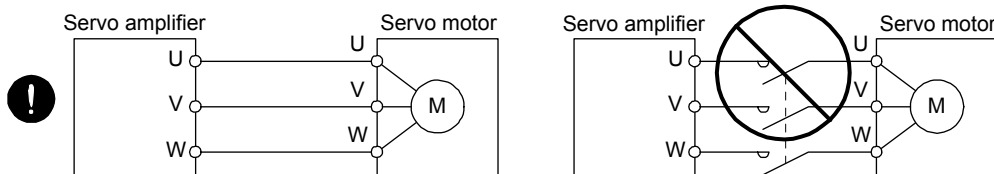

- The connection diagrams in this guide are shown for sink interfaces, unless stated otherwise.
- The surge absorbing diode installed to the DC relay for control output should be fitted in the specified direction. Otherwise, the emergency stop and other protective circuits may not operate.

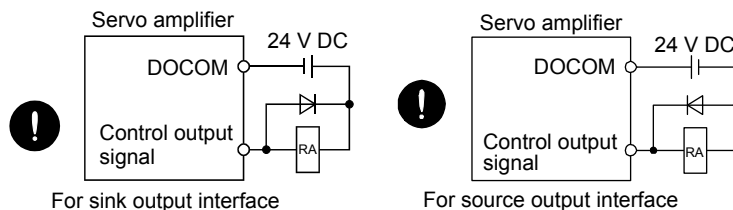

- When the cable is not tightened enough to the terminal block, the cable or terminal block may generate heat because of the poor contact. Be sure to tighten the cable with specified torque.
- Connecting a servo motor of the wrong axis to U, V, W, or CN2 of the servo amplifier may cause a malfunction.

### (3) Test run and adjustment

## ⚠ CAUTION

- Before operation, check the parameter settings. Improper settings may cause some machines to operate unexpectedly.
- Never make a drastic adjustment or change to the parameter values as doing so will make the operation unstable.
- Do not get close to moving parts during the servo-on status.

#### (4) Usage

### ⚠ CAUTION

- When it is assumed that a hazardous condition may occur due to a power failure or product malfunction, use a servo motor with an external brake to prevent the condition.
- Do not disassemble, repair, or modify the equipment.
- Before resetting an alarm, make sure that the run signal of the servo amplifier is off in order to prevent a sudden restart. Otherwise, it may cause an accident.
- Use a noise filter, etc. to minimize the influence of electromagnetic interference. Electromagnetic interference may be given to the electronic equipment used near the servo amplifier.
- Burning or breaking a servo amplifier may cause a toxic gas. Do not burn or break it.
- Use the servo amplifier with the specified servo motor.
- The electromagnetic brake on the servo motor is designed to hold the motor shaft and should not be used for ordinary braking.
- For such reasons as service life and mechanical structure (e.g. where a ball screw and the servo motor are coupled via a timing belt), the electromagnetic brake may not hold the motor shaft. To ensure safety, install a stopper on the machine side.

#### (5) Corrective actions

### ⚠ CAUTION

- When it is assumed that a hazardous condition may occur due to a power failure or product malfunction, use a servo motor with an electromagnetic brake or external brake to prevent the condition.
- Configure an electromagnetic brake circuit so that it is activated also by an external emergency stop switch.

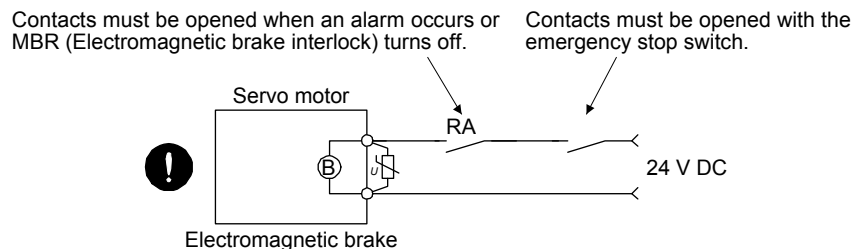

- When any alarm has occurred, eliminate its cause, ensure safety, and deactivate the alarm before restarting operation.
- Provide an adequate protection to prevent unexpected restart after an instantaneous power failure.

#### (6) Maintenance, inspection and parts replacement

### ⚠ CAUTION

- With age, the electrolytic capacitor of the servo amplifier will deteriorate. To prevent a secondary accident due to a malfunction, it is recommended that the electrolytic capacitor be replaced every 10 years when it is used in general environment. Please contact your local sales office.
- When using the servo amplifier that has not been energized for an extended period of time, contact your local sales office.

## (7) General instruction

● To illustrate details, the equipment in the diagrams of this Instruction Manual may have been drawn without covers and safety guards. When the equipment is operated, the covers and safety guards must be installed as specified. Operation must be performed in accordance with this Instruction Manual.

### «About the manual»

You must have this guide and the following manuals to use this servo. Ensure to prepare them to use the servo safely.

Servo amplifiers and drive units are written as servo amplifiers in this guide under certain circumstances, unless otherwise stated.

### Relevant manuals

Manual name	Manual No.
MR-J4-(DU)_B_-RJ020 MR-J4-T20 Servo Amplifier Instruction Manual	SH(NA)030125
Conversion unit for SSCNET of MR-J2S-B MR-J4-T20 Instruction Manual (Packed with MR-J4-T20.)	IB(NA)0300204
MR-J2S-_B Servo Amplifier Instruction Manual	SH(NA)030007
MELSERVO Servo Motor Instruction Manual	SH(NA)3181
MR-J2S-_B-PY096/S096 (5.7kW) Instruction Manual (Note)	SH(NA)030035

Note. It is necessary for using the fully closed loop system.

### «Wiring»

Wires mentioned in this guide are selected based on the ambient temperature of 40 °C.

## CONTENTS

<b>1. INTRODUCTION</b>	<b>1- 1 to 1- 2</b>
<b>2. COMBINATION WITH HC SERIES/HA SERIES SERVO MOTOR</b>	<b>2- 1 to 2- 2</b>
<b>3. PRECAUTIONS</b>	<b>3- 1 to 3- 2</b>
3.1 When you replace MR-J2S-_B_ servo amplifier with MR-J4-_B_-RJ020 servo amplifier .....	3- 1
3.2 Difference from using HG series servo motor .....	3- 1
3.3 Gain adjustment .....	3- 2
<b>4. CHARACTERISTICS</b>	<b>4- 1 to 4-16</b>
4.1 Overload protection characteristics .....	4- 1
4.2 Power supply capacity and generated loss .....	4- 4
4.3 Dynamic brake characteristics .....	4- 8
4.4 Cable bending life .....	4-13
4.5 Inrush currents at power-on of main circuit and control circuit .....	4-14
4.5.1 Inrush current of servo amplifier .....	4-14
4.5.2 Inrush current of converter unit/drive unit .....	4-16
<b>5. OPTIONS AND PERIPHERAL EQUIPMENT</b>	<b>5- 1 to 5-30</b>
5.1 Combinations of encoder cables .....	5- 2
5.2 Encoder cable list .....	5- 3
5.3 Detail of the encoder cable .....	5- 4
5.4 Regenerative option .....	5-13
5.4.1 Regenerative option of servo amplifier .....	5-13
5.4.2 Regenerative option of converter unit .....	5-14
<b>6. SELECTION EXAMPLE OF WIRES</b>	<b>6- 1 to 6- 6</b>
6.1 Servo amplifier .....	6- 1
6.2 Converter unit/drive unit .....	6- 5
<b>7. FULLY CLOSED LOOP SYSTEM</b>	<b>7- 1 to 7- 4</b>
7.1 System configuration .....	7- 1
7.2 Load-side encoder .....	7- 2
7.2.1 Linear encoder .....	7- 3
7.2.2 Rotary encoder .....	7- 4
7.2.3 Configuration diagram of encoder cable .....	7- 4





# 1. INTRODUCTION

---

## 1. INTRODUCTION

This guide explains instructions and cautions for drive of HC/HA series servo motor with MR-J4-(DU)\_B\_-RJ020 servo amplifier. Refer to "MR-J4-(DU)\_B\_-RJ020 MR-J4-T20 Servo Amplifier Instruction Manual" for details of functions, specifications, startup, etc. When you replace an amplifier with an MR-J4-(DU)\_B\_-RJ020 servo amplifier practically using existing wiring, use the MR-J2S-\_B\_ renewal tools manufactured by Mitsubishi Electric System & Service.

MR-J2S-\_B\_ renewal tools are for using an MR-J4-(DU)\_B\_-RJ020 servo amplifier as a replacement of MR-J2S-\_B\_ servo amplifier.

For the details of the MR-J2S-\_B\_ renewal tools, contact your local sales office.



## 2. COMBINATION WITH HC SERIES/HA SERIES SERVO MOTOR

### 2. COMBINATION WITH HC SERIES/HA SERIES SERVO MOTOR

Refer to the following table for combination with HC series/HA series servo motor.

#### (1) 200 V class

Servo amplifier/ drive unit	Servo motor						
	HC-KFS	HC-MFS	HC-SFS	HC-RFS	HC-UFS	HA-LFS	HC-LFS
MR-J4-10B-RJ020	053 13	053 13			13		
MR-J4-20B-RJ020	23	23			23		
MR-J4-40B-RJ020	43	43			43		
MR-J4-60B-RJ020			52 53				52
MR-J4-70B-RJ020	46 410 73	73			(Note 2) 72 73		
MR-J4-100B-RJ020			81 102 103				102
MR-J4-200B-RJ020			121 201 152 202 153 203	103 153	(Note 2) 152		152
MR-J4-350B-RJ020			301 352 353	203	(Note 2) 202		202
MR-J4-500B-RJ020			502	(Note 2) 353 503	(Note 2) 352 (Note 2) 502	502	302
MR-J4-700B-RJ020			702			(Note 1) 601 (Note 1) 701M 702	
MR-J4-11KB-RJ020						(Note 1) 801 (Note 1) 11K1M 11K2 (Note 1) 12K1	
MR-J4-15KB-RJ020						(Note 1) 15K1 (Note 1) 15K1M 15K2	
MR-J4-22KB-RJ020						(Note 1) 20K1 (Note 1) 22K1M 22K2 (Note 1) 25K1	
MR-J4-DU30KB-RJ020						(Note 1) 30K1 (Note 1) 30K1M 30K2	
MR-J4-DU37KB-RJ020						(Note 1) 37K1 (Note 1) 37K1M 37K2	

- Note 1. When you use this servo motor, please contact your local sales office.  
 2. Supported by servo amplifiers with software version A1 or later.

## 2. COMBINATION WITH HC SERIES/HA SERIES SERVO MOTOR

### (2) 400 V class

Servo amplifier/ drive unit	Servo motor	
	HC-SFS	HA-LFS
MR-J4-60B4-RJ020	524	
MR-J4-100B4-RJ020	1024	
MR-J4-200B4-RJ020	1524 2024	
MR-J4-350B4-RJ020	3524	
MR-J4-500B4-RJ020	5024	
MR-J4-700B4-RJ020	7024	(Note) 6014 (Note) 701M4
MR-J4-11KB4-RJ020		(Note) 8014 (Note) 11K1M4 (Note) 11K24 (Note) 12K14
MR-J4-15KB4-RJ020		(Note) 15K14 (Note) 15K1M4 (Note) 15K24
MR-J4-22KB4-RJ020		(Note) 20K14 (Note) 22K1M4 (Note) 22K24
MR-J4-DU30KB4- RJ020		(Note 1) 25K14 (Note 1) 30K14 (Note 1) 30K1M4 30K24
MR-J4-DU37KB4- RJ020		(Note 1) 37K14 (Note 1) 37K1M4 37K24
MR-J4-DU45KB4- RJ020		(Note 1) 45K1M4 45K24
MR-J4-DU55KB4- RJ020		(Note 1) 50K1M4 55K24

Note. When you use this servo motor, please contact your local sales office.

### (3) 100 V class

Servo amplifier	Servo motor	
	HC-KFS	HC-MFS
MR-J4-10B1-RJ020	053 13	053 13
MR-J4-20B1-RJ020	23	23
MR-J4-40B1-RJ020	43	43

### 3. PRECAUTIONS

#### 3. PRECAUTIONS

##### 3.1 When you replace MR-J2S-\_B\_ servo amplifier with MR-J4-\_B\_-RJ020 servo amplifier

Please note the following when replacing MR-J2S-\_B\_ servo amplifier with MR-J4-\_B\_-RJ020 servo amplifier.

- (1) The mounting holes are not interchangeable.
- (2) The dimensions of an MR-J4-\_B\_-RJ020 servo amplifier with MR-J4-T20 can be larger than those of MR-J2S-\_B\_ servo amplifier.
- (3) The wire sizes can be different from those of MR-J2S-\_B\_ servo amplifier.
- (4) For the servo amplifier of 7 kW or less, the dynamic brake characteristics are different from those of MR-J2S-\_B\_ servo amplifier. When an HA series servo motor is used with the servo amplifier of 11 kW or more, use the external dynamic brake for MR-J2S. The external dynamic brake for MR-J4 cannot be used.
- (5) It may be required to change existing equipment program because the initialization time after power on is different between MR-J2S-\_B\_ servo amplifier and MR-J4-\_B\_-RJ020 servo amplifier. Especially when using it in vertical motion applications, please be careful of electromagnetic brake release time. The moving part can fall.
- (6) For options and peripheral equipment which are not described in this chapter, select them referring contents in chapter 11 and 14 of "MR-J4-(DU)\_B\_-RJ020 MR-J4-T20 Servo Amplifier Instruction Manual".

##### 3.2 Difference from using HG series servo motor

###### (1) Servo amplifier power supply specifications

The following shows items which differ from using an HG series servo motor.

###### (a) 200 V class

Model: MR-J4-_B_-RJ020		10B	20B	40B	60B	70B	100B	200B	350B	500B	700B	11KB	15KB	22KB	
Main circuit power supply input	Voltage/ Frequency	3-phase 200 V AC to 230 V AC, 50 Hz/60 Hz or 1-phase 230 V AC, 50 Hz/60 Hz					3-phase 200 V AC to 230 V AC, 50 Hz/60 Hz								
	Permissible voltage fluctuation	3-phase 200 V AC to 230 V AC: 170 V AC to 253 V AC 1-phase 170 V AC: 207 V AC to 253 V AC					3-phase 170 V AC to 253 V AC								

###### (b) 100 V class

Model: MR-J4-_B_-RJ020		10B1	20B1	40B1
Main circuit power supply input	Voltage/ Frequency	1-phase 100 V AC to 120 V AC, 50 Hz/60 Hz		
	Permissible voltage fluctuation	85 V AC to 127 V AC		

### 3. PRECAUTIONS

---

(2) Specifications of the converter unit power supply

The following shows items which differ from using an HG series servo motor.

200 V class

Model: MR-CR_		55K
Main circuit power supply input	Voltage/frequency	3-phase 200 V AC to 230 V AC, 50 Hz/60 Hz
	Permissible voltage fluctuation	3-phase 170 V AC to 253 V AC

(3) Startup in the absolute position detection system

The [AL. 25 Absolute position erased] occurrence at the first power-on does not mean an alarm. To cancel the alarm, wait for three minutes with power-on and cycle the power. If power is switched on at the servo motor speed of 500 r/min or higher, position mismatch may occur due to external force or the like. Power must therefore be switched on when the servo motor is at a stop.

(4) MR-BAT6V1SET battery

The following shows items which differ from using an HG series servo motor.

Item	Description
Maximum speed at power failure [r/min]	500
Battery backup time	Approximately 10,000 hours (equipment power supply: off, ambient temperature: 20 °C)

(5) MR-BAT6V1BJ battery for junction battery cable

When an HC series or HA series servo motor is used, the MR-BAT6V1BJ battery for junction battery cable cannot be used.

#### 3.3 Gain adjustment

When using [Pr. 13 Position loop gain 1] of MR-J4-\_B\_-RJ020 servo amplifier and MR-J2S-\_B\_ servo amplifier simultaneously such as in the interpolation mode, check droop pulses for each axis and readjust gains.

# 4. CHARACTERISTICS

## 4. CHARACTERISTICS

### 4.1 Overload protection characteristics

An electronic thermal is built in the servo amplifier to protect the servo motor, servo amplifier and servo motor power wires from overloads.

[AL. 50 Overload 1] occurs if overload operation performed is above the electronic thermal protection curve shown in fig. 4.1. [AL. 51 Overload 2] occurs if the maximum current is applied continuously for several seconds due to machine collision, etc. Use the equipment on the left-side area of the continuous or broken line in the graph.

For the system where the unbalanced torque occurs, such as a vertical axis system, it is recommended that the unbalanced torque of the machine be kept at 70% or less of the motor's rated torque.

This servo amplifier has servo motor overload protective function. (The servo motor overload current (full load current) is set on the basis of 115% rated current of the servo amplifier.)

The following table shows combinations of each servo motor and graph of overload protection characteristics.

Servo motor							Graph of overload protection characteristics
HC-KFS	HC-MFS	HC-UFS	HC-SFS	HC-LFS	HC-RFS	HA-LFS	
053 13 23 43 73 46 410	053 13 23 43 73	13 23 43 72 73	52 53 81 102 103	52 102			Characteristics a
		152 202	121 201 152 202 153 203 301 352 353	152 202	103 153 203		Characteristics b
		352 502	502 702	302	353 503	502 601 701M 702	Characteristics c
						801 12K1 15K1 20K1 25K1 30K1 37K1 11K1M 15K1M 22K1M 30K1M 37K1M 11K2 15K2 22K2 30K2 37K2	Characteristics d



# 4. CHARACTERISTICS

Servo motor							Graph of overload protection characteristics
HC-KFS	HC-MFS	HC-UFS	HC-SFS	HC-LFS	HC-RFS	HA-LFS	
			524 1024				Characteristics a
			1524 2024 3524				Characteristics b
			5024 7024			6014 701M4	Characteristics c
						8014 12K14 15K14 20K14 25K14 30K14 37K14 11K1M4 15K1M4 22K1M4 30K1M4 37K1M4 45K1M4 11K24 15K24 22K24 30K24 37K24 45K24	Characteristics d
						50K1M4 55K24	Characteristics e

The following graphs show overload protection characteristics.

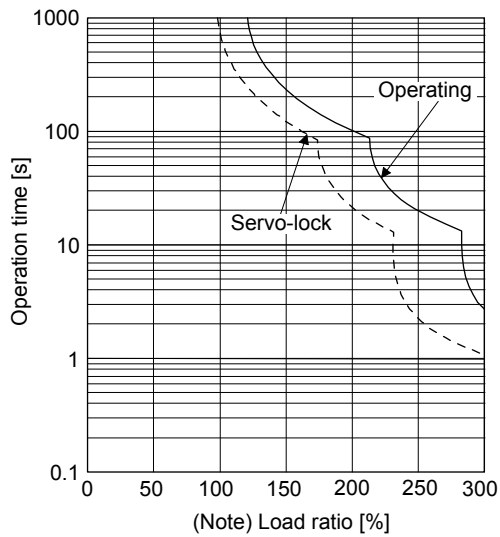

Characteristics a

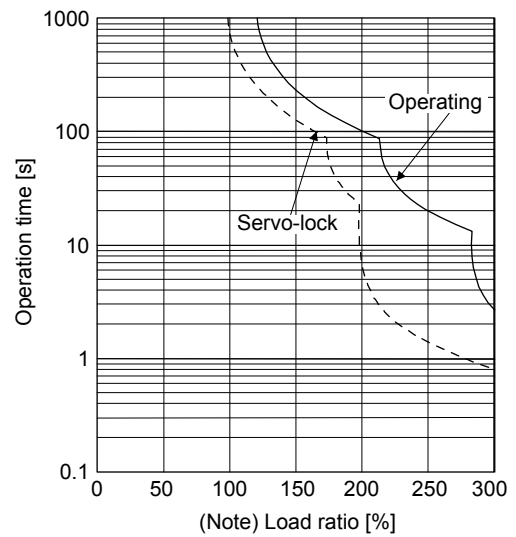

Characteristics b

# 4. CHARACTERISTICS

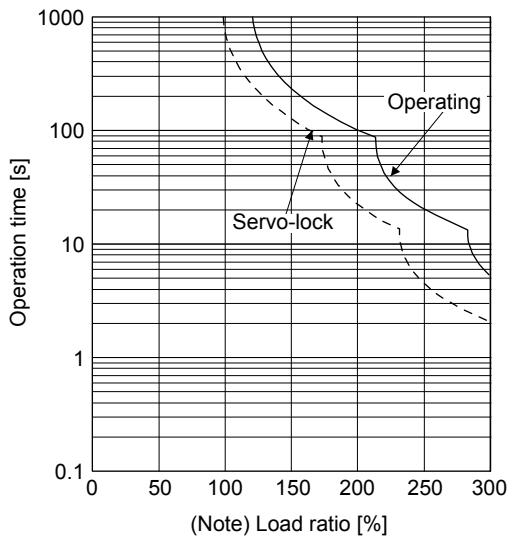

Characteristics c

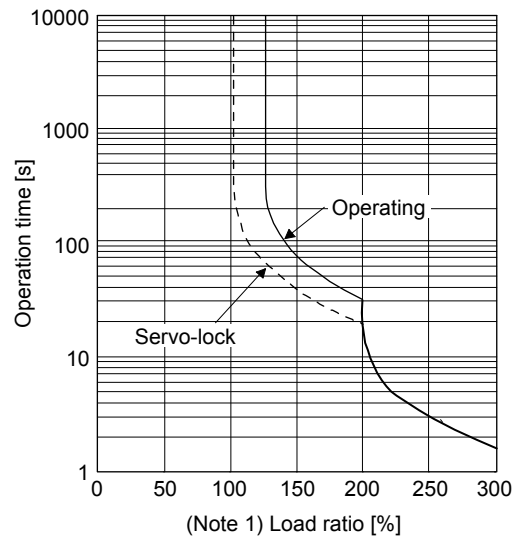

Characteristics d

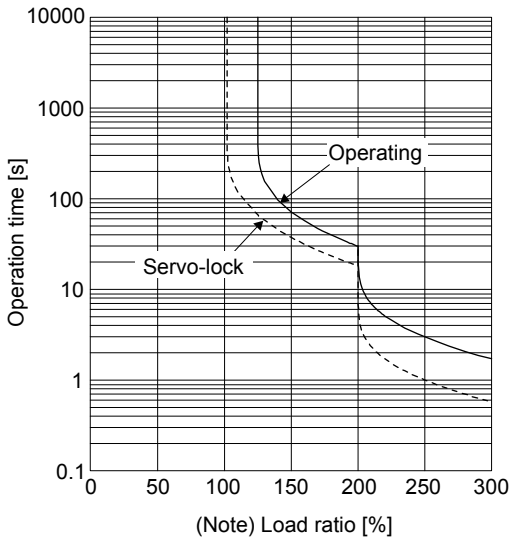

Characteristics e

Note. If operation that generates torque more than 100% of the rating is performed with an abnormally high frequency in a servo motor stop status (servo-lock status) or in a 30 r/min or less low-speed operation status, the servo amplifier may malfunction regardless of the electronic thermal protection.

Fig. 4.1 Electronic thermal protection characteristics

## 4. CHARACTERISTICS

### 4.2 Power supply capacity and generated loss

#### (1) Amount of heat generated by the servo amplifier

Table 4.1 indicates servo amplifiers' power supply capacities and losses generated under rated load. For thermal design of an enclosed type cabinet, use the values in the table in consideration for the worst operating conditions. The actual amount of generated heat will be intermediate between values at rated torque and servo-off according to the duty used during operation. When the servo motor is run at less than the rated speed, the power supply capacity will be smaller than the value in the table, but the servo amplifier's generated heat will not change.

Table 4.1 Power supply capacity and generated loss per servo motor at rated output

Servo amplifier	Servo motor	(Note 1) Power supply capacity [kVA]	(Note 2) Servo amplifier-generated heat [W]			Area required for heat dissipation [m <sup>2</sup> ]
			At rated output	At rated output [Generated heat in the cabinet when cooled outside the cabinet] (Note 3)	With servo-off	
MR-J4-10B-RJ020	HC-KFS053	0.3	25		15	0.5
	HC-KFS13	0.3	25		15	0.5
	HC-MFS053	0.3	25		15	0.5
	HC-MFS13	0.3	25		15	0.5
	HC-UFS13	0.3	25		15	0.5
MR-J4-20B-RJ020	HC-KFS23	0.5	25		15	0.5
	HC-MFS23	0.5	25		15	0.5
	HC-UFS23	0.5	25		15	0.5
MR-J4-40B-RJ020	HC-KFS43	0.9	35		15	0.7
	HC-MFS43	0.9	35		15	0.7
	HC-UFS43	0.9	35		15	0.7
MR-J4-60B-RJ020	HC-SFS52	1.0	40		15	0.8
	HC-SFS53	1.0	40		15	0.8
	HC-LFS52	1.0	40		15	0.8
MR-J4-70B-RJ020	HC-KFS73	1.3	50		15	1.0
	HC-KFS46	0.9	40		15	0.8
	HC-KFS410	0.9	40		15	0.8
	HC-MFS73	1.3	50		15	1.0
	HC-UFS72	1.3	50		15	1.0
MR-J4-100B-RJ020	HC-UFS73	1.3	50		15	1.0
	HC-SFS81	1.5	50	15	1.0	
	HC-SFS102	1.7	50	15	1.0	
	HC-SFS103	1.7	50	15	1.0	
MR-J4-200B-RJ020	HC-LFS102	1.7	50	15	1.0	
	HC-SFS121	2.1	90	20	1.8	
	HC-SFS201	3.5	90	20	1.8	
	HC-SFS152	2.5	90	20	1.8	
	HC-SFS202	3.5	90	20	1.8	
	HC-SFS153	2.5	90	20	1.8	
	HC-SFS203	3.5	90	20	1.8	
	HC-RFS103	1.8	50	15	1.0	
	HC-RFS153	2.5	90	20	1.8	
	HC-UFS152	2.5	90	20	1.8	
MR-J4-350B-RJ020	HC-LFS152	2.5	90	20	1.8	
	HC-SFS301	4.8	120	20	2.7	
	HC-SFS352	5.5	130	20	2.7	
	HC-SFS353	5.5	130	20	2.7	
	HC-RFS203	3.5	90	20	1.8	
	HC-UFS202	3.5	90	20	1.8	
	HC-LFS202	3.5	90	20	1.8	

## 4. CHARACTERISTICS

Servo amplifier	Servo motor	(Note 1) Power supply capacity [kVA]	(Note 2) Servo amplifier-generated heat [W]			Area required for heat dissipation [m <sup>2</sup> ]	
			At rated output	At rated output [Generated heat in the cabinet when cooled outside the cabinet] (Note 3)	With servo-off		
MR-J4-500B-RJ020	HC-SFS502	7.5	195		25	3.9	
	HC-RFS353	5.5	135		25	2.7	
	HC-RFS503	7.5	195		25	3.9	
	HC-UFS352	5.5	195		25	3.9	
	HC-UFS502	7.5	195		25	3.9	
	HA-LFS502	7.5	195		25	3.9	
	HC-LFS302	4.5	120		25	2.4	
MR-J4-700B-RJ020	HC-SFS702	10	300	25	6.0		
	HA-LFS601	8.6	300	25	6.0		
	HA-LFS701M	10	300	25	6.0		
	HA-LFS702	10.6	300	25	6.0		
MR-J4-11KB-RJ020	HA-LFS801	12	390	120	45	7.8	
	HA-LFS11K1M	16	530	160	45	11.0	
	HA-LFS11K2	16	530	160	45	11.0	
	HA-LFS12K1	18	580	175	45	11.6	
MR-J4-15KB-RJ020	HA-LFS15K1	22	640	195	45	13.0	
	HA-LFS15K1M	22	640	195	45	13.0	
	HA-LFS15K2	22	640	195	45	13.0	
MR-J4-22KB-RJ020	HA-LFS20K1	30	775	235	55	15.5	
	HA-LFS22K1M	33	850	260	55	17.0	
	HA-LFS22K2	33	850	260	55	17.0	
	HA-LFS25K1	38	970	295	55	19.4	
MR-J4-60B4-RJ020	HC-SFS524	1.0	40		15	0.8	
MR-J4-100B4-RJ020	HC-SFS1024	1.7	50		15	1.0	
MR-J4-200B4-RJ020	HC-SFS1524	2.5	90		20	1.8	
	HC-SFS2024	3.5	90		20	1.8	
MR-J4-350B4-RJ020	HC-SFS3524	5.5	130		20	2.7	
MR-J4-500B4-RJ020	HC-SFS5024	7.5	195		25	3.9	
MR-J4-700B4-RJ020	HC-SFS7024	10	300		25	6.0	
	HA-LFS6014	8.6	300		25	6.0	
	HA-LFS701M4	10	300		25	6.0	
MR-J4-11KB4-RJ020	HA-LFS8014	12	390		120	45	7.8
	HA-LFS11K1M4	16	530		160	45	11.0
	HA-LFS11K24	16	530		160	45	11.0
	HA-LFS12K14	18	580		175	45	11.6
MR-J4-15KB4-RJ020	HA-LFS15K14	22	640		195	45	13.0
	HA-LFS15K1M4	22	640	195	45	13.0	
	HA-LFS15K24	22	640	195	45	13.0	
MR-J4-22KB4-RJ020	HA-LFS20K14	30	775	235	55	15.5	
	HA-LFS22K1M4	33	850	260	55	17.0	
	HA-LFS22K24	33	850	260	55	17.0	
MR-J4-10B1-RJ020	HC-KFS053	0.3	25		15	0.5	
	HC-KFS13	0.3	25		15	0.5	
	HC-MFS053	0.3	25		15	0.5	
	HC-MFS13	0.3	25		15	0.5	
	HC-UFS13	0.3	25		15	0.5	
MR-J4-20B1-RJ020	HC-KFS23	0.5	25		15	0.5	
	HC-MFS23	0.5	25		15	0.5	
	HC-UFS23	0.5	25		15	0.5	
MR-J4-40B1-RJ020	HC-KFS43	0.9	35		15	0.7	
	HC-MFS43	0.9	35		15	0.7	
	HC-UFS43	0.9	35		15	0.7	

## 4. CHARACTERISTICS

- Note
- Note that the power supply capacity will vary according to the power supply impedance. This value is applicable when the power factor improving AC reactor or power factor improving DC reactor is not used.
  - Heat generated during regeneration is not included in the servo amplifier-generated heat. To calculate heat generated by the regenerative option, refer to section 5.4.
  - This value is applicable when the servo amplifier is cooled by using the panel through attachment.

### (2) Generated heat of the converter unit/drive unit

Table 4.1 indicates the generated loss and power supply capacity under rated load per combination of the converter unit and drive unit. When the servo motors are run at less than the rated speed, the power supply equipment capacity is lower than the value in the table but the heat generated does not change. Since the servo motor requires 2 times to 2.5 times greater instantaneous power for acceleration, use the power supply which ensures that the voltage lies within the permissible voltage fluctuation at the main circuit power supply terminals (L1, L2, and L3) of the converter unit. The power supply equipment capacity changes with the power supply impedance.

The actually generated heat falls within the ranges at rated output and at servo-off according to the frequencies of use during operation. When designing an enclosed cabinet, use the values in the table, considering the worst operating conditions. The generated heat in table 4.1 does not include heat produced during regeneration.

Table 4.2 Power supply capacity and generated heat per servo motor at rated output

Converter unit	Drive unit	Servo motor	Power supply capacity [kVA]		(Note) Drive unit-generated heat [W]			Area required for heat dissipation [m <sup>2</sup> ]
			Power factor improving DC reactor is not used	Power factor improving DC reactor is used	At rated output	At rated output [Generated heat in the cabinet when cooled outside the cabinet]	At servo-off	
MR-CR55K	MR-J4-DU30KB-RJ020	HA-LFS30K1 HA-LFS30K1M HA-LFS30K2	48	40	1550 (1100 + 450)	470	60 (30 + 30)	31.0
	MR-J4-DU37KB-RJ020	HA-LFS37K1 HA-LFS37K1M HA-LFS37K2	59	49	1830 (1280 + 550)	550		36.6
MR-CR55K4	MR-J4-DU30KB4-RJ020	HA-LFS25K14	40	35	1080 (850 + 230)	330		21.6
		HA-LFS30K14 HA-LFS30K1M4 HA-LFS30K24	48	40	1290 (1010 + 280)	390		25.8
	MR-J4-DU37KB4-RJ020	HA-LFS37K14 HA-LFS37K1M4 HA-LFS37K24	59	49	1542 (1200 + 342)	470		30.8
	MR-J4-DU45KB4-RJ020	HA-LFS45K1M4 HA-LFS45K24	71	59	1810 (1370 + 440)	550		36.2
	MR-J4-DU55KB4-RJ020	HA-LFS50K1M4	80	67	2120 (1650 + 470)	640	42.4	
		HA-LFS55K24	87	72	2150 (1650 + 500)	650	43.0	

Note. The heat generated by the drive unit is indicated in the left term within the parentheses, and the heat generated by the converter unit in the right term.

## 4. CHARACTERISTICS

---

(2) Heat dissipation area for an enclosed type cabinet

The enclosed type cabinet (hereafter called the cabinet) which will contain the servo amplifier should be designed to ensure that its temperature rise is within +10 °C at the ambient temperature of 40 °C. (With an approximately 5 °C safety margin, the system should operate within a maximum 55 °C limit.) The necessary cabinet heat dissipation area can be calculated by equation 4.1.

$$A = \frac{P}{K \cdot \Delta T} \dots\dots\dots (4.1)$$

A: Heat dissipation area [m<sup>2</sup>]

P: Loss generated in the cabinet [W]

ΔT: Difference between internal and ambient temperatures [°C]

K: Heat dissipation coefficient [5 to 6]

When calculating the heat dissipation area with equation 4.1, assume that P is the sum of all losses generated in the cabinet. Refer to table 4.1 for heat generated by the servo amplifier. "A" indicates the effective area for heat dissipation, but if the cabinet is directly installed on an insulated wall, that extra amount must be added to the cabinet's surface area. The required heat dissipation area will vary with the conditions in the cabinet. If convection in the cabinet is poor and heat builds up, effective heat dissipation will not be possible. Therefore, arrangement of the equipment in the cabinet and the use of a cooling fan should be considered. Table 4.1 lists the cabinet dissipation area for each servo amplifier (guideline) when the servo amplifier is operated at the ambient temperature of 40 °C under rated load.

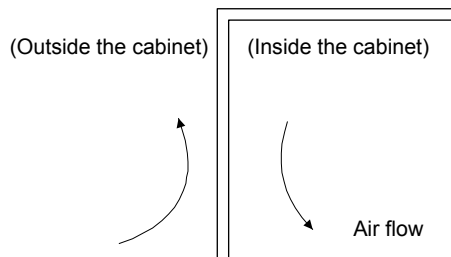

Fig. 4.2 Temperature distribution in an enclosed type cabinet

When air flows along the outer wall of the cabinet, effective heat exchange will be possible, because the temperature slope inside and outside the cabinet will be steeper.

# 4. CHARACTERISTICS

## 4.3 Dynamic brake characteristics

POINT
<ul style="list-style-type: none"> <li>● Do not use dynamic brake to stop in a normal operation as it is the function to stop in emergency.</li> <li>● For a machine operating at the recommended load to motor inertia ratio or less, the estimated number of usage times of the dynamic brake is 1000 times while the machine decelerates from the rated speed to a stop once in 10 minutes.</li> <li>● Be sure to enable EM1 (Forced stop) after servo motor stops when using EM1 (Forced stop) frequently in other than emergency.</li> <li>● For the servo amplifier of 7 kW or less, the dynamic brake characteristics in this section are different from those of MR-J2S-_B_ servo amplifier.</li> <li>● When an HA series servo motor is used with the servo amplifier of 11 kW or more, use the external dynamic brake for MR-J2S. The external dynamic brake for MR-J4 cannot be used.</li> </ul>

### (1) Dynamic brake operation

#### (a) Calculation of coasting distance

Fig. 4.3 shows the pattern in which the servo motor comes to a stop when the dynamic brake is operated. Use equation 4.2 to calculate an approximate coasting distance to a stop. The dynamic brake time constant  $\tau$  varies with the servo motor and machine operation speeds. (Refer to (1) (b) of this section.)

A working part generally has a friction force. Therefore, actual coasting distance will be shorter than a maximum coasting distance calculated with the following equation.

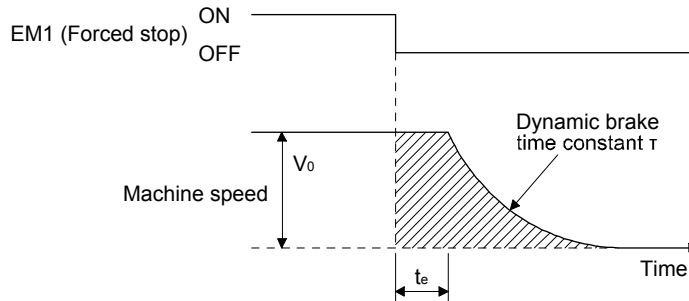

Fig. 4.3 Dynamic brake operation diagram

$$L_{\max} = \frac{V_0}{60} \cdot \left\{ t_e + \tau \left( 1 + \frac{J_L}{J_M} \right) \right\} \dots \dots \dots (4.2)$$

- $L_{\max}$  : Maximum coasting distance ..... [mm]
- $V_0$  : Machine's fast feed speed ..... [mm/min]
- $J_M$  : Moment of inertia of the servo motor ..... [ $\times 10^{-4}$  kg·m<sup>2</sup>]
- $J_L$  : Load moment of inertia converted into equivalent value on servo motor shaft ..... [ $\times 10^{-4}$  kg·m<sup>2</sup>]
- $\tau$  : Dynamic brake time constant ..... [s]
- $t_e$  : Delay time of control section ..... [s]

For 7 kW or lower servo, there is internal relay delay time of about 10 ms. For 11 kW or more servo, there is delay caused by magnetic contactor built into the external dynamic brake (about 50 ms) and delay caused by the external relay.

# 4. CHARACTERISTICS

## (b) Dynamic brake time constant

The following shows necessary dynamic brake time constant  $\tau$  for equation 4.2.

### 1) 200 V class

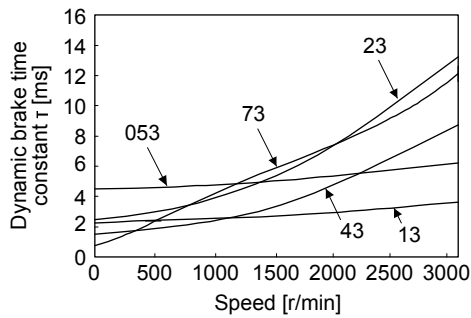

HC-KFS 3000 r/min series

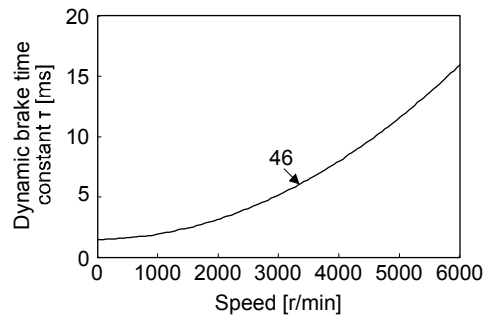

HC-KFS 6000 r/min series

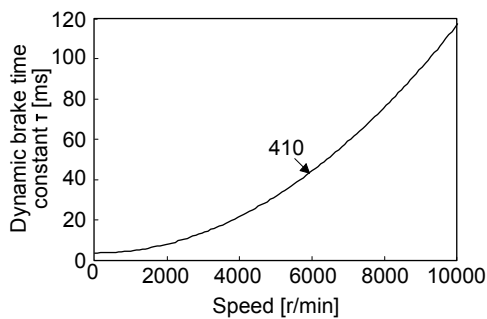

HC-KFS 10000 r/min series

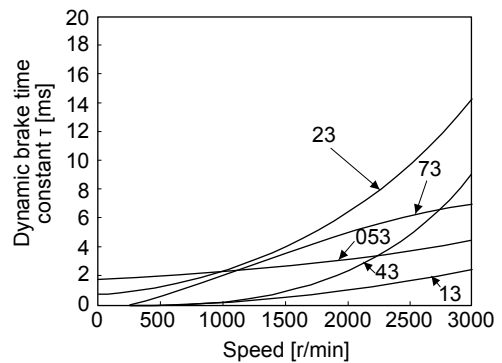

HC-MFS series

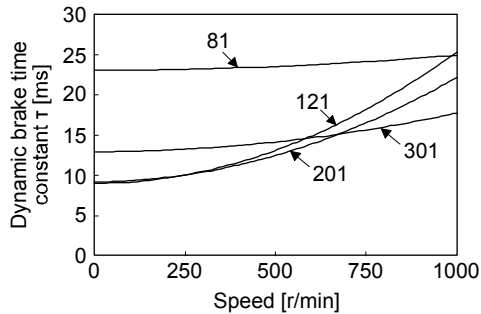

HC-SFS 1000 r/min series

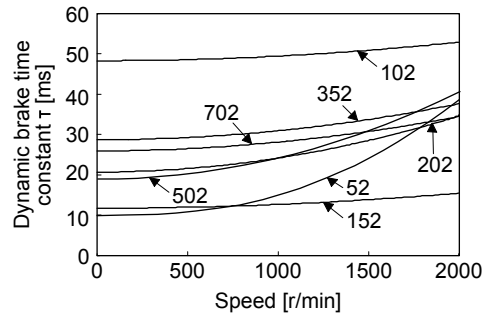

HC-SFS 2000 r/min series

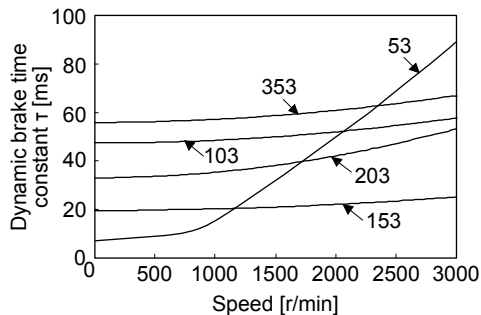

HC-SFS 3000 r/min series

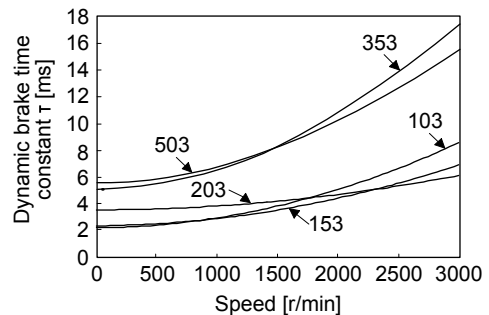

HC-RFS series



# 4. CHARACTERISTICS

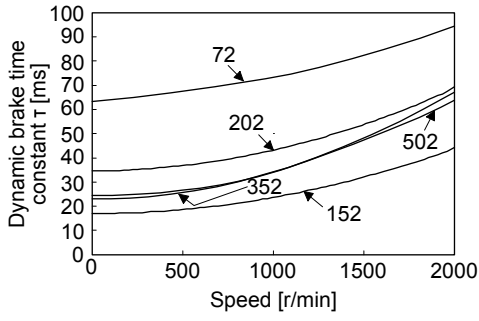

HC-UFS 2000 r/min series

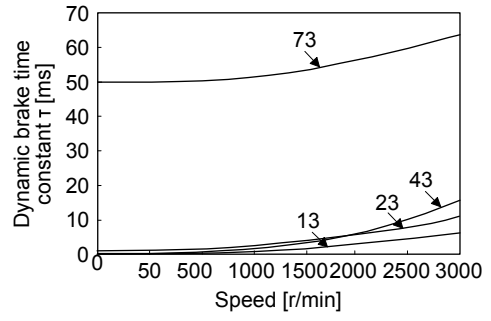

HC-UFS 3000 r/min series

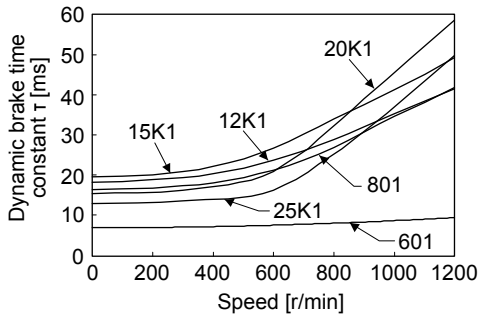

HA-LFS 1000 r/min series

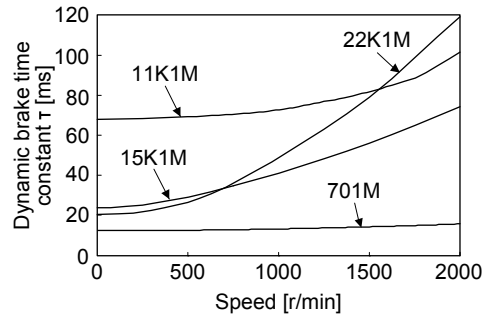

HA-LFS 1500 r/min series

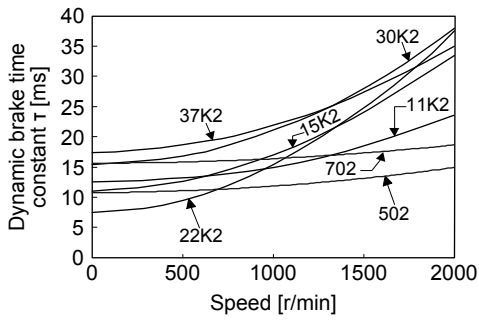

HA-LFS 2000 r/min series

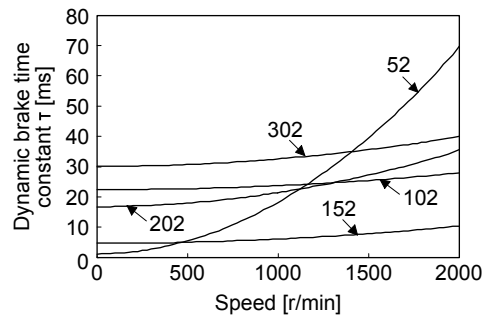

HC-LFS series

# 4. CHARACTERISTICS

## 2) 400 V class

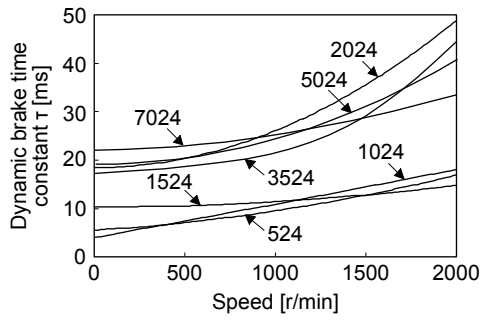

HC-SFS series

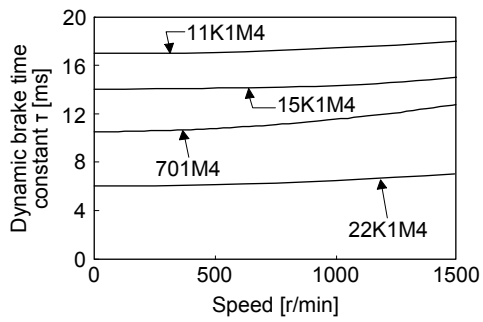

HA-LFS 1500 r/min series

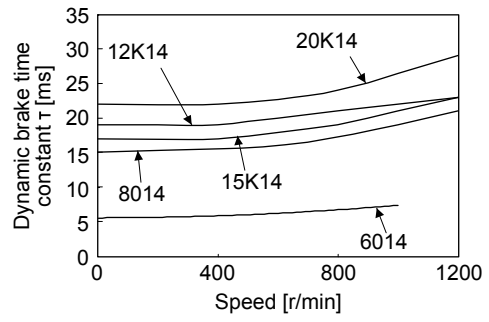

HA-LFS 1000 r/min series

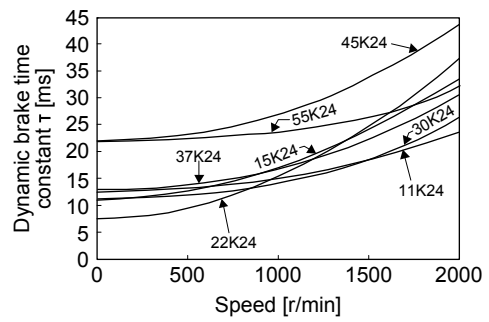

HA-LFS 2000 r/min series

## 4. CHARACTERISTICS

(2) Permissible load to motor inertia when the dynamic brake is used

Use the dynamic brake under the load to motor inertia ratio indicated in the following table. If the ratio is higher than this value, the dynamic brake may burn. If there is a possibility that the ratio may exceed the value, contact your local sales office.

The values of the permissible load to motor inertia ratio in the table are the values at the maximum rotation speed of the servo motor.

Servo motor	Permissible load to motor inertia ratio [multiplier]
HC-KFS053	30
HC-KFS13	
HC-KFS23	
HC-KFS43	
HC-KFS73	
HC-KFS46	
HC-KFS410	
HC-MFS053	
HC-MFS13	
HC-MFS23	
HC-MFS43	
HC-MFS73	
HC-SFS52	
HC-SFS53	
HC-SFS81	
HC-SFS102	
HC-SFS103	
HC-SFS121	
HC-SFS201	
HC-SFS152	
HC-SFS202	
HC-SFS153	
HC-SFS203	
HC-SFS301	16
HC-SFS352	
HC-SFS353	
HC-SFS502	15
HC-SFS702	
HC-SFS524	30
HC-SFS1024	
HC-SFS1524	
HC-SFS2024	16
HC-SFS3524	
HC-SFS5024	15
HC-SFS7024	
HC-RFS103	30
HC-RFS153	
HC-RFS203	16
HC-RFS353	
HC-RFS503	15
HC-UFS13	
HC-UFS23	30
HC-UFS43	
HC-UFS72	
HC-UFS73	
HC-UFS152	16
HC-UFS202	

Servo motor	Permissible load to motor inertia ratio [multiplier]
HC-UFS352	15
HC-UFS502	
HA-LFS502	
HA-LFS601	
HA-LFS701M	
HA-LFS702	
HA-LFS801	
HA-LFS11K1M	
HA-LFS11K2	
HA-LFS12K1	
HA-LFS15K1	
HA-LFS15K1M	
HA-LFS15K2	
HA-LFS20K1	
HA-LFS22K1M	
HA-LFS22K2	
HA-LFS25K1	15
HA-LFS6014	
HA-LFS701M4	30
HA-LFS8014	
HA-LFS11K1M4	
HA-LFS11K24	
HA-LFS12K14	
HA-LFS15K14	
HA-LFS15K1M4	
HA-LFS15K24	
HA-LFS20K14	
HA-LFS22K1M4	
HA-LFS22K24	10
HA-LFS30K2	
HA-LFS37K2	
HA-LFS30K24	
HA-LFS37K24	
HA-LFS45K24	
HA-LFS55K24	30
HC-LFS52	
HC-LFS102	
HC-LFS152	16
HC-LFS202	
HC-LFS302	15

## 4. CHARACTERISTICS

---

### 4.4 Cable bending life

The bending life of the cables is shown below. This graph calculated values. Since they are not guaranteed values, provide a little allowance for these values.

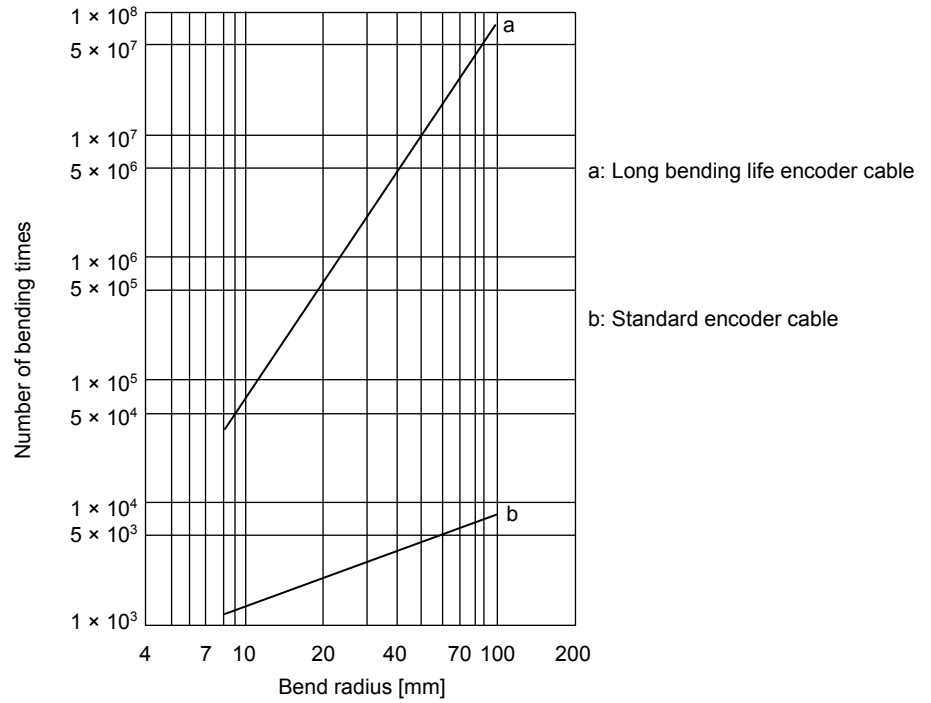

## 4. CHARACTERISTICS

### 4.5 Inrush currents at power-on of main circuit and control circuit

POINT
<ul style="list-style-type: none"> <li>● The inrush current values can change depending on frequency of turning on/off the power and ambient temperature.</li> </ul>

Since large inrush currents flow in the power supplies, always use molded-case circuit breakers and magnetic contactors. (Refer to "MR-J4-(DU)\_B\_-RJ020 MR-J4-T20 Servo Amplifier Instruction Manual" section 11.10 or 14.9.5.)

When circuit protectors are used, it is recommended that the inertia delay type, which is not tripped by an inrush current, be used.

#### 4.5.1 Inrush current of servo amplifier

##### (1) 200 V class

The following table indicates the inrush currents (reference data) that will flow when 240 V AC is applied at the power supply capacity of 2500 kVA and the wiring length of 1 m. Even when you use a 1-phase 200 V AC power supply with MR-J4-10B-RJ020 to MR-J4-70B-RJ020, the inrush currents of the main circuit power supply will be the same.

Servo amplifier	Inrush currents ( $A_{0-P}$ )	
	Main circuit power supply (L1, L2, and L3)	Control circuit power supply (L11 and L21)
MR-J4-10B-RJ020 MR-J4-20B-RJ020 MR-J4-40B-RJ020 MR-J4-60B-RJ020	30 A (attenuated to approx. 3 A in 20 ms)	20 A to 30 A (attenuated to approx. 1 A in 20 ms)
MR-J4-70B-RJ020 MR-J4-100B-RJ020	34 A (attenuated to approx. 7 A in 20 ms)	
MR-J4-200B-RJ020 MR-J4-350B-RJ020	113 A (attenuated to approx. 12 A in 20 ms)	
MR-J4-500B-RJ020	42 A (attenuated to approx. 20 A in 20 ms)	34 A (attenuated to approx. 2 A in 20 ms)
MR-J4-700B-RJ020	85 A (attenuated to approx. 20 A in 30 ms)	
MR-J4-11KB-RJ020	226 A (attenuated to approx. 30 A in 30 ms)	42 A (attenuated to approx. 2 A in 30 ms)
MR-J4-15KB-RJ020	226 A (attenuated to approx. 50 A in 30 ms)	
MR-J4-22KB-RJ020	226 A (attenuated to approx. 70 A in 30 ms)	

## 4. CHARACTERISTICS

### (2) 400 V class

The following table indicates the inrush currents (reference data) that will flow when 480 V AC is applied at the power supply capacity of 2500 kVA and the wiring length of 1 m.

Servo amplifier	Inrush currents ( $A_{0-P}$ )	
	Main circuit power supply (L1, L2, and L3)	Control circuit power supply (L11 and L21)
MR-J4-60B4-RJ020 MR-J4-100B4-RJ020	65 A (attenuated to approx. 5 A in 10 ms)	40 A to 50 A (attenuated to approx. 0 A in 2 ms)
MR-J4-200B4-RJ020	80 A (attenuated to approx. 5 A in 10 ms)	
MR-J4-350B4-RJ020	100 A (attenuated to approx. 20 A in 10 ms)	
MR-J4-500B4-RJ020	65 A (attenuated to approx. 9 A in 20 ms)	41 A (attenuated to approx. 0 A in 3 ms)
MR-J4-700B4-RJ020	68 A (attenuated to approx. 34 A in 20 ms)	
MR-J4-11KB4-RJ020	339 A (attenuated to approx. 10 A in 30 ms)	38 A (attenuated to approx. 1 A in 30 ms)
MR-J4-15KB4-RJ020	339 A (attenuated to approx. 15 A in 30 ms)	
MR-J4-22KB4-RJ020	339 A (attenuated to approx. 20 A in 30 ms)	

### (3) 100 V class

The following table indicates the inrush currents (reference data) that will flow when 120 V AC is applied at the power supply capacity of 2500 kVA and the wiring length of 1 m.

Servo amplifier	Inrush currents ( $A_{0-P}$ )	
	Main circuit power supply (L1/L2)	Control circuit power supply (L11/L21)
MR-J4-10B1-RJ020 MR-J4-20B1-RJ020 MR-J4-40B1-RJ020	38 A (attenuated to approx. 14 A in 10 ms)	20 A to 30 A (attenuated to approx. 0 A in 1 ms to 2 ms)

## 4. CHARACTERISTICS

### 4.5.2 Inrush current of converter unit/drive unit

#### (1) 200 V class

The following table indicates the inrush currents (reference data) that will flow when 240 V AC is applied at the power supply capacity of 2500 kVA and the wiring length of 1 m.

##### (a) Converter unit

Converter unit	Inrush currents ( $A_{0-P}$ )	
	Main circuit power supply (L1, L2, and L3)	Control circuit power supply (L11 and L21)
MR-CR55K	154 A (Attenuated to approx. 20 A in 150 ms)	31 A (attenuated to approx. 2 A in 60 ms)

##### (b) Drive unit

Drive unit	Inrush currents ( $A_{0-P}$ )
	Control circuit power supply (L11 and L21)
MR-J4-DU30KB-RJ020	31 A (attenuated to approx. 2 A in 60 ms)
MR-J4-DU37KB-RJ020	

#### (2) 400 V class

The following table indicates the inrush currents (reference data) that will flow when 480 V AC is applied at the power supply capacity of 2500 kVA and the wiring length of 1 m.

##### (a) Converter unit

Converter unit	Inrush currents ( $A_{0-P}$ )	
	Main circuit power supply (L1, L2, and L3)	Control circuit power supply (L11 and L21)
MR-CR55K4	305 A (attenuated to approx. 20 A in 70 ms)	27 A (attenuated to approx. 2 A in 45 ms)

##### (b) Drive unit

Drive unit	Inrush currents ( $A_{0-P}$ )
	Control circuit power supply (L11 and L21)
MR-J4-DU30KB4-RJ020	27 A (attenuated to approx. 2 A in 45 ms)
MR-J4-DU37KB4-RJ020	
MR-J4-DU45KB4-RJ020	
MR-J4-DU55KB4-RJ020	

## 5. OPTIONS AND PERIPHERAL EQUIPMENT

---

### 5. OPTIONS AND PERIPHERAL EQUIPMENT

#### WARNING

- Before connecting any option or peripheral equipment, turn off the power and wait for 15 minutes or more (20 minutes or more for 30 kW or more) until the charge lamp turns off. Then, confirm that the voltage between P+ and N- (L+ and L- for 30 kW or more) is safe with a voltage tester and others. Otherwise, an electric shock may occur. In addition, when confirming whether the charge lamp is off or not, always confirm it from the front of the servo amplifier.

#### CAUTION

- Use the specified peripheral equipment and options to prevent a malfunction or a fire.

This chapter describes only encoder cables and regenerative options for connecting HC/HA series servo motors to an MR-J4-\_B\_-RJ020 servo amplifier. For options for the servo amplifier, refer to chapter 11 and 14 of "MR-J4-(DU)\_B\_-RJ020 MR-J4-T20 Servo Amplifier Instruction Manual". For options for the HC/HA series servo motor, refer to "MR-J2S-\_B Servo Amplifier Instruction Manual (SH(NA)030007)" and "Servo Motor Instruction Manual (SH(NA)3181)".

#### POINT

- The IP rating indicated for cables and connectors is their protection against ingress of dust and raindrops when they are connected to a servo amplifier or servo motor. If the IP rating of the cable, connector, servo amplifier and servo motor vary, the overall IP rating depends on the lowest IP rating of all components.

Please purchase the cable and connector options indicated in this section.







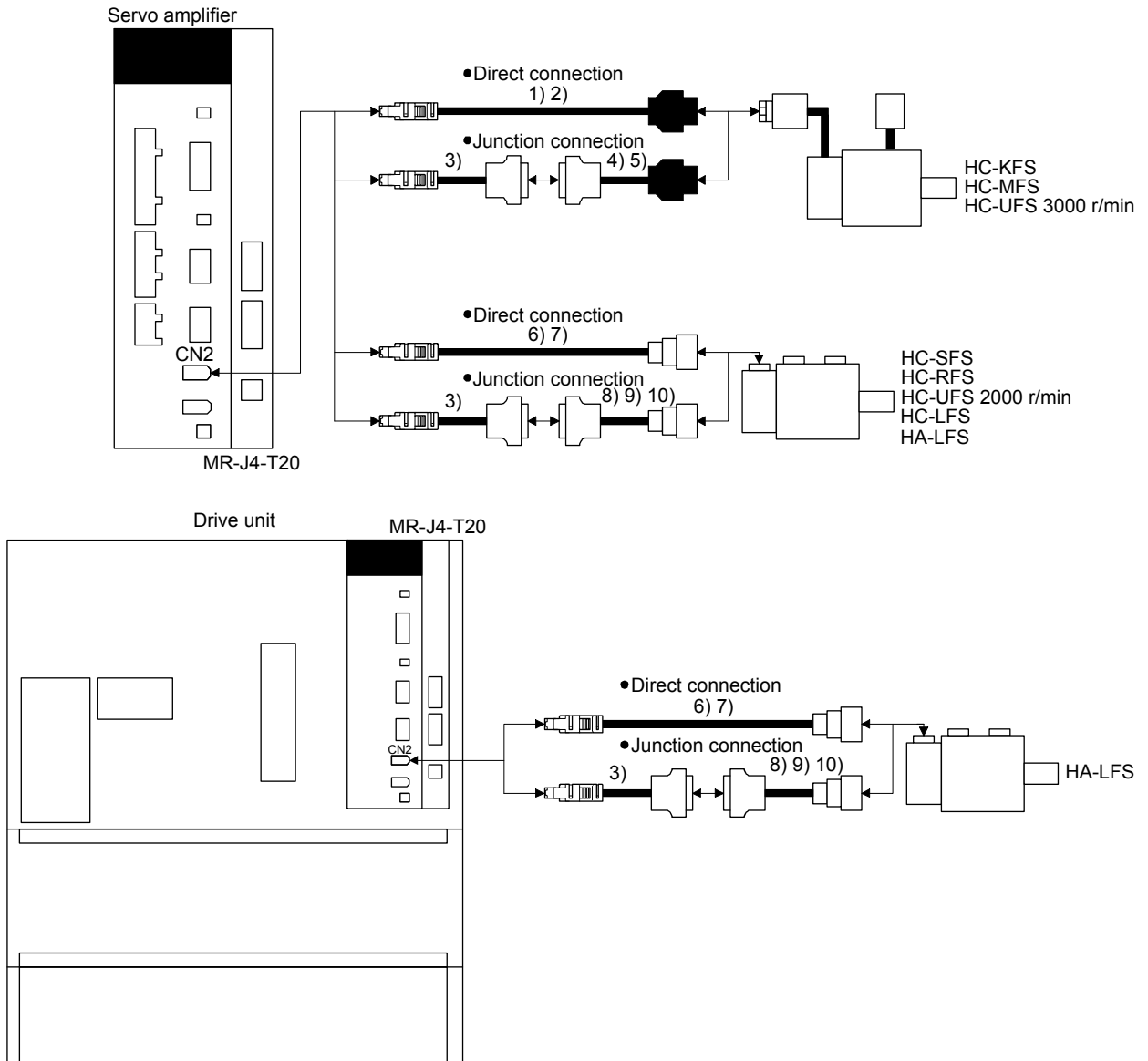

# 5. OPTIONS AND PERIPHERAL EQUIPMENT

## 5.1 Combinations of encoder cables



## 5. OPTIONS AND PERIPHERAL EQUIPMENT

### 5.2 Encoder cable list

No.	Product name	Model	Description	Remark	
1)	Encoder cable	MR-EKCBL_M-L Cable length: 20/30 m	 Refer to section 5.3 (1) for details.	IP20	
2)	Encoder cable	MR-EKCBL_M-H Cable length: 20/30/40/50 m		IP20 Long bending life	
3)	Encoder cable	MR-J3CH00 Cable length: 0.2 m	 Refer to section 5.3 (2) for details.	IP20	
4)	Encoder cable	MR-JCCBL_M-L Cable length: 2/5/10/20/30 m	Connector: 10120-3000PE Shell kit: 10320-52F0-008 (3M or equivalent)	Housing: 1-172161-9 Connector pin: 170359-1 (TE Connectivity or equivalent) Cable clamp: MTI-0002 (Toa Electric Industrial)	IP20
5)	Encoder cable	MR-JCCBL_M-H Cable length: 2/5/10/20/30/40/50 m		IP20 Long bending life	
6)	Encoder cable	MR-ESCBL_M-L Cable length: 2/5/10/20/30 m	 Refer to section 5.3 (3) for details.	IP20	
7)	Encoder cable	MR-ESCBL_M-H Cable length: 2/5/10/20/30/40/50 m		IP20 Long bending life	
8)	Encoder cable	MR-JHSCBL_M-L Cable length: 2/5/10/20/30 m	Connector: 10120-3000PE Shell kit: 10320-52F0-008 (3M or equivalent)	Plug: D/MS3106B20-29S Cable clamp: D/MS3057-12A (DDK)	IP20
9)	Encoder cable	MR-JHSCBL_M-H Cable length: 2/5/10/20/30/40/50 m		IP20 Long bending life	
10)	Encoder cable	MR-ENCBL_M-H Cable length: 2/5/10/20/30/40/50 m	Connector: 10120-3000PE Shell kit: 10320-52F0-008 (3M or equivalent)	Plug: D/MS3106A20-29S(D190) Cable clamp: CE3057-12A-3-D Backshell: CE02-20BS-S-D (DDK)	IP65 Long bending life
					

## 5. OPTIONS AND PERIPHERAL EQUIPMENT

### 5.3 Detail of the encoder cable

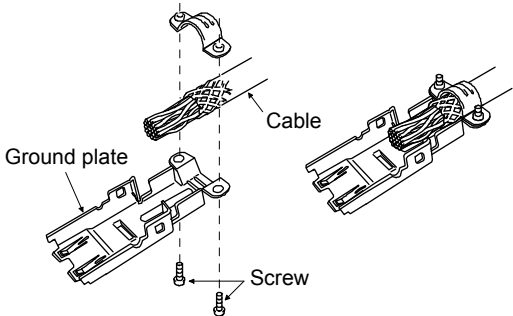
POINT
<p>● For the CN2 side connector, securely connect the shielded external conductor of the cable to the ground plate and fix it to the connector shell.</p>  <p>● The following encoder cables are of four-wire type.</p> <p>MR-EKCBL30M-L            MR-EKCBL30M-H            MR-EKCBL40M-H            MR-EKCBL50M-H            MR-ESCBL30M-L            MR-ESCBL30M-H            MR-ESCBL40M-H            MR-ESCBL50M-H</p> <p>When using any of these encoder cables, set [Pr. 23] to "_ 1 _" to select "four-wire type".            Incorrect setting will trigger [AL. 16 Encoder error 1].</p>

(1) MR-EKCBL\_M\_

These cables are encoder cables for the HC-KFS, HC-MFS, and HC-UFS 3000 r/min series servo motors.

The numbers in the cable length field of the table indicate the symbol filling the underline "\_" in the cable model. The cables of the lengths with the symbols are available.

Cable model	Cable length				IP rating	Bending life	Application
	20 m	30 m	40 m	50 m			
MR-EKCBL_M-L	20	(Note) 30	/	/	IP20	Standard	HC-KFS, HC-MFS, and HC-UFS 3000 r/min series servo motors
MR-EKCBL_M-H	20	(Note) 30	(Note) 40	(Note) 50	IP20	Long bending life	

Note. Four-wire type cable

# 5. OPTIONS AND PERIPHERAL EQUIPMENT

(a) Connection of servo amplifier and servo motor

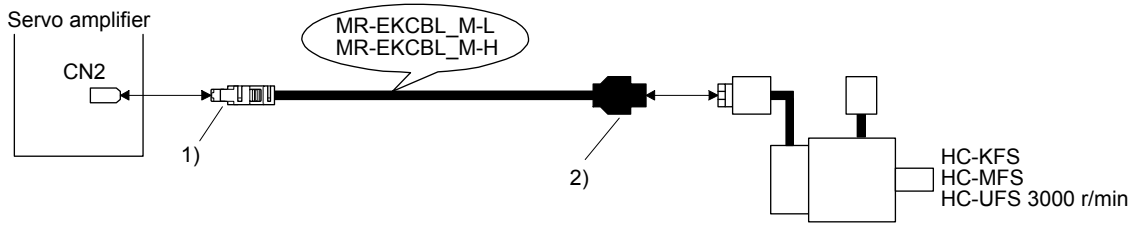

Cable model	1) CN2-side connector	2) Encoder-side connector
MR-EKCBL_M-L	<p>Receptacle: 36210-0100PL Shell kit: 36310-3200-008 (3M)</p> <p>View seen from the wiring side. (Note)</p>	<p>Housing: 1-172161-9 Connector pin: 170359-1 Crimping tool: 91529-1 (TE Connectivity or equivalent) Cable clamp: MTI-0002 (Toa Electric Industrial)</p>
MR-EKCBL_M-H	<p>Connector set: 54599-1019 (Molex)</p> <p>View seen from the wiring side. (Note)</p> <p>Note. Do not connect anything to the pins shown as . Especially, pin 10 is provided for manufacturer adjustment. If it is connected with any other pin, the servo amplifier cannot operate normally. Referring POINT of this section, securely connect the shielded cable external conductor of the shielded cable to the ground plate and fix it to the connector shell.</p>	<p>View seen from the wiring side.</p>

# 5. OPTIONS AND PERIPHERAL EQUIPMENT

(b) Cable internal wiring diagram

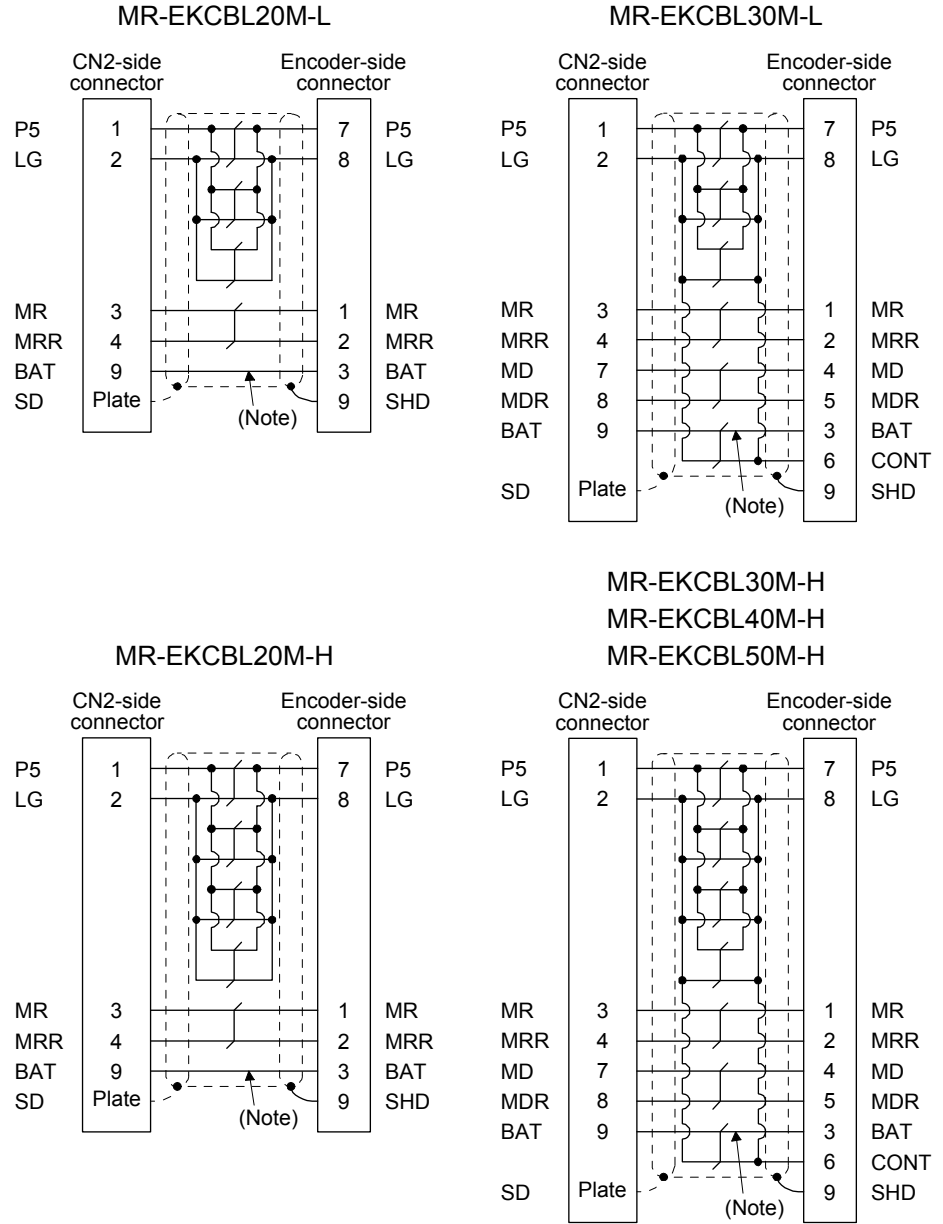

Note. Always make connection for use in an absolute position detection system. Wiring is not necessary for use in an incremental system.

## 5. OPTIONS AND PERIPHERAL EQUIPMENT

---

(2) MR-J3CH00

The servo amplifier and the servo motor cannot be connected by this cable alone. Use it with the following encoder cables.

MR-JCCBL\_M-L

MR-JCCBL\_M-H

MR-JHSCBL\_M-L

MR-JHSCBL\_M-H

MR-ENCBL\_M-H

Cable model	Cable length	IP rating	Bending life	Application
MR-J3CH00	0.2 m	IP20	Standard	HC-KFS, HC-MFS series, and HC-UFS 3000 r/min servo motors Use this in combination with MR-JCCBL_M-L/H.
				HC-SFS, HC-RFS, HA-LFS series, and HC-UFS 2000 r/min servo motors Use this in combination with MR-JHSCBL_M-L/H or MR-ENCBL_M-H.

# 5. OPTIONS AND PERIPHERAL EQUIPMENT

(a) Connection of servo amplifier and servo motor

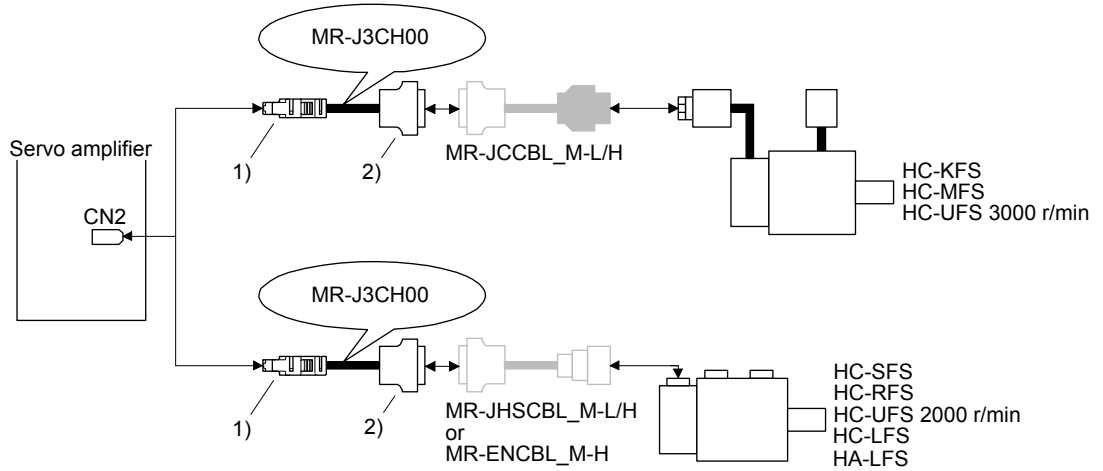

Cable model	1) CN2-side connector	2) Junction connector
MR-J3CH00	Receptacle: 36210-0100PL Shell kit: 36310-3200-008 (3M)  View seen from the wiring side. (Note)      View seen from the wiring side. (Note)	Connector: 10220-0200EL Shell kit: 10320-E2W0-008 (3M)  View seen from the wiring side. (Note)
	Note. Do not connect anything to the pins shown as . Especially, pin 10 is provided for manufacturer adjustment. If it is connected with any other pin, the servo amplifier cannot operate normally. Referring POINT of this section, securely connect the shielded cable external conductor of the shielded cable to the ground plate and fix it to the connector shell.	Note. Do not connect anything to the pins shown as .

## 5. OPTIONS AND PERIPHERAL EQUIPMENT

### (b) Cable internal wiring diagram

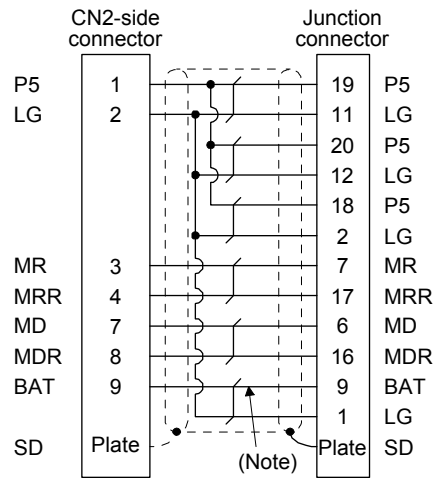

Note. Always make connection for use in an absolute position detection system. Wiring is not necessary for use in an incremental system.

### (3) MR-ESCBL\_M-

These encoder cables are for HC-SFS, HC-RFS, HC-LFS, HA-LFS series and HC-UFS 2000 r/min servo motors. The numbers in the cable length field of the table indicate the symbol filling the underline "\_" in the cable model. The cables of the lengths with the symbols are available.

Cable model	Cable length							IP rating	Bending life	Application
	2 m	5 m	10 m	20 m	30 m	40 m	50 m			
MR-ESCBL_M-L	2	5	10	20	(Note) 30			IP20	Standard	HC-SFS, HC-RFS, HC-LFS, HA-LFS series, and HC-UFS 2000 r/min servo motors
MR-ESCBL_M-H	2	5	10	20	(Note) 30	(Note) 40	(Note) 50	IP20	Long bending life	

Note. Four-wire type cable



# 5. OPTIONS AND PERIPHERAL EQUIPMENT

(a) Connection of servo amplifier and servo motor

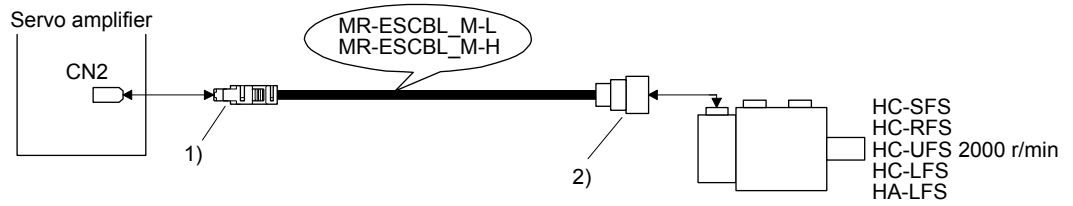

Cable model	1) CN2-side connector	2) Encoder-side connector																																								
MR-ESCBL_M-L	<p>Receptacle: 36210-0100PL Shell kit: 36310-3200-008 (3M)</p> <p>Connector set: 54599-1019 (Molex)</p> <p>View seen from the wiring side. (Note)      View seen from the wiring side. (Note)</p> <p>Note. Do not connect anything to the pins shown as . Especially, pin 10 is provided for manufacturer adjustment. If it is connected with any other pin, the servo amplifier cannot operate normally. Referring POINT of this section, securely connect the shielded cable external conductor of the shielded cable to the ground plate and fix it to the connector shell.</p>	<p>Plug: D/MS3106B20-29S Cable clamp: D/MS3057-12A (DDK)</p> <p>View seen from the wiring side. (Note)</p> <table border="1"> <thead> <tr> <th>Pin</th> <th>Signal</th> <th>Pin</th> <th>Signal</th> </tr> </thead> <tbody> <tr> <td>A</td> <td>MD</td> <td>K</td> <td></td> </tr> <tr> <td>B</td> <td>MDR</td> <td>L</td> <td></td> </tr> <tr> <td>C</td> <td>MR</td> <td>M</td> <td>CONT</td> </tr> <tr> <td>D</td> <td>MRR</td> <td>N</td> <td>SHD</td> </tr> <tr> <td>E</td> <td></td> <td>P</td> <td></td> </tr> <tr> <td>F</td> <td>BAT</td> <td>R</td> <td>LG</td> </tr> <tr> <td>G</td> <td></td> <td>S</td> <td>P5</td> </tr> <tr> <td>H</td> <td></td> <td>T</td> <td></td> </tr> <tr> <td>J</td> <td></td> <td></td> <td></td> </tr> </tbody> </table> <p>Note. Do not connect anything to the pins shown as </p>	Pin	Signal	Pin	Signal	A	MD	K		B	MDR	L		C	MR	M	CONT	D	MRR	N	SHD	E		P		F	BAT	R	LG	G		S	P5	H		T		J			
Pin	Signal	Pin	Signal																																							
A	MD	K																																								
B	MDR	L																																								
C	MR	M	CONT																																							
D	MRR	N	SHD																																							
E		P																																								
F	BAT	R	LG																																							
G		S	P5																																							
H		T																																								
J																																										
MR-ESCBL_M-H																																										

# 5. OPTIONS AND PERIPHERAL EQUIPMENT

(b) Cable internal wiring diagram

MR-ESCBL2M-L  
 MR-ESCBL5M-L  
 MR-ESCBL10M-L

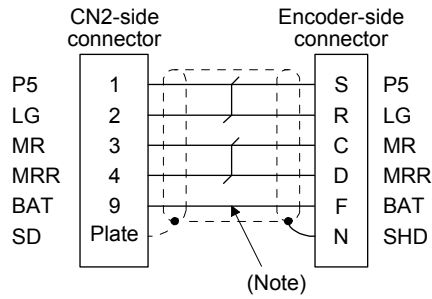

MR-ESCBL20M-L

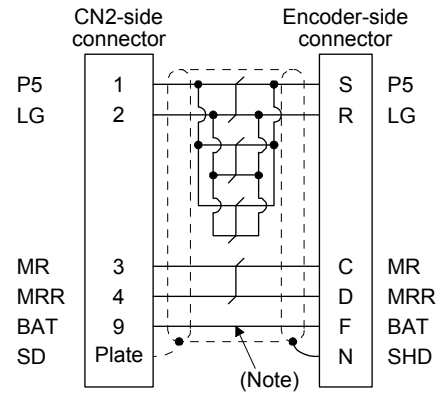

MR-ESCBL2M-H  
 MR-ESCBL5M-H  
 MR-ESCBL10M-H

MR-ESCBL30M-L

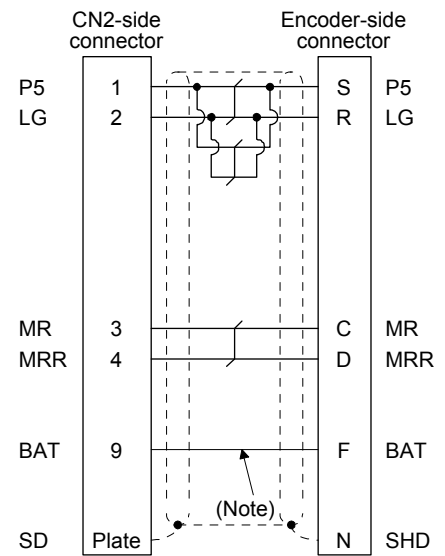
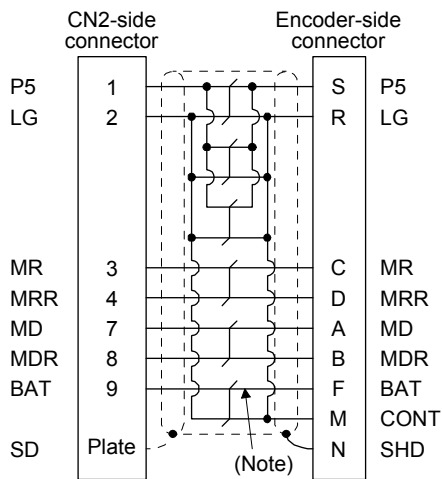

# 5. OPTIONS AND PERIPHERAL EQUIPMENT

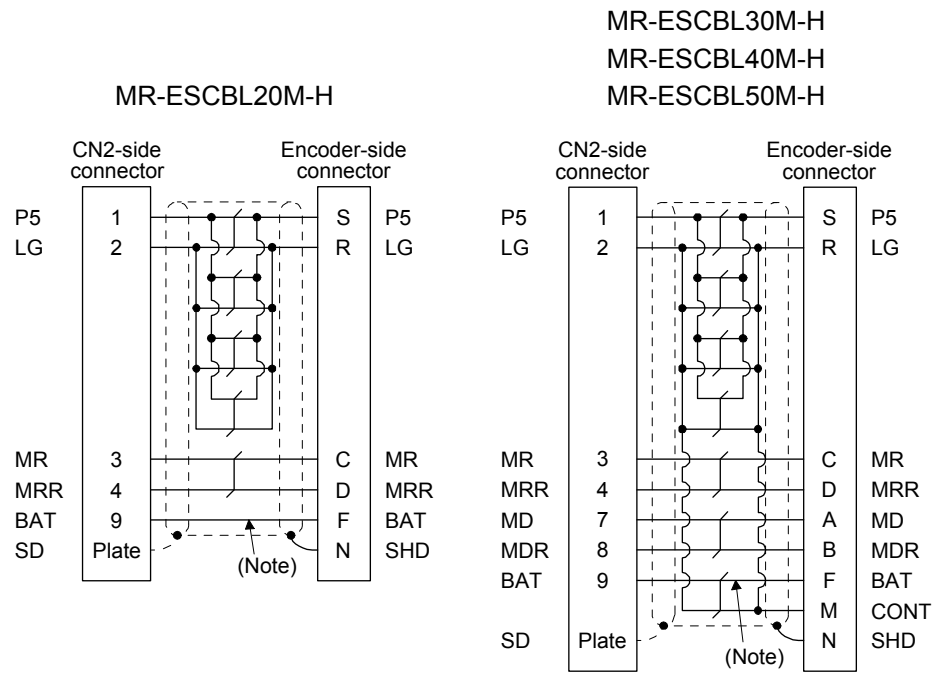

Note. Always make connection for use in an absolute position detection system. Wiring is not necessary for use in an incremental system.

## 5. OPTIONS AND PERIPHERAL EQUIPMENT

### 5.4 Regenerative option



**CAUTION**

● Do not use servo amplifiers with regenerative options other than the combinations specified below.  
Otherwise, it may cause a fire.

#### 5.4.1 Regenerative option of servo amplifier

##### (1) Combination and regenerative power

The power values in the table are resistor-generated powers and not rated powers.

Servo amplifier	Regenerative power [W]							
	Built-in regenerative resistor	MR-RB032 [40 Ω]	MR-RB12 [40 Ω]	MR-RB32 [40 Ω]	MR-RB30 [13 Ω]	(Note 1) MR-RB50 [13 Ω]	MR-RB31 [6.7 Ω]	(Note 1) MR-RB51 [6.7 Ω]
MR-J4-10B-RJ020		30						
MR-J4-20B-RJ020	10	30	100					
MR-J4-40B-RJ020	10	30	100					
MR-J4-60B-RJ020	10	30	100					
MR-J4-70B-RJ020	20	30	100	300				
MR-J4-100B-RJ020	20	30	100	300				
MR-J4-200B-RJ020	100				300	500		
MR-J4-350B-RJ020	100				300	500		
MR-J4-500B-RJ020	130				300	500		
MR-J4-700B-RJ020	170						300	500

Servo amplifier	(Note 2) Regenerative power [W]					
	External regenerative resistor (accessory)	MR-RB5E [6 Ω]	MR-RB5R [3.2 Ω]	MR-RB9P [4.5 Ω]	MR-RB9F [3 Ω]	MR-RB9T [2.5 Ω]
MR-J4-11KB-RJ020	500 (800)	500 (800)	500 (800)			
MR-J4-15KB-RJ020	850 (1300)			850 (1300)	850 (1300)	
MR-J4-22KB-RJ020	850 (1300)				850 (1300)	850 (1300)

Note 1. Always install a cooling fan.

2. Values in parentheses assume the installation of a cooling fan.

## 5. OPTIONS AND PERIPHERAL EQUIPMENT

### (b) 400 V class

Servo amplifier	Regenerative power [W]								
	Built-in regenerative resistor	MR-RB1L-4 [270 Ω]	(Note 1) MR-RB3M-4 [120 Ω]	(Note 1) MR-RB3H-4 [80 Ω]	(Note 1) MR-RB5H-4 [80 Ω]	(Note 1) MR-RB3G-4 [47 Ω]	(Note 1) MR-RB5G-4 [47 Ω]	(Note 1) MR-RB34-4 [26 Ω]	(Note 1) MR-RB54-4 [26 Ω]
MR-J4-60B4-RJ020	15	100							
MR-J4-100B4-RJ020	15		300						
MR-J4-200B4-RJ020	100			300	500				
MR-J4-350B4-RJ020	100					300	500		
MR-J4-500B4-RJ020	130					300	500		
MR-J4-700B4-RJ020	170							300	500

Servo amplifier	(Note 2) Regenerative power [W]				
	External regenerative resistor (accessory)	MR-RB5K-4 [10 Ω]	MR-RB6B-4 [20 Ω]	MR-RB60-4 [12.5 Ω]	MR-RB6K-4 [10 Ω]
MR-J4-11KB4-RJ020	500 (800)	500 (800)	500 (800)		
MR-J4-15KB4-RJ020	850 (1300)			850 (1300)	850 (1300)
MR-J4-22KB4-RJ020	850 (1300)				850 (1300)

- Note 1. Always install a cooling fan.  
 2. Values in parentheses assume the installation of a cooling fan.

### (c) 100 V class

Servo amplifier	Regenerative power [W]		
	Built-in regenerative resistor	MR-RB032 [40 Ω]	MR-RB12 [40 Ω]
MR-J4-10B1-RJ020		30	
MR-J4-20B1-RJ020	10	30	100
MR-J4-40B1-RJ020	10	30	100

#### 5.4.2 Regenerative option of converter unit

##### (1) Combination and regenerative power

The regenerative power values in the table are resistor-regenerated powers and not rated powers.

Converter unit	Drive unit	Regenerative power [W]			
		MR-RB139 (1.3 Ω)	(Note 1) Three MR-RB137 (1.3 Ω) in parallel	MR-RB137-4 (4 Ω) MR-RB136-4 (5 Ω)	(Note 2) Three MR-RB13V-4 (4 Ω) in parallel Three MR-RB138-4 (5 Ω) in parallel
MR-CR55K	MR-J4-DU30KB-RJ020	1300	3900		
	MR-J4-DU37KB-RJ020				
MR-CR55K4	MR-J4-DU30KB4-RJ020			1300	3900
	MR-J4-DU37KB4-RJ020				
	MR-J4-DU45KB4-RJ020				
	MR-J4-DU55KB4-RJ020				

- Note 1. The resultant resistance of three units is 1.3 Ω.  
 2. The resultant resistance of three units is 4 Ω.

## 5. OPTIONS AND PERIPHERAL EQUIPMENT

### (2) Selection of the regenerative option

Use the following method when regeneration occurs continuously in vertical motion applications or when it is desired to make an in-depth selection of the regenerative option.

#### (a) Regenerative energy calculation

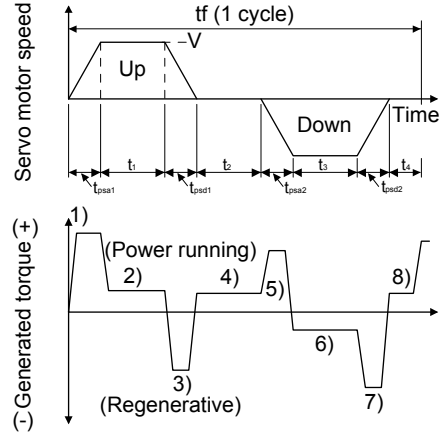
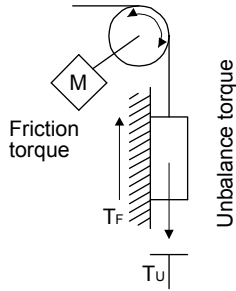

Formulas for calculating torque and energy in operation

Regenerative power	Torque applied to servo motor [N•m]	Energy E [J]
1)	$T_1 = \frac{(J_L/\eta + J_M) \cdot V}{9.55 \cdot 10^4} \cdot \frac{1}{t_{psa1}} + T_U + T_F$	$E_1 = \frac{0.1047}{2} \cdot V \cdot T_1 \cdot t_{psa1}$
2)	$T_2 = T_U + T_F$	$E_2 = 0.1047 \cdot V \cdot T_2 \cdot t_1$
3)	$T_3 = \frac{-(J_L \cdot \eta + J_M) \cdot V}{9.55 \cdot 10^4} \cdot \frac{1}{t_{psa2}} + T_U + T_F$	$E_3 = \frac{0.1047}{2} \cdot V \cdot T_3 \cdot t_{psa2}$
4), 8)	$T_4, T_8 = T_U$	$E_4, E_8 \geq 0$ (No regeneration)
5)	$T_5 = \frac{(J_L/\eta + J_M) \cdot V}{9.55 \cdot 10^4} \cdot \frac{1}{t_{psd2}} - T_U + T_F$	$E_5 = \frac{0.1047}{2} \cdot V \cdot T_5 \cdot t_{psd2}$
6)	$T_6 = -T_U + T_F$	$E_6 = 0.1047 \cdot V \cdot T_6 \cdot t_3$
7)	$T_7 = \frac{-(J_L \cdot \eta + J_M) \cdot V}{9.55 \cdot 10^4} \cdot \frac{1}{t_{psd2}} - T_U + T_F$	$E_7 = \frac{0.1047}{2} \cdot V \cdot T_7 \cdot t_{psd2}$

From the calculation results in 1) to 8), find the absolute value ( $E_s$ ) of the sum total of negative energies.

## 5. OPTIONS AND PERIPHERAL EQUIPMENT

### (b) Losses of servo motor and servo amplifier in regenerative mode

The following table lists the efficiencies and other data of the servo motor and servo amplifier in the regenerative mode.

Servo amplifier	Inverse efficiency [%]	Capacitor charging [J]
MR-J4-10B-RJ020	55	9
MR-J4-20B-RJ020	70	9
MR-J4-40B-RJ020	85	11
MR-J4-60B-RJ020	85	11
MR-J4-70B-RJ020	80	18
MR-J4-100B-RJ020	80	18
MR-J4-200B-RJ020	85	36
MR-J4-350B-RJ020	85	40
MR-J4-500B-RJ020	90	45
MR-J4-700B-RJ020	90	70
MR-J4-11KB-RJ020	90	120
MR-J4-15KB-RJ020	90	170
MR-J4-22KB-RJ020	90	250

Servo amplifier	Inverse efficiency [%]	Capacitor charging [J]
MR-J4-60B4-RJ020	85	12
MR-J4-100B4-RJ020	80	12
MR-J4-200B4-RJ020	85	25
MR-J4-350B4-RJ020	85	43
MR-J4-500B4-RJ020	90	45
MR-J4-700B4-RJ020	90	70
MR-J4-11KB4-RJ020	90	120
MR-J4-15KB4-RJ020	90	170
MR-J4-22KB4-RJ020	90	250
MR-J4-10B1-RJ020	55	4
MR-J4-20B1-RJ020	75	4
MR-J4-40B1-RJ020	85	10

### (c) Regenerative loss of servo motor and drive unit

The following table lists the efficiencies and other data of the servo motor and drive unit in the regenerative mode.

Converter unit	Drive unit	Inverse efficiency [%]	Capacitor charging [J]
MR-CR55K	MR-J4-DU30KB-RJ020	90	450
	MR-J4-DU37KB-RJ020		
MR-CR55K4	MR-J4-DU30KB4-RJ020		
	MR-J4-DU37KB4-RJ020		
	MR-J4-DU45KB4-RJ020		
	MR-J4-DU55KB4-RJ020		

Inverse efficiency ( $\eta$ ): Efficiency including some efficiencies of the servo motor and servo amplifier when rated (regenerative) torque is generated at rated speed. Since the efficiency varies with the speed and generated torque, allow for about 10%.

Capacitor charging ( $E_c$ ): Energy charged into the electrolytic capacitor in the servo amplifier

Subtract the capacitor charging from the result of multiplying the sum total of regenerative energies by the inverse efficiency to calculate the energy consumed by the regenerative option.

$$ER [J] = \eta \cdot E_s - E_c$$

Calculate the power consumption of the regenerative option on the basis of one-cycle operation period  $t_f$  [s] to select the necessary regenerative option.

$$PR [W] = ER/t_f$$

## 5. OPTIONS AND PERIPHERAL EQUIPMENT

---

### (3) Parameter setting

#### (a) Servo amplifier

Set [Pr.2] according to the option to be used.

[Pr. 2]

0	0		
---	---	--	--

- 00: Regenerative option is not used.
  - For servo amplifier of 100 W, regenerative option is not used.
  - For servo amplifier of 0.2 kW to 7 kW, built-in regenerative resistor is used.
  - Supplied regenerative resistors or regenerative option is used with the servo amplifier of 11 kW to 22 kW.
- 01: FR-RC/FR-RC-H/FR-CV/FR-CV-H/FR-BU2/FR-BU2-H
- 05: MR-RB32
- 08: MR-RB30
- 09: MR-RB50 (Cooling fan is required.)
- 0B: MR-RB31
- 0C: MR-RB51 (Cooling fan is required.)
- 0E: When the supplied regenerative resistors are cooled by the cooling fan to increase the ability with the servo amplifier of 11 kW to 22 kW.
- 10: MR-RB032
- 11: MR-RB12
- 13: MR-RB5E
- 14: MR-RB5E (Cooling fan is required.)
- 17: MR-RB9F
- 18: MR-RB9F (Cooling fan is required.)
- 20: MR-RB3N
- 21: MR-RB5N (Cooling fan is required.)
- 23: MR-RB5R
- 24: MR-RB5R (Cooling fan is required.)
- 25: MR-RB9P
- 26: MR-RB9P (Cooling fan is required.)
- 27: MR-RB9T
- 28: MR-RB9T (Cooling fan is required.)
- 80: MR-RB3H-4 (Cooling fan is required.)
- 81: MR-RB5H-4 (Cooling fan is required.)
- 82: MR-RB3G-4 (Cooling fan is required.)
- 83: MR-RB5G-4 (Cooling fan is required.)
- 84: MR-RB34-4 (Cooling fan is required.)
- 85: MR-RB54-4 (Cooling fan is required.)
- 86: MR-RB1L-4
- 87: MR-RB3M-4 (Cooling fan is required.)
- 90: MR-RB1H-4
- 94: MR-RB5K-4
- 95: MR-RB5K-4 (Cooling fan is required.)
- 96: MR-RB6B-4
- 97: MR-RB6B-4 (Cooling fan is required.)
- 98: MR-RB6K-4
- 99: MR-RB6K-4 (Cooling fan is required.)
- 9A: MR-RB60-4
- 9B: MR-RB60-4 (Cooling fan is required.)
- 9C: MR-RB3U-4 (Cooling fan is required.)
- 9D: MR-RB5U-4 (Cooling fan is required.)



## 5. OPTIONS AND PERIPHERAL EQUIPMENT

### (b) Converter unit

POINT
<ul style="list-style-type: none"><li>● The regenerative option cannot be connected to the drive unit. Always set [Pr. PA02] of the drive unit to " __ 0 0" (regenerative option is not used).</li><li>● When using the regenerative option for MR-J2S-_B4, set 11 or 12.</li></ul>

Set [Pr. PA01] of the converter unit according to the option to be used.

[Pr. PA01]

0	0		
---	---	--	--

Selection of regenerative option  
00: Not used  
01: MR-RB139  
02: MR-RB137 (three units)  
11: MR-RB136-4  
12: MR-RB138-4 (three units)  
13: MR-RB137-4  
14: MR-RB13V-4 (three units)

### (4) Connection of regenerative option

POINT
<ul style="list-style-type: none"><li>● When MR-RB50, MR-RB51, MR-RB3M-4, MR-RB3G-4, MR-RB5G-4, MR-RB34-4, MR-RB54-4, MR-RB3H-4, or MR-RB5H-4 is used, a cooling fan is required to cool it. The cooling fan should be prepared by the customer.</li><li>● For the wire sizes used for wiring, refer to chapter 6.</li></ul>

### (a) Servo amplifier

The regenerative option generates heat of 100 °C higher than the ambient temperature. Fully consider heat dissipation, installation position, wires used, etc. before installing the option. For wiring, use flame-resistant wires or make the wires flame-resistant and keep them away from the regenerative option. Use twisted wires of up to 5 m for connecting with the servo amplifier.

## 5. OPTIONS AND PERIPHERAL EQUIPMENT

### 1) MR-J4-500B-RJ020 or less/MR-J4-350B4-RJ020 or less

Always remove the wiring from across P+ to D and fit the regenerative option across P+ to C. G3 and G4 are terminals for thermal sensor. Between G3 and G4 is opened when the regenerative option overheats abnormally.

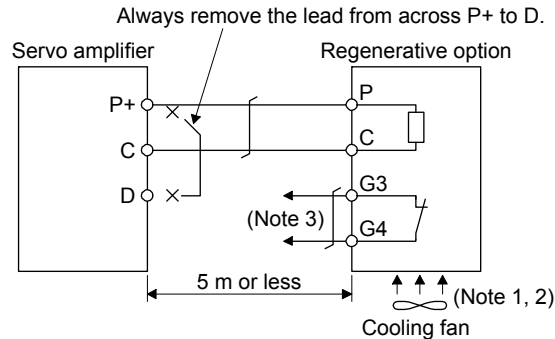

- Note 1. When using the MR-RB50, MR-RB3M-4, MR-RB3G-4, MRRB5G-4, MR-RB3H-4, or MR-RB5H-4, forcibly cool it with a cooling fan (1.0 m<sup>3</sup>/min or more, 92 mm × 92 mm).
2. When the ambient temperature is more than 55 °C and the regenerative load ratio is more than 60% in MR-RB30, MR-RB31 and MR-RB32, forcibly cool the air with a cooling fan (1.0 m<sup>3</sup>/min or more, 92 mm × 92 mm). A cooling fan is not required if the ambient temperature is 35 °C or less. (A cooling fan is required for the shaded area in the following graph.)

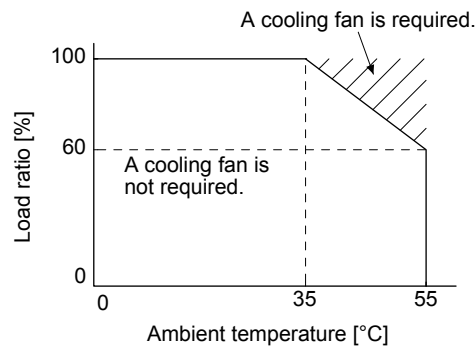

3. Make up a sequence which will switch off the magnetic contactor when abnormal heating occurs.

G3-G4 contact specifications

- Maximum voltage: 120 V AC/DC
- Maximum current: 0.5 A/4.8 V DC
- Maximum capacity: 2.4 VA

## 5. OPTIONS AND PERIPHERAL EQUIPMENT

### 2) MR-J4-700B-RJ020/MR-J4-500B4-RJ020/MR-J4-700B4-RJ020

Always remove the wiring (across P+ to C) of the servo amplifier built-in regenerative resistor and fit the regenerative option across P+ to C. G3 and G4 are terminals for thermal sensor. Between G3 and G4 is opened when the regenerative option overheats abnormally.

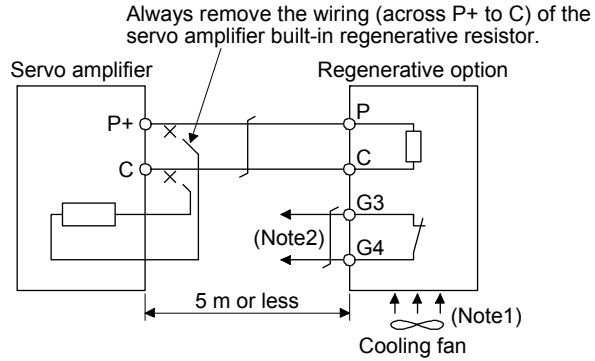

- Note 1. When using the MR-RB51, MR-RB34-4, MR-RB54-4, MR-RB3G-4, or MR-RB5G-4, forcibly cool it with a cooling fan (1.0 m<sup>3</sup>/min or more, 92 mm × 92 mm).
- Note 2. Make up a sequence which will switch off the magnetic contactor when abnormal heating occurs.

G3-G4 contact specifications

Maximum voltage: 120 V AC/DC

Maximum current: 0.5 A/4.8 V DC

Maximum capacity: 2.4 VA

When using the regenerative option, remove the servo amplifier's built-in regenerative resistor wires (across P+ to C), fit them back to back, and secure them to the frame with the accessory screw as shown below.

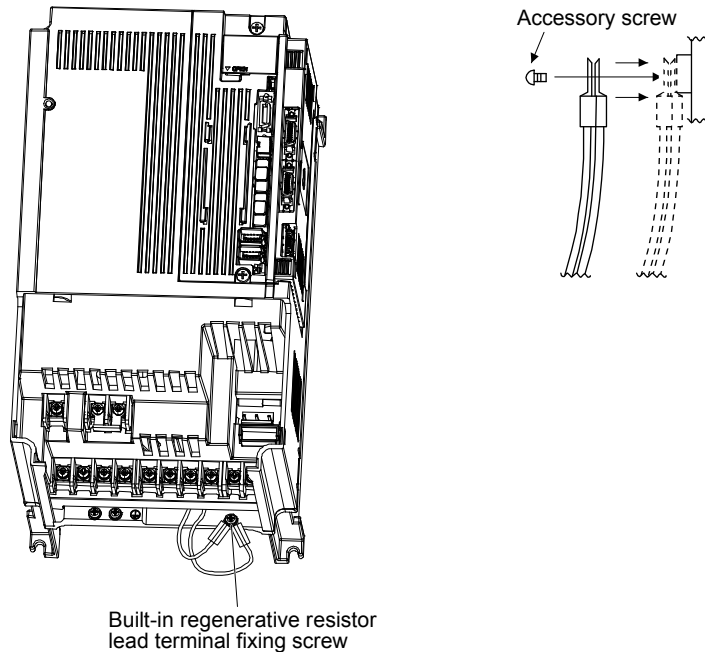

## 5. OPTIONS AND PERIPHERAL EQUIPMENT

### (b) Converter unit

Always supply the following power to a cooling fan.

Table 5.1 Cooling fan

Item	200 V class	400 V class
Model	MR-RB137/MR-RB139	MR-RB137-4/MR-RB13V-4/ MR-RB136-4/MR-RB138-4
Voltage/frequency	1-phase 198 V AC to 242 V AC, 50 Hz/60 Hz	1-phase 380 V AC to 480 V AC, 50 Hz/60 Hz
Power consumption [W]	20 (50 Hz)/18 (60 Hz)	20 (50 Hz)/18 (60 Hz)

The regenerative option generates heat of 100 °C higher than the ambient temperature. Fully consider heat dissipation, installation position, wires used, etc. before installing the option. For wiring, use flame-resistant wires or make the wires flame-resistant and keep them away from the regenerative option. The G3 and G4 terminals act as a thermal protector. Between G3 and G4 is opened when the regenerative option overheats abnormally.

Use twisted wires of up to 5 m for connecting with the converter unit.

#### 1) MR-RB139/MR-RB137-4/MR-RB136-4

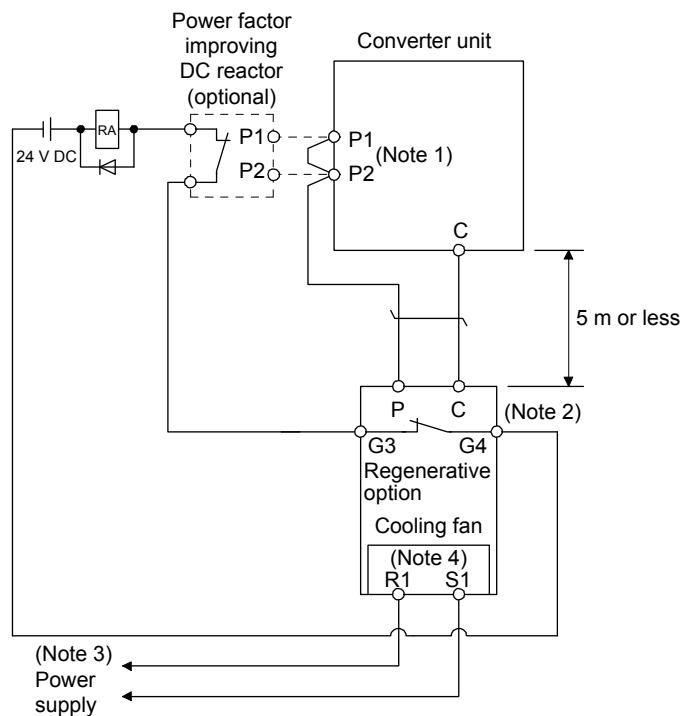

Note 1. When using the power factor improving DC reactor, remove the short bar across P1 and P2.

Note 2. G3-G4 contact specifications

Maximum voltage: 120 V AC/DC

Maximum current: 0.5 A/4.8 V DC

Maximum capacity: 2.4 VA

Note 3. For specifications of the cooling fan power supply, refer to table 5.1.

Note 4. For MR-RB137-4 and MR-RB136-4, "R1" is "R400" and "S1" is "S400".

## 5. OPTIONS AND PERIPHERAL EQUIPMENT

### 2) MR-RB137/MR-RB13V-4/MR-RB138-4

POINT
<p>● Three of MR-RB137, MR-RB13V-4, or MR-RB138-4 are required per converter unit. Please purchase three of MR-RB137, MR-RB13V-4, or MR-RB138-4.</p>

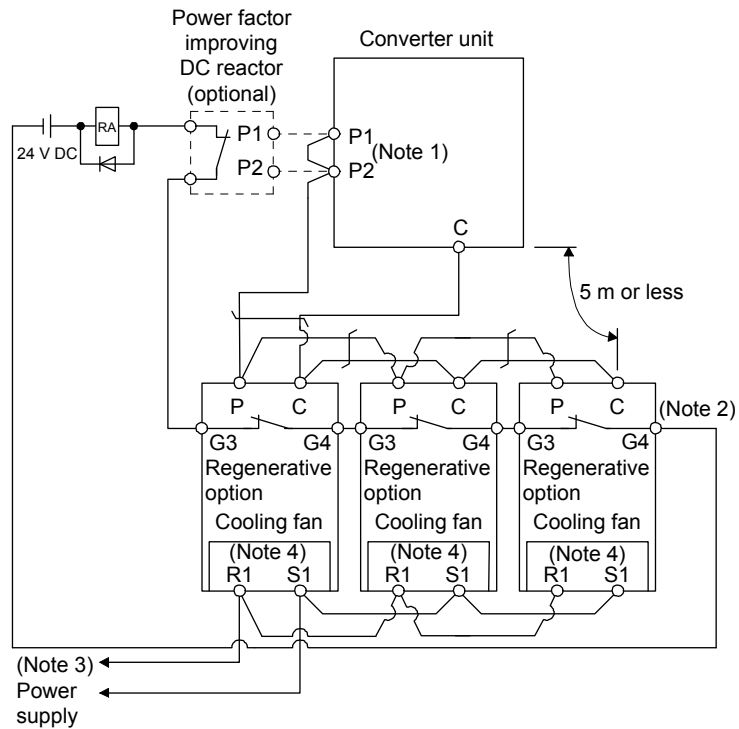

- Note 1. When using the power factor improving DC reactor, remove the short bar across P1 and P2.
- Note 2. G3-G4 contact specifications  
 Maximum voltage: 120 V AC/DC  
 Maximum current: 0.5 A/4.8 V DC  
 Maximum capacity: 2.4 VA
- Note 3. For specifications of the cooling fan power supply, refer to table 5.1.
- Note 4. For MR-RB13V-4 and MR-RB138-4, "R1" is "R400" and "S1" is "S400".

## 5. OPTIONS AND PERIPHERAL EQUIPMENT

- (5) MR-J4-11KB-RJ020 to MR-J4-22KB-RJ020/MR-J4-11KB-RJ020 to MR-J4-22KB-RJ020 (when using the supplied regenerative resistor)

### CAUTION

- Note the followings for supplied regenerative resistors of 11 kW to 22 kW servo amplifiers because they do not have protective covers.
  - Touching the resistor will cause a burn because the surface of the parts is a resistive element and very high temperature.
  - Even if the power turned off, touching the resistor will cause an electric shock because the capacitor of the servo amplifier is charged for a while.

When using the regenerative resistors supplied to the servo amplifier, the specified number of resistors (4 or 5 resistors) must be connected in series. If they are connected in parallel or in less than the specified number, the servo amplifier may become faulty and/or the regenerative resistors burn. Install the resistors at intervals of about 70 mm. Cooling the resistors with two cooling fans (92 × 92, minimum air flow: 1.0 m<sup>3</sup>) improves the regeneration capability. In this case, set "\_ \_ 0 E" in [Pr. 2].

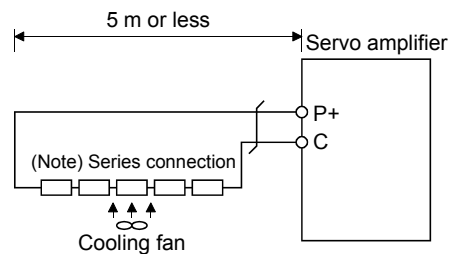

Note. The number of resistors connected in series depends on the resistor type. The thermal sensor is not mounted on the attached regenerative resistor. An abnormal heating of resistor may be generated at a regenerative circuit failure. Install a thermal sensor near the resistor and establish a protective circuit to shut off the main circuit power supply when abnormal heating occurs. The detection level of the thermal sensor varies according to the settings of the resistor. Set the thermal sensor in the most appropriate position on your design basis, or use the thermal sensor built-in regenerative option. (MR-RB5E, MR-RB5R, MR-RB9P, MR-RB9F, MR-RB9T, MR-RB5K-4, MR-RB6B-4, MR-RB60-4, or MR-RB6K-4)

Servo amplifier	Regenerative resistor	Regenerative power [W]		Resultant resistance [Ω]	Number of resistors
		Normal	Cooling		
MR-J4-11KB-RJ020	GRZG400-0.8Ω	500	800	3.2	4
MR-J4-15KB-RJ020	GRZG400-0.6Ω	850	1300	3	5
MR-J4-22KB-RJ020	GRZG400-0.5Ω			2.5	
MR-J4-11KB4-RJ020	GRZG400-2.5Ω	500	800	10	4
MR-J4-15KB4-RJ020	GRZG400-2Ω	850	1300	10	5
MR-J4-22KB4-RJ020					

## 5. OPTIONS AND PERIPHERAL EQUIPMENT

- (6) MR-J4-11KB-RZ020 to MR-J4-22KB-RZ020/MR-J4-11KB4-RZ020 to MR-J4-22KB4-RZ020 (when using the regenerative option)

MR-J4-11KB-RZ020 to MR-J4-22KB-RZ020/MR-J4-11KB4-RZ020 to MR-J4-22KB4-RZ020 servo amplifiers are not supplied with regenerative resistors. When using any of these servo amplifiers, always use the MR-RB5E, MR-RB5R, MR-RB9P, MR-RB9F, MR-RB9T, MR-RB5K-4, MR-RB6B-4, MR-RB60-4, or MR-RB6K-4.

Cooling the regenerative option with cooling fans improves regenerative capability. G3 and G4 are terminals for thermal sensor. Between G3 and G4 is opened when the regenerative option overheats abnormally.

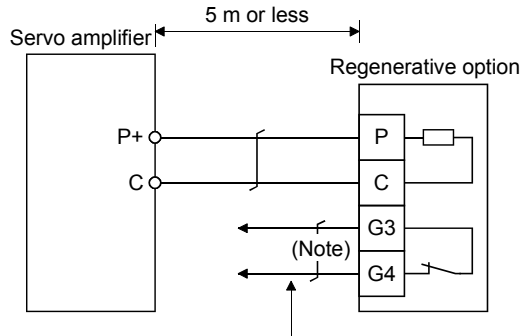

Configure up a circuit which shuts off main circuit power when thermal protector operates.

Note. G3-G4 contact specifications  
 Maximum voltage: 120 V AC/DC  
 Maximum current: 0.5 A/4.8 V DC  
 Maximum capacity: 2.4 VA

Servo amplifier	Regenerative option	Resistance [Ω]	Regenerative power [W]	
			Without cooling fans	With cooling fans
MR-J4-11KB-RZ020	MR-RB5E	6	500	800
	MR-RB5R	3.2		
MR-J4-15KB-RZ020	MR-RB9P	4.5	850	1300
	MR-RB9F	3		
MR-J4-22KB-RZ020	MR-RB9T	2.5	850	1300
MR-J4-11KB4-RZ020	MR-RB5K-4	10	500	800
	MR-RB6B-4	20		
MR-J4-15KB4-RZ020	MR-RB60-4	12.5	850	1300
MR-J4-22KB4-RZ020	MR-RB6K-4	10		

When using cooling fans, install them using the mounting holes provided in the bottom of the regenerative option.

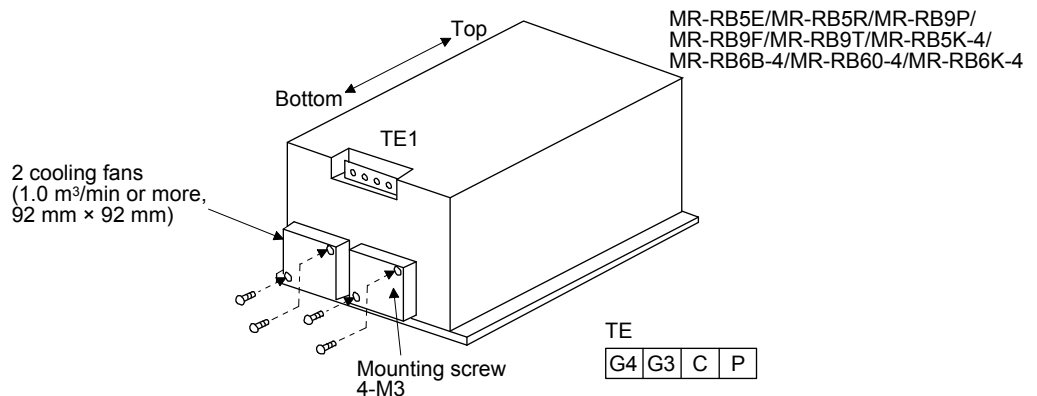

# 5. OPTIONS AND PERIPHERAL EQUIPMENT

## (7) Dimensions (a) MR-RB12

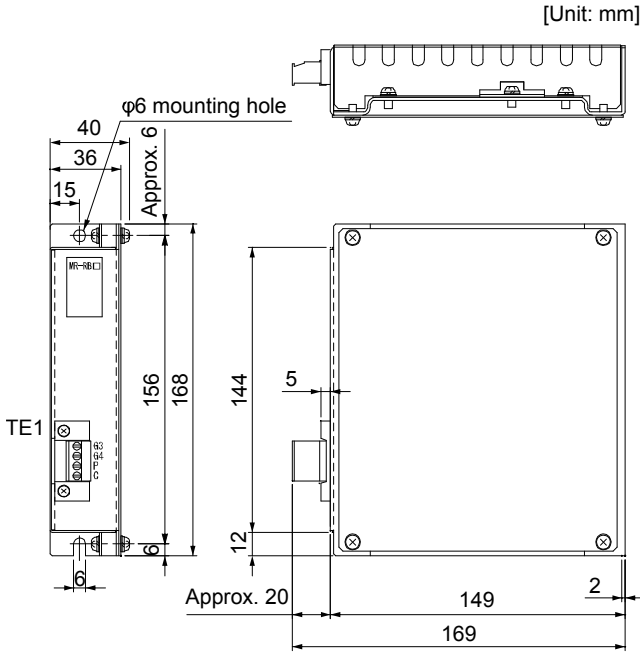

• TE1 terminal block

G3
G4
P
C

Applicable wire size: 0.2 mm<sup>2</sup> to 2.5 mm<sup>2</sup> (AWG 24 to 12)

Tightening torque: 0.5 to 0.6 [N•m]

• Mounting screw

Screw size: M5

Tightening torque: 3.24 [N•m]

Mass: 1.1 [kg]

## (b) MR-RB30/MR-RB31/MR-RB32/MR-RB34-4/MR-RB3M-4/MR-RB3G-4/MR-RB3H-4

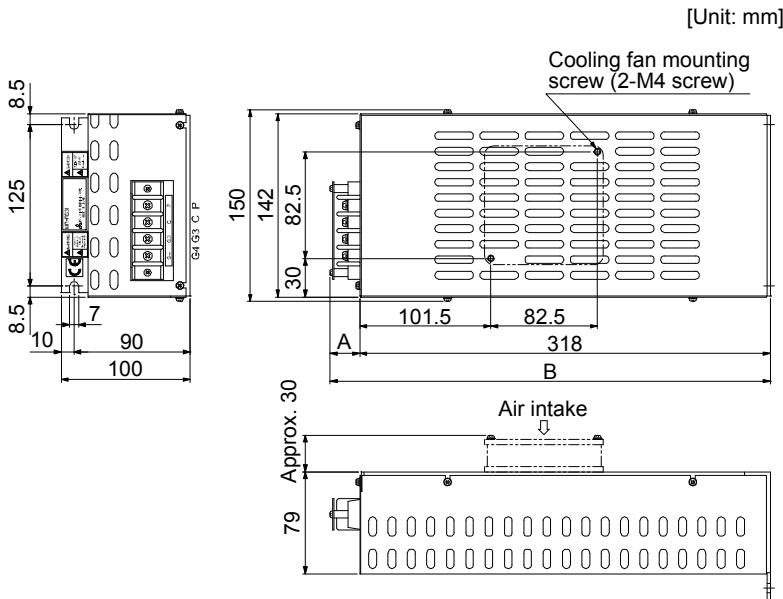

• Terminal block

P
C
G3
G4

Terminal screw size: M4

Tightening torque: 1.2 [N•m]

• Mounting screw

Screw size: M6

Tightening torque: 5.4 [N•m]

Regenerative option	Variable dimensions		Mass [kg]
	A	B	
MR-RB30	17	335	2.9
MR-RB31			
MR-RB32			
MR-RB34-4	23	341	
MR-RB3M-4			
MR-RB3G-4			
MR-RB3H-4			



## 5. OPTIONS AND PERIPHERAL EQUIPMENT

(c) MR-RB50/MR-RB51/MR-RB54-4/MR-RB5G-4/MR-RB5H-4

[Unit: mm]

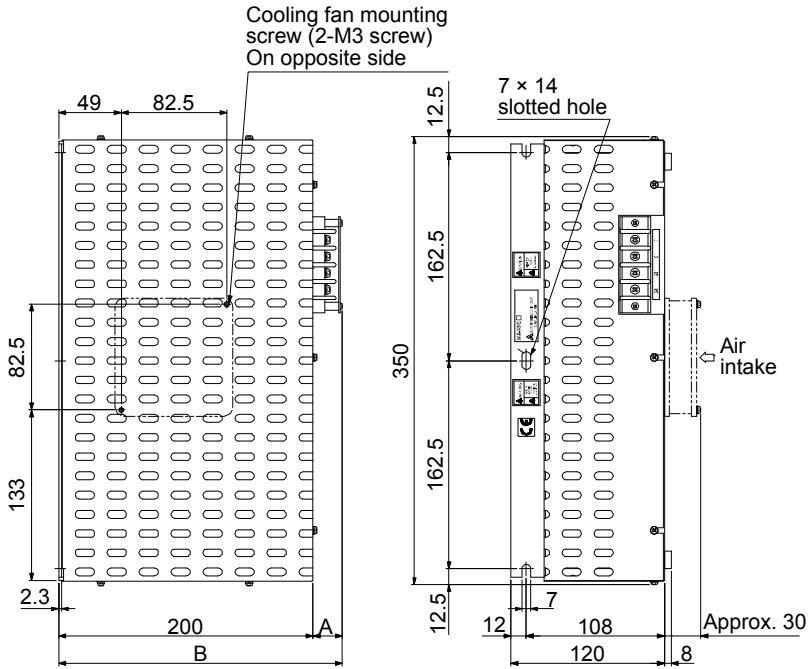

• Terminal block

P
C
G3
G4

Terminal screw size: M4  
Tightening torque: 1.2 [N•m]

• Mounting screw  
Screw size: M6  
Tightening torque: 5.4 [N•m]

Regenerative option	Variable dimensions		Mass [kg]
	A	B	
MR-RB50	17	217	5.6
MR-RB51			
MR-RB54-4	23	223	
MR-RB5G-4			
MR-RB5H-4			

(d) MR-RB032

[Unit: mm]

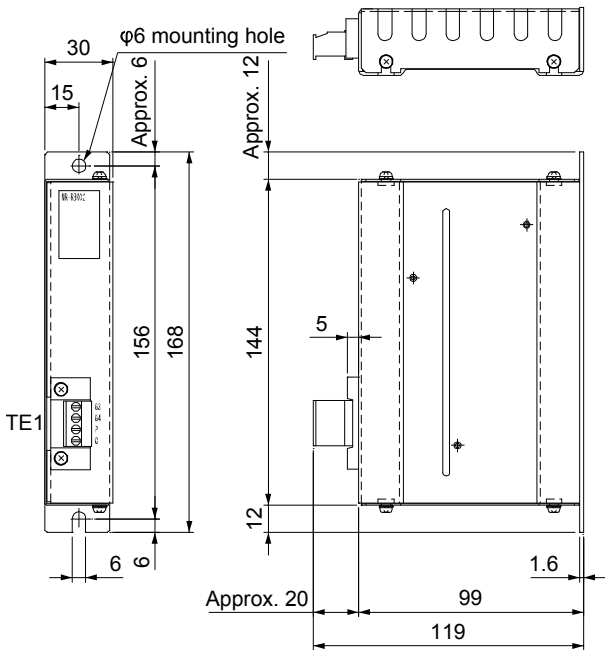

• TE1 terminal block

G3
G4
P
C

Applicable wire size: 0.2 mm<sup>2</sup> to 2.5 mm<sup>2</sup> (AWG 24 to 12)  
Tightening torque: 0.5 to 0.6 [N•m]

• Mounting screw  
Screw size: M5  
Tightening torque: 3.24 [N•m]

Mass: 0.5 [kg]

# 5. OPTIONS AND PERIPHERAL EQUIPMENT

(e) MR-RB1L-4

[Unit: mm]

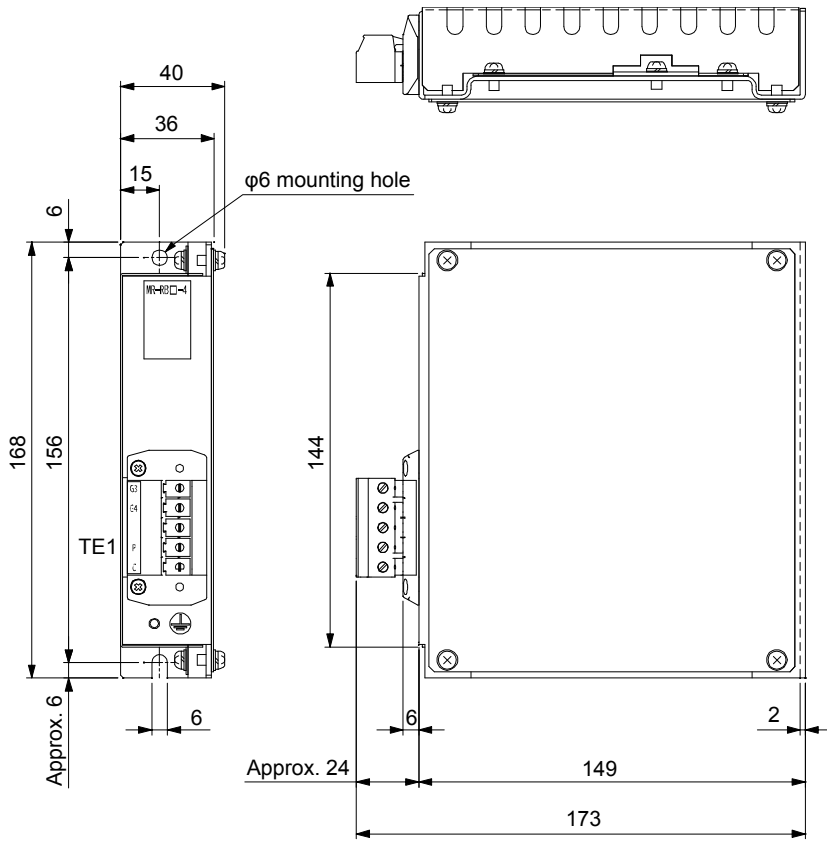

• Terminal

G3
G4
P
C

Applicable wire size: AWG 24 to 10  
Tightening torque: 0.5 to 0.6 [N·m]

• Mounting screw

Screw size: M5  
Tightening torque: 3.24 [N·m]

Mass: 1.1 [kg]

## 5. OPTIONS AND PERIPHERAL EQUIPMENT

### (f) MR-RB5E/MR-RB5R/MR-RB9P/MR-RB9F/MR-RB9T/MR-RB5K-4/MR-RB6B-4/MR-RB60-/MR-RB6K-4

[Unit: mm]

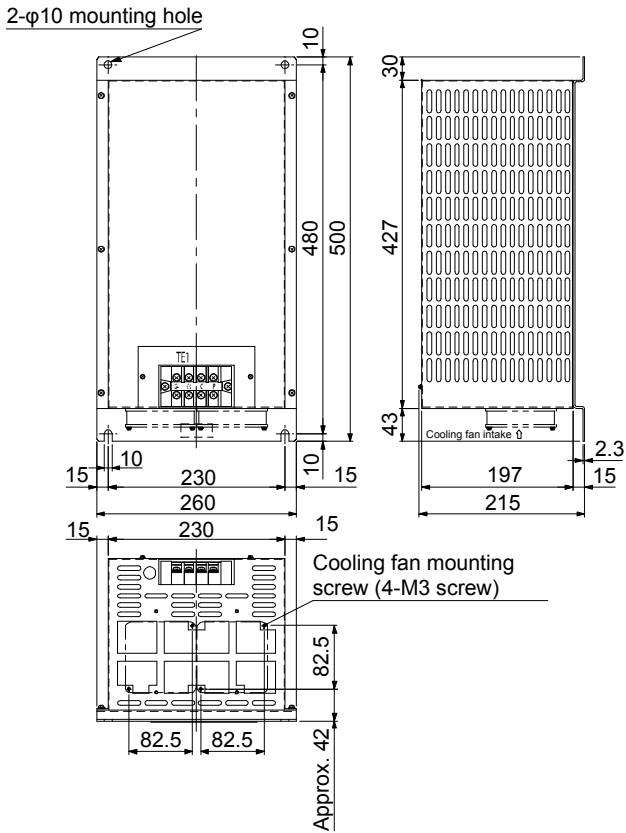

• Terminal block

G4	G3	C	P
----	----	---	---

Terminal screw size: M5  
Tightening torque: 2.0 [N·m]

• Mounting screw

Screw size: M8  
Tightening torque: 13.2 [N·m]

Regenerative option	Mass [kg]
MR-RB5E	10
MR-RB5R	
MR-RB9P	11
MR-RB9F	
MR-RB9T	10
MR-RB5K-4	
MR-RB6B-4	11
MR-RB60-4	
MR-RB6K-4	

### (g) GRZG400-0.8Ω/GRZG400-0.6Ω/GRZG400-0.5Ω/GRZG400-2.5Ω/GRZG400-2.0Ω (standard accessories)

[Unit: mm]

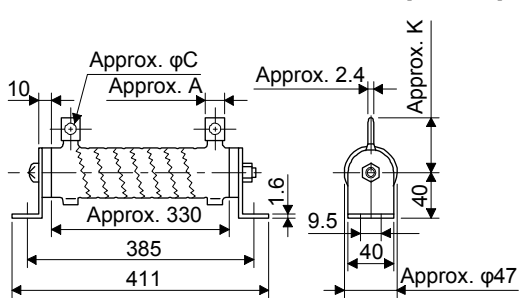

Regenerative resistor	Variable dimensions			Mounting screw size	Tightening torque [N·m]	Mass [kg]
	A	C	K			
GRZG400-0.8Ω	10	5.5	39	M8	13.2	0.8
GRZG400-0.6Ω	16	8.2	46			
GRZG400-0.5Ω						
GRZG400-2.5Ω	10	5.5	39			
GRZG400-2.0Ω						

# 5. OPTIONS AND PERIPHERAL EQUIPMENT

(h) MR-RB139/MR-RB137/MR-RB137-4/MR-RB13V-4/MR-RB136-4/MR-RB138-4

[Unit: mm]

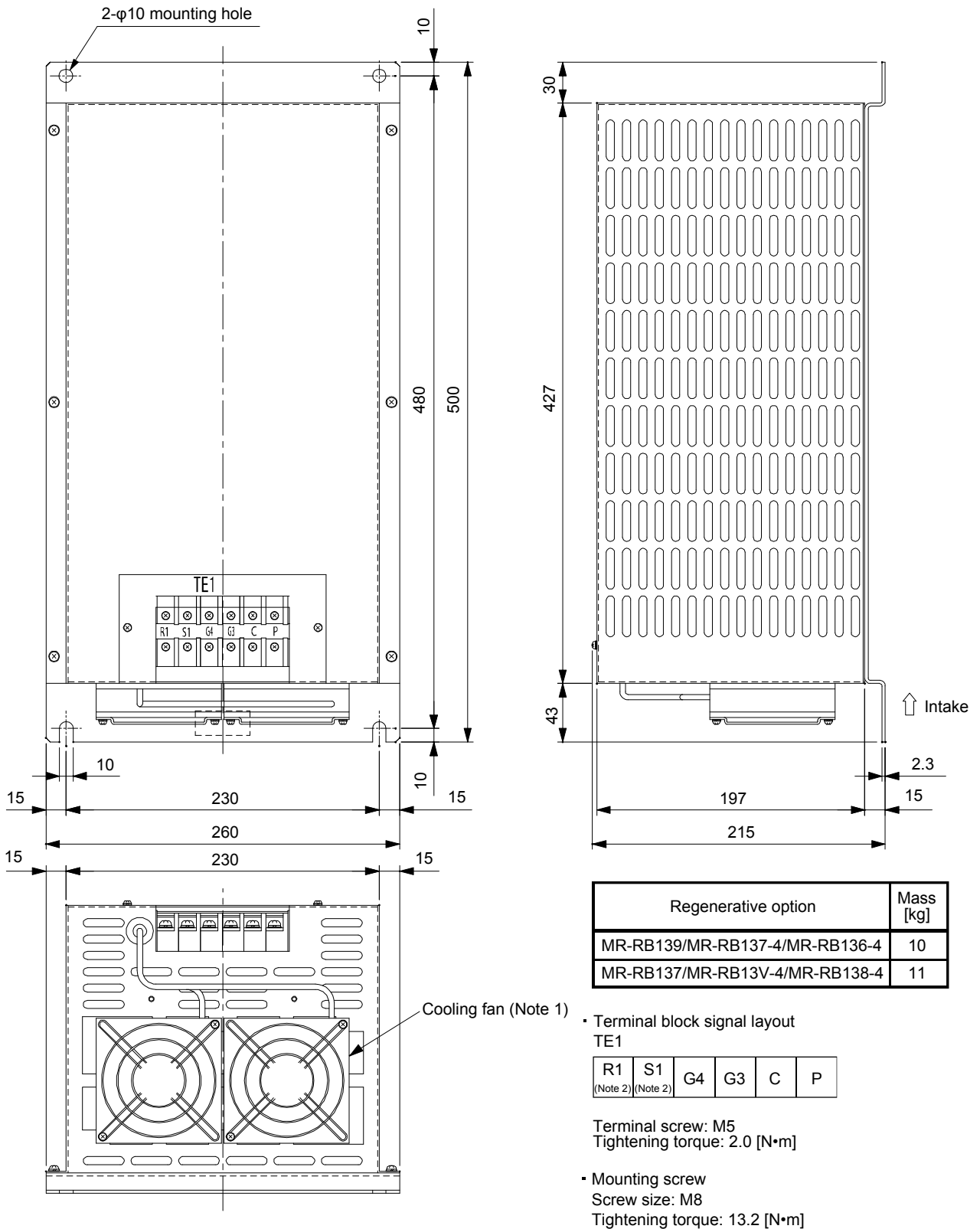

- Note 1. One cooling fan for MR-RB137-4/MR-RB13V-4/MR-RB136-4/MR-RB138-4.  
 Note 2. For MR-RB137-4/MR-RB13V-4/MR-RB136-4/MR-RB138-4, "R1" is "R400" and "S1" is "S400".



## 6. SELECTION EXAMPLE OF WIRES

### 6. SELECTION EXAMPLE OF WIRES

#### 6.1 Servo amplifier

POINT
● We recommend using HIV wires to wire the servo amplifiers, options, and peripheral equipment. Therefore, the recommended wire sizes may differ from those used for the previous servo amplifiers.
● Selection conditions of wire size are as follows. Construction condition: Single wire set in midair Wire length: 30 m or less

The following diagram shows the wires used for wiring. Use the wires given in this section or equivalent.

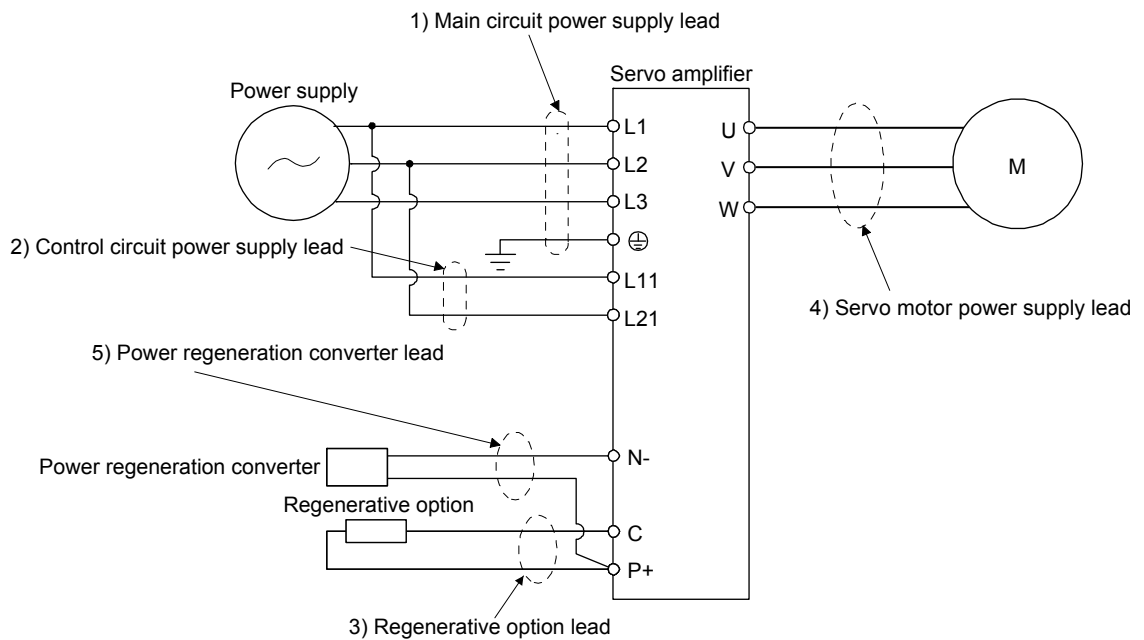

## 6. SELECTION EXAMPLE OF WIRES

### (1) Example of selecting the wire sizes

Use the 600 V Grade heat-resistant polyvinyl chloride insulated wire (HIV wire) for wiring. The following shows the wire size selection example.

#### (a) 200 V class

Servo amplifier	Wire [mm <sup>2</sup> ] (Note 1)			
	1) L1/L2/L3/⊕	2) L11/L21	3) P+/C	4) U/V/W/⊕
MR-J4-10B-RJ020	2 (AWG 14)	1.25 to 2 (AWG 16 to 14)	2 (AWG 14)	AWG 18 to 14
MR-J4-20B-RJ020				
MR-J4-40B-RJ020				
MR-J4-60B-RJ020				
MR-J4-70B-RJ020				
MR-J4-100B-RJ020				
MR-J4-200B-RJ020				AWG 16 to 10
MR-J4-350B-RJ020	3.5 (AWG 12)			
MR-J4-500B-RJ020 (Note 2)	5.5 (AWG 10): a	1.25 (AWG 16): a 2 (AWG 14): d	2 (AWG 14): c	2 (AWG 14): c 3.5 (AWG 12): a 5.5 (AWG 10): a
MR-J4-700B-RJ020 (Note 2)	8 (AWG 8): b			2 (AWG 14): c 3.5 (AWG 12): a 5.5 (AWG 10): a 8 (AWG 8): b
MR-J4-11KB-RJ020 (Note 2)	14 (AWG 6): f	1.25 (AWG 16): c 2 (AWG 14): c	3.5 (AWG 12): g	22 (AWG 4): h
MR-J4-15KB-RJ020 (Note 2)	22 (AWG 4): h		5.5 (AWG 10): g	30 (AWG 2): l
MR-J4-22KB-RJ020 (Note 2)	38 (AWG 2): i		5.5 (AWG 10): j	60 (AWG 2/0): m

Note 1. Alphabets in the table indicate crimping tools. For crimp terminals and applicable tools, refer to (2) in this chapter.

2. To connect these models to a terminal block, be sure to use the screws that come with the terminal block.

Use wires (5) of the following sizes with the power regeneration converter (FR-RC).

Model	Wire [mm <sup>2</sup> ]
FR-RC-15K	14 (AWG 6)
FR-RC-30K	14 (AWG 6)
FR-RC-55K	22 (AWG 4)

## 6. SELECTION EXAMPLE OF WIRES

### (b) 400 V class

Servo amplifier	Wire [mm <sup>2</sup> ] (Note 1)			
	1) L1/L2/L3/⊕	2) L11/L21	3) P+/C	4) U/V/W/⊕
MR-J4-60B4-RJ020/ MR-J4-100B4-RJ020	2 (AWG 14)	1.25 to 2 (AWG 16 to 14)	2 (AWG 14)	AWG 16 to 14
MR-J4-200B4-RJ020				
MR-J4-350B4-RJ020				
MR-J4-500B4-RJ020 (Note 2)	2 (AWG 14): b	1.25 (AWG 16): a 2 (AWG 14): c	2 (AWG 14): b	3.5 (AWG 12): a
MR-J4-700B4-RJ020 (Note 2)	3.5 (AWG 12): a			5.5 (AWG 10): a
MR-J4-11KB4-RJ020 (Note 2)	5.5 (AWG 10): d	1.25 (AWG 16): b 2 (AWG 14): b	2 (AWG 14): f	8 (AWG 8): g
MR-J4-15KB4-RJ020 (Note 2)	8 (AWG 8): g		3.5 (AWG 12): d	22 (AWG 4): j
MR-J4-22KB4-RJ020 (Note 2)	14 (AWG 6): i		3.5 (AWG 12): e	

- Note 1. Alphabets in the table indicate crimping tools. For crimp terminals and applicable tools, refer to (2) in this chapter.
2. To connect these models to a terminal block, be sure to use the screws that come with the terminal block.

Use wires (5)) of the following sizes with the power regeneration converter (FR-RC-H).

Model	Wire [mm <sup>2</sup> ]
FR-RC-H15K	14 (AWG6)
FR-RC-H30K	
FR-RC-H55K	

### (c) 100 V class

Servo amplifier	Wire [mm <sup>2</sup> ]			
	1) L1/L2/⊕	2) L11/L21	3) P+/C	4) U/V/W/⊕
MR-J4-10B1-RJ020	2 (AWG 14)	1.25 to 2 (AWG 16 to 14)	2 (AWG 14)	AWG 18 to 14
MR-J4-20B1-RJ020				
MR-J4-40B1-RJ020				



## 6. SELECTION EXAMPLE OF WIRES

### (2) Selection example of crimp terminals

Crimp terminal selection examples for the servo amplifier terminal blocks are indicated below.

#### (a) 200 V class

Symbol	Servo amplifier-side crimp terminals				Manufacturer
	(Note 2) Crimp terminal	Applicable tool			
		Body	Head	Dice	
a	FVD5.5-4	YNT-1210S			JST
b (Note 1)	8-4NS	YHT-8S			
c	FVD2-4	YNT-1614			
d	FVD2-M3				
e	FVD1.25-M3	YNT-2216			
f	FVD14-6	YF-1	YNE-38	DH-122 DH-112	
g	FVD5.5-6	YNT-1210S			
h	FVD22-6	YF-1	YNE-38	DH-123 DH-113	
i	FVD38-8	YF-1	YNE-38	DH-124 DH-114	
j	FVD5.5-8	YNT-1210S			
k	FVD8-6	YF-1/E-4	YNE-38	DH-121 DH-111	
l (Note 1)	38-S6	YPT-60-21		TD-124 TD-112	
		YF-1/E-4	YET-60-1	TD-124 TD-112	
m (Note 1)	R60-8 (Note 1)	YPT-60-21		TD-125 TD-113	
		YF-1/E-4	YET-60-1	TD-125 TD-113	

Note 1. Coat the crimping part with an insulation tube.

2. Some crimp terminals may not be mounted depending on their sizes. Make sure to use the recommended ones or equivalent ones.

#### (b) 400 V class

Symbol	Servo amplifier-side crimp terminals				Manufacturer	
	Crimp terminal (Note)	Applicable tool				
		Body	Head	Dice		
a	FVD5.5-4	YNT-1210S			JST	
b	FVD2-4	YNT-1614				
c	FVD2-M3					
d	FVD5.5-6	YNT-1210S				
e	FVD5.5-8	YNT-1210S				
f	FVD2-6	YNT-1614				
g	FVD8-6	YF-1	YNE-38	DH-121 DH-111		
h	FVD8-8					
i	FVD14-8					DH-122 DH-112
j	FVD22-6	YF-1/E-4	YNE-38	DH-113 DH-123		

Note. Some crimp terminals may not be mounted depending on their sizes. Make sure to use the recommended ones or equivalent ones.

## 6. SELECTION EXAMPLE OF WIRES

### 6.2 Converter unit/drive unit

The following shows cables used for wiring. Use the cable in this section or equivalent.

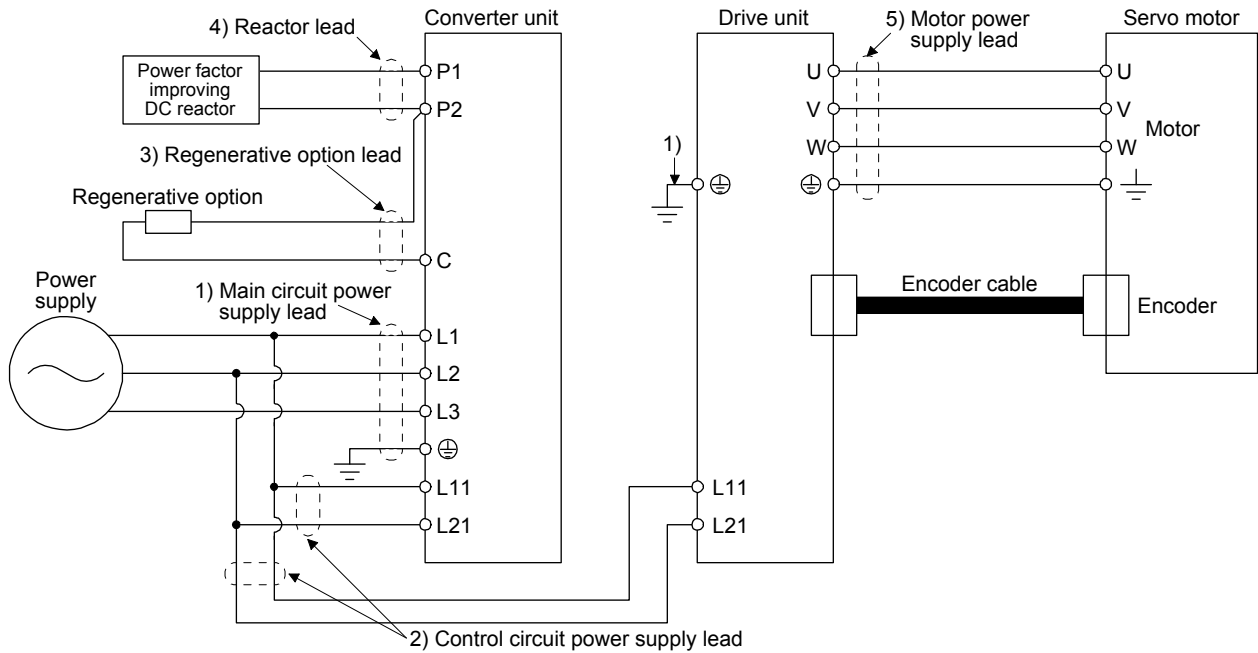

#### (1) Example of selecting the wire sizes

Use the 600 V grade heat-resistant polyvinyl chloride insulated wire (HIV wire) for wiring. The following shows the wire size selection example.

Converter unit (Note 2)	Drive unit (Note 2)	Wire [mm <sup>2</sup> ] (Note 1, 3)				
		1) L1/L2/L3/⊕	2) L11/L21	3) P2/C	4) P1/P2	5) U/V/W/⊕
MR-CR55K	MR-J4-DU30KB-RJ020	38 (AWG 2): b	1.25 to 2 (AWG 16 to 14): f (Note 4)	5.5 (AWG 10): a	60 (AWG 2/0): d	60 (AWG 2/0): c
	MR-J4-DU37KB-RJ020	60 (AWG 2/0): c			60 (AWG 2/0): d	60 (AWG 2/0): c
MR-CR55K4	MR-J4-DU30KB4-RJ020	22 (AWG 4): d			22 (AWG 4): e	30 (AWG 3): e
	MR-J4-DU37KB4-RJ020	22 (AWG 4): d			38 (AWG 2): f	38 (AWG 2): e
	MR-J4-DU45KB4-RJ020	38 (AWG 2): b	38 (AWG 2): c	50 (AWG 1/0): c		
	MR-J4-DU55KB4-RJ020	38 (AWG 2): b	38 (AWG 2): c	60 (AWG 2/0): c		

- Note
1. Alphabets in the table indicate crimping tools. For crimp terminals and applicable tools, refer to (2) in this section.
  2. To connect these models to a terminal block, be sure to use the screws that come with the terminal block.
  3. The wires are selected based on the largest rated current of the servo motors to be combined.
  4. Be sure to use the size of 2 mm<sup>2</sup> for compliance with the IEC/EN/UL/CSA standard.

## 6. SELECTION EXAMPLE OF WIRES

### (2) Selection example of crimp terminals

The following shows the selection example of crimp terminals for terminal blocks of the drive unit and converter unit when you use wires mentioned in (1) of this section.

Symbol	Drive unit/converter unit-side crimp terminals				Manufacturer
	(Note 2) Crimp terminal	Applicable tool			
		Body	Head	Dice	
a	FVD5.5-10	YNT-1210S			JST
(Note 1) b	R38-10	YPT-60-21		TD-124	
		YF-1 E-4	YET-60-1	TD-112	
(Note 1) c	R60-10	YPT-60-21		TD-125	
		YF-1 E-4	YET-60-1	TD-113	
d	FVD22-8	YF-1 E-4	YNE-38	DH-123 DH-113	
(Note 1) e	R38-8	YPT-60-21		TD-124	
		YF-1 E-4	YET-60-1	TD-112	
f	FVD2-4	YNT-1614			

- Note
1. Coat the crimping part with an insulation tube.
  2. Some crimp terminals may not be mounted depending on their sizes. Make sure to use the recommended ones or equivalent ones.

## 7. FULLY CLOSED LOOP SYSTEM

### 7. FULLY CLOSED LOOP SYSTEM

This chapter describes only the case where an HC series or HA series servo motor is used in the fully closed loop system. For items not given in this chapter, refer to chapter 15 of "MR-J4-(DU)\_B\_-RJ020 MR-J4-T20 Servo Amplifier Instruction Manual".

POINT
<ul style="list-style-type: none"> <li>● The fully closed loop system is enabled only in J2S compatibility mode.</li> <li>● For the fully closed loop system, use the servo amplifier or the drive unit with following software version:               <ul style="list-style-type: none"> <li>▪ A4 or later for 7 kW or less</li> <li>▪ A6 or later for 11 kW or more</li> </ul> </li> <li>● In the fully closed loop system, the following cable can be used for the servo motor encoder:               <ul style="list-style-type: none"> <li>▪ Two-wire type for software version A4 or later</li> <li>▪ Two-wire and four-wire types for software version A6 or later</li> </ul> </li> <li>● The fully closed loop system is available only in the position control mode.</li> <li>● When using the fully closed loop system, change the mode to "fully closed loop control mode" by using the application "MR-J4(W)-B mode selection" came with MR Configurator2.</li> </ul>

#### 7.1 System configuration

##### (1) For a linear encoder

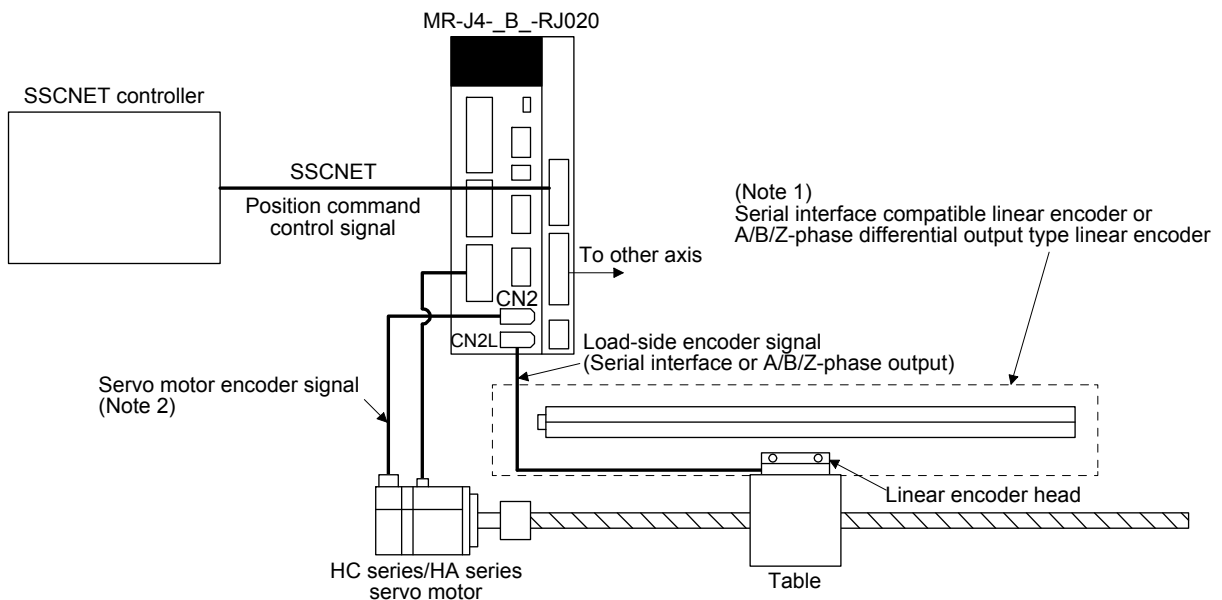

- Note 1. Applicable for the absolute position detection system when an absolute position linear encoder is used. In that case, a battery is not required. When an A/B/Z-phase differential output type linear encoder is used, the linear encoder without Z-phase cannot be connected. Not applicable for the absolute position detection system.
2. In the fully closed loop system, the following cable can be used for the servo motor encoder:
- Two-wire type for software version A4 or later
  - Two-wire and four-wire types for software version A6 or later

## 7. FULLY CLOSED LOOP SYSTEM

(2) For a rotary encoder

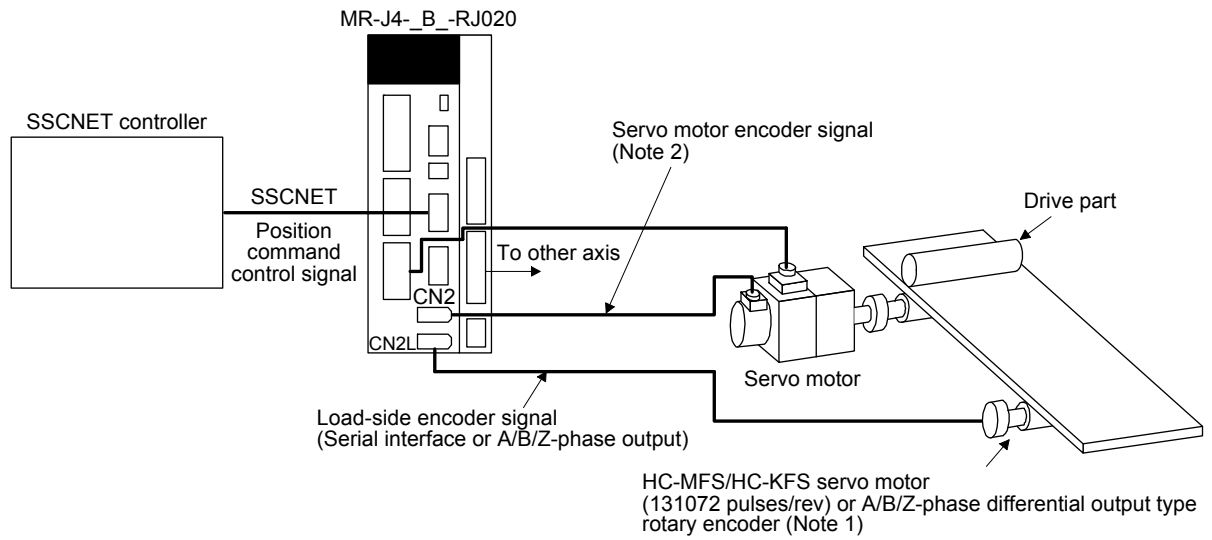

Note 1. Not applicable for the absolute position detection system.

Note 2. In the fully closed loop system, the following cable can be used for the servo motor encoder:

- Two-wire type for software version A4 or later
- Two-wire and four-wire types for software version A6 or later

### 7.2 Load-side encoder

POINT
● Always use the load-side encoder cable introduced in this section. Using other products may cause a malfunction.
● For details of the load-side encoder specifications, performance and assurance, contact each encoder manufacturer.

## 7. FULLY CLOSED LOOP SYSTEM

### 7.2.1 Linear encoder

<b>POINT</b>
<p>● For details of each linear encoder, refer to chapter 2 of "MR-J2S-_B-PY096 MR-J2S-_B-S096 (5.7kW) Instruction Manual".</p>

The following table shows compatible linear encoders.

Linear encoder type		Manufacturer	Model	Resolution	Rated speed (Note 1)	Effective measurement length (Maximum)	Communication method	Absolute position system
Mitsubishi serial interface compatible	Absolute position type	Mitutoyo	AT343A	0.05 μm	2.0 m/s	3,000 mm	Two-wire type	○
			AT543A			1,500 mm		
	Incremental type	Heidenhain	LC491M	0.05 μm	2.0 m/s	2,040 mm	Four-wire type	○
			Magnescale	SL710 + PL101R + MJ830	0.2 μm (Note 2)	6.4 m/s	3,000 mm	Two-wire type
		SH13 + MJ830		0.005 μm (Note 2)	1.4 m/s	1,240 mm	×	
		Renishaw		RGH26P	5.0 μm	4.0 m/s	70,000 mm	Two-wire type
			RGH26Q	1.0 μm	3.2 m/s	×		
RGH26R	0.5 μm		1.6 m/s	×				
A/B/Z-phase differential output type A/B/Z signal required (Note 3)	Incremental type	Not specified (Note 3)		Depends on the linear encoder (Note 4)	Depends on the linear encoder	Depends on the linear encoder	A/B/Z-phase differential output method	×

- Note
- The upper limit value of the linear servo motor speed is the lower value of the maximum speed of the linear servo motor and the rated speed of the linear encoder.
  - Changes depending on the setting of the interpolator.  
Set the resolution within a range of the minimum resolution to 5 μm.
  - The phase difference between the A-phase pulse and B-phase pulse must be 500 ns or more, and the Z-phase pulse width must be equivalent to one cycle of the A-phase pulse.  
Also, the Z-phase must be synchronized with the A-phase/B-phase.

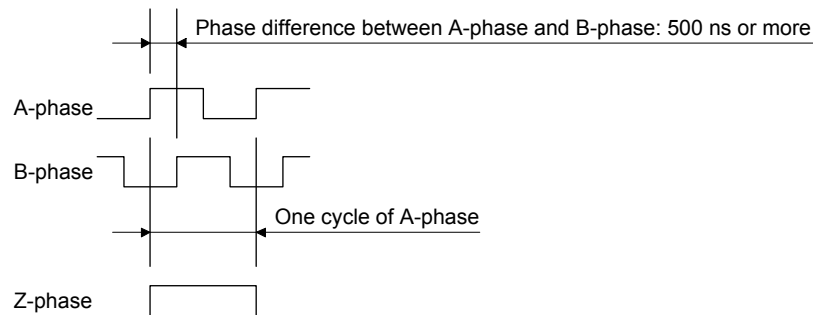

- The tolerable resolution range is between 0.005 μm and 5 μm. Please select a linear encoder within the range.

# 7. FULLY CLOSED LOOP SYSTEM

## 7.2.2 Rotary encoder

When a rotary encoder is used as a load-side encoder, use an HC-MFS or HC-KFS servo motor as the encoder. Two-wire type and four-wire type encoder cables can be used.

## 7.2.3 Configuration diagram of encoder cable

Configuration diagram for servo amplifier and load-side encoder is shown below. Cables vary depending on the load-side encoder.

### (1) Linear encoder

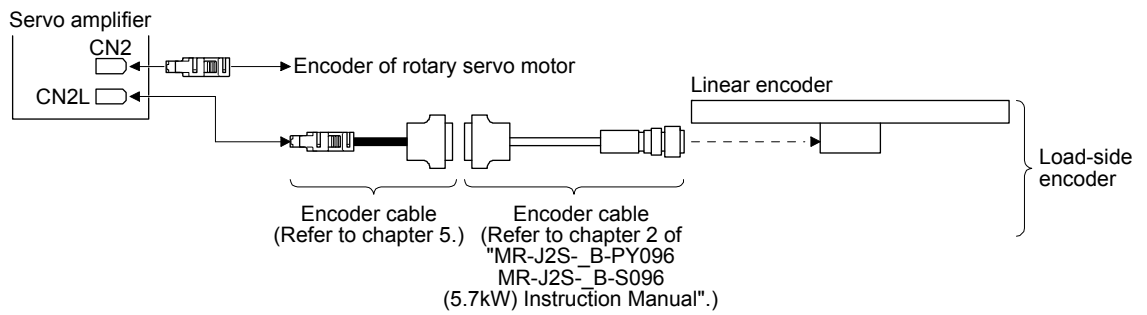

### (2) Rotary encoder

Refer to chapter 5 for the rotary encoder cable.

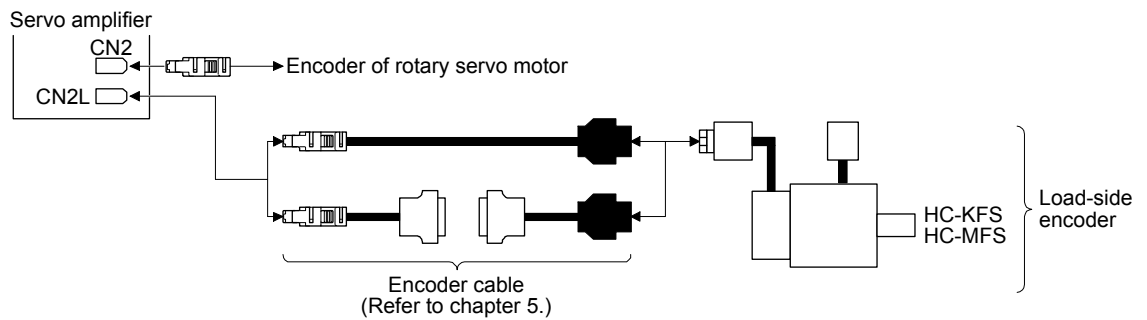

## REVISIONS

\*The manual number is given on the bottom left of the back cover.

Print Data	*Manual Number	Revision
Jun. 2013	SH(NA)030127-A	First edition
Aug. 2013	SH(NA)030127-B	<p>Safety Instructions are added</p> <p>Chapter 2 MR-J4-11KB(4)-RJ020 to MR-J4-22KB(4)-RJ020 are added.</p> <p>Section 3.1 Partially changed.</p> <p>Section 3.2 Partially added.</p> <p>Section 4.1 Servo motors for MR-J4-11KB(4)-RJ020 to MR-J4-22KB(4)-RJ020 are added.</p> <p>Section 4.2 MR-J4-11KB(4)-RJ020 to MR-J4-22KB(4)-RJ020 are added.</p> <p>Section 4.3 Servo motors for MR-J4-11KB(4)-RJ020 to MR-J4-22KB(4)-RJ020 are added.</p> <p>Section 4.5 MR-J4-11KB(4)-RJ020 to MR-J4-22KB(4)-RJ020 are added.</p> <p>Section 5.4 Regenerative options for MR-J4-11KB(4)-RJ020 to MR-J4-22KB(4)-RJ020 are added.</p> <p>Chapter 6 MR-J4-11KB(4)-RJ020 to MR-J4-22KB(4)-RJ020 are added.</p>
Mar. 2014	SH(NA)030127-C	<p>100 V class MR-J4 series servo amplifiers are added.</p> <p>«About the manual» Partially changed.</p> <p>Chapter 2 (3) is added.</p> <p>Section 3.2 (2) (b) is added.</p> <p>Section 3.2 (4) is added.</p> <p>Section 4.1 The part of table is changed.</p> <p>Section 4.2 The part of table is changed.</p> <p>Section 4.3 (2) The table is changed.</p> <p>Section 4.5 POINT is added.</p> <p>Section 4.5 (3) is added.</p> <p>Section 5.4 (1) (c) is added.</p> <p>Section 5.4 (1) (b) The part of table is changed.</p> <p>Section 5.4 (3) The setting value of [Pr. 2] is added.</p> <p>Chapter 6 (1) (c) is added.</p>
Sep. 2015	SH(NA)030127-D	<p>Large capacities and fully closed loop system (7 kW or less) are added.</p> <p>Front cover The title is changed.</p> <p>Safety Instructions Partially changed.</p> <p>Relevant manuals Partially changed.</p> <p>Chapter 2 The description of large capacities (MR-J4-DU30KB(4)-RJ020 to MR-J4-DU55KB4-RJ020) is added.</p> <p>Chapter 3 The description of large capacities (MR-J4-DU30KB(4)-RJ020 to MR-J4-DU55KB4-RJ020) is added.</p> <p>Chapter 4 The description of large capacities (MR-J4-DU30KB(4)-RJ020 to MR-J4-DU55KB4-RJ020) is added.</p> <p>Section 4.1 The characteristics are added.</p> <p>Chapter 5 The description of large capacities (MR-J4-DU30KB(4)-RJ020 to MR-J4-DU55KB4-RJ020) is added.</p> <p>Chapter 6 The description of large capacities (MR-J4-DU30KB(4)-RJ020 to MR-J4-DU55KB4-RJ020) is added.</p> <p>Chapter 7 Newly added.</p>
Mar. 2016	SH(NA)030127-E	<p>Software version A6 and fully closed loop control system (11 kW or more) are added.</p> <p>4. Additional instructions Partially changed</p> <p>Section 5.3 Partially changed</p> <p>Chapter 6 Contents of 11 kW or more are added.</p>

This manual confers no industrial property rights or any rights of any other kind, nor does it confer any patent licenses. Mitsubishi Electric Corporation cannot be held responsible for any problems involving industrial property rights which may occur as a result of using the contents noted in this manual.





Country/Region	Sales office	Tel/Fax
USA	Mitsubishi Electric Automation, Inc. 500 Corporate Woods Parkway, Vernon Hills, IL 60061, U.S.A.	Tel : +1-847-478-2100 Fax : +1-847-478-2253
Mexico	Mitsubishi Electric Automation, Inc. Mexico Branch Mariano Escobedo #69, Col. Zona Industrial, Tlalnepantla Edo. Mexico, C.P.54030	Tel : +52-55-3067-7500 Fax : -
Brazil	Mitsubishi Electric do Brasil Comercio e Servicos Ltda. Avenida Adelino Cardana, 293, 21 andar, Bethaville, CEP 06401-147, Barueri SP, Brazil	Tel : +55-11-4689-3000 Fax : +55-11-4689-3016
Germany	Mitsubishi Electric Europe B.V. German Branch Mitsubishi-Electric-Platz 1, 40882 Ratingen, Germany	Tel : +49-2102-486-0 Fax : +49-2102-486-1120
UK	Mitsubishi Electric Europe B.V. UK Branch Travellers Lane, UK-Hatfield, Hertfordshire, AL10 8XB, U.K.	Tel : +44-1707-28-8780 Fax : +44-1707-27-8695
Italy	Mitsubishi Electric Europe B.V. Italian Branch Centro Direzionale Colleoni - Palazzo Sirio, Viale Colleoni 7, 20864 Agrate Brianza (Milano), Italy	Tel : +39-039-60531 Fax : +39-039-6053-312
Spain	Mitsubishi Electric Europe B.V. Spanish Branch Carretera de Rubi, 76-80-Apdo. 420, 08190 Sant Cugat del Valles (Barcelona), Spain	Tel : +34-935-65-3131 Fax : +34-935-89-1579
France	Mitsubishi Electric Europe B.V. French Branch 25, Boulevard des Bouvets, 92741 Nanterre Cedex, France	Tel : +33-1-55-68-55-68 Fax : +33-1-55-68-57-57
Czech Republic	Mitsubishi Electric Europe B.V. Czech Branch Avenir Business Park, Radlicka 751/113e, 158 00 Praha 5, Czech Republic	Tel : +420-251-551-470 Fax : +420-251-551-471
Poland	Mitsubishi Electric Europe B.V. Polish Branch ul. Krakowska 50, 32-083 Balice, Poland	Tel : +48-12-347-65-00 Fax : +48-12-630-47-01
Russia	Mitsubishi Electric (Russia) LLC St. Petersburg Branch Piskarevsky pr. 2, bld 2, lit "Sch", BC "Benua", office 720; 195027 St. Petersburg, Russia	Tel : +7-812-633-3497 Fax : +7-812-633-3499
Sweden	Mitsubishi Electric Europe B.V. (Scandinavia) Fjelievagen 8, SE-22736 Lund, Sweden	Tel : +46-8-625-10-00 Fax : +46-46-39-70-18
Turkey	Mitsubishi Electric Turkey A.S. Umraniye Branch Serifali Mahallesi Nutuk Sokak No:5, TR-34775 Umraniye / Istanbul, Turkey	Tel : +90-216-526-3990 Fax : +90-216-526-3995
UAE	Mitsubishi Electric Europe B.V. Dubai Branch Dubai Silicon Oasis, P.O.BOX 341241, Dubai, U.A.E.	Tel : +971-4-3724716 Fax : +971-4-3724721
South Africa	Adroit Technologies 20 Waterford Office Park, 189 Witkoppen Road, Fourways, South Africa	Tel : +27-11-658-8100 Fax : +27-11-658-8101
China	Mitsubishi Electric Automation (China) Ltd. Mitsubishi Electric Automation Center, No.1386 Hongqiao Road, Shanghai, China	Tel : +86-21-2322-3030 Fax : +86-21-2322-3000
Taiwan	SETSUYO ENTERPRISE CO., LTD. 6F, No.105, Wugong 3rd Road, Wugu District, New Taipei City 24889, Taiwan	Tel : +886-2-2299-2499 Fax : +886-2-2299-2509
Korea	Mitsubishi Electric Automation Korea Co., Ltd. 7F-9F, Gangseo Hangang Xi-tower A, 401, Yangcheon-ro, Gangseo-Gu, Seoul 07528, Korea	Tel : +82-2-3660-9510 Fax : +82-2-3664-8372/8335
Singapore	Mitsubishi Electric Asia Pte. Ltd. 307 Alexandra Road, Mitsubishi Electric Building, Singapore 159943	Tel : +65-6473-2308 Fax : +65-6476-7439
Thailand	Mitsubishi Electric Factory Automation (Thailand) Co., Ltd. 12th Floor, SV.City Building, Office Tower 1, No. 896/19 and 20 Rama 3 Road, Kwaeng Bangpongpan, Khet Yannawa, Bangkok 10120, Thailand	Tel : +66-2682-6522 to 6531 Fax : +66-2682-6020
Indonesia	PT. Mitsubishi Electric Indonesia Gedung Jaya 11th Floor, JL. MH. Thamrin No.12, Jakarta Pusat 10340, Indonesia	Tel : +62-21-3192-6461 Fax : +62-21-3192-3942
Vietnam	Mitsubishi Electric Vietnam Company Limited Unit 01-04, 10th Floor, Vincom Center, 72 Le Thanh Ton Street, District 1, Ho Chi Minh City, Vietnam	Tel : +84-8-3910-5945 Fax : +84-8-3910-5947
India	Mitsubishi Electric India Pvt. Ltd. Pune Branch Emerald House, EL-3, J Block, M.I.D.C., Bhosari, Pune - 411026, Maharashtra, India	Tel : +91-20-2710-2000 Fax : +91-20-2710-2100
Australia	Mitsubishi Electric Australia Pty. Ltd. 348 Victoria Road, P.O. Box 11, Rydalmere, N.S.W 2116, Australia	Tel : +61-2-9684-7777 Fax : +61-2-9684-7245

MELSERVO is a trademark or registered trademark of Mitsubishi Electric Corporation in Japan and/or other countries.  
All other product names and company names are trademarks or registered trademarks of their respective companies.

## Warranty

### 1. Warranty period and coverage

We will repair any failure or defect hereinafter referred to as "failure" in our FA equipment hereinafter referred to as the "Product" arisen during warranty period at no charge due to causes for which we are responsible through the distributor from which you purchased the Product or our service provider. However, we will charge the actual cost of dispatching our engineer for an on-site repair work on request by customer in Japan or overseas countries. We are not responsible for any on-site readjustment and/or trial run that may be required after a defective unit are repaired or replaced.

### [Term]

The term of warranty for Product is twelve (12) months after your purchase or delivery of the Product to a place designated by you or eighteen (18) months from the date of manufacture whichever comes first ("Warranty Period"). Warranty period for repaired Product cannot exceed beyond the original warranty period before any repair work.

### [Limitations]

- (1) You are requested to conduct an initial failure diagnosis by yourself, as a general rule.  
It can also be carried out by us or our service company upon your request and the actual cost will be charged. However, it will not be charged if we are responsible for the cause of the failure.
- (2) This limited warranty applies only when the condition, method, environment, etc. of use are in compliance with the terms and conditions and instructions that are set forth in the instruction manual and user manual for the Product and the caution label affixed to the Product.
- (3) Even during the term of warranty, the repair cost will be charged on you in the following cases;
  - (i) a failure caused by your improper storing or handling, carelessness or negligence, etc., and a failure caused by your hardware or software problem
  - (ii) a failure caused by any alteration, etc. to the Product made on your side without our approval
  - (iii) a failure which may be regarded as avoidable, if your equipment in which the Product is incorporated is equipped with a safety device required by applicable laws and has any function or structure considered to be indispensable according to a common sense in the industry
  - (iv) a failure which may be regarded as avoidable if consumable parts designated in the instruction manual, etc. are duly maintained and replaced
  - (v) any replacement of consumable parts (battery, fan, smoothing capacitor, etc.)
  - (vi) a failure caused by external factors such as inevitable accidents, including without limitation fire and abnormal fluctuation of voltage, and acts of God, including without limitation earthquake, lightning and natural disasters
  - (vii) a failure generated by an unforeseeable cause with a scientific technology that was not available at the time of the shipment of the Product from our company
  - (viii) any other failures which we are not responsible for or which you acknowledge we are not responsible for

### 2. Term of warranty after the stop of production

- (1) We may accept the repair at charge for another seven (7) years after the production of the product is discontinued. The announcement of the stop of production for each model can be seen in our Sales and Service, etc.
- (2) Please note that the Product (including its spare parts) cannot be ordered after its stop of production.

### 3. Service in overseas countries

Our regional FA Center in overseas countries will accept the repair work of the Product. However, the terms and conditions of the repair work may differ depending on each FA Center. Please ask your local FA center for details.

### 4. Exclusion of loss in opportunity and secondary loss from warranty liability

Regardless of the gratis warranty term, Mitsubishi shall not be liable for compensation to:

- (1) Damages caused by any cause found not to be the responsibility of Mitsubishi.
- (2) Loss in opportunity, lost profits incurred to the user by Failures of Mitsubishi products.
- (3) Special damages and secondary damages whether foreseeable or not, compensation for accidents, and compensation for damages to products other than Mitsubishi products.
- (4) Replacement by the user, maintenance of on-site equipment, start-up test run and other tasks.

### 5. Change of Product specifications

Specifications listed in our catalogs, manuals or technical documents may be changed without notice.

### 6. Application and use of the Product

- (1) For the use of our General-Purpose AC Servo, its applications should be those that may not result in a serious damage even if any failure or malfunction occurs in General-Purpose AC Servo, and a backup or fail-safe function should operate on an external system to General-Purpose AC Servo when any failure or malfunction occurs.
- (2) Our General-Purpose AC Servo is designed and manufactured as a general purpose product for use at general industries. Therefore, applications substantially influential on the public interest for such as atomic power plants and other power plants of electric power companies, and also which require a special quality assurance system, including applications for railway companies and government or public offices are not recommended, and we assume no responsibility for any failure caused by these applications when used  
In addition, applications which may be substantially influential to human lives or properties for such as airlines, medical treatments, railway service, incineration and fuel systems, man-operated material handling equipment, entertainment machines, safety machines, etc. are not recommended, and we assume no responsibility for any failure caused by these applications when used. We will review the acceptability of the abovementioned applications, if you agree not to require a specific quality for a specific application. Please contact us for consultation.

MODEL	INSTRUCTIONS FOR HC/HA WITH J4-B-RJ020
MODEL CODE	1CW815

# MITSUBISHI ELECTRIC CORPORATION

HEAD OFFICE : TOKYO BLDG MARUNOUCHI TOKYO 100-8310