



General-Purpose AC Servo

MITSUBISHI SERVO AMPLIFIERS & MOTORS
MELSERVO-J4

General-Purpose Interface Drive Unit

MODEL

MR-J4-DU_A_(-RJ)

SSCNET III/H Interface Drive Unit

MODEL

MR-J4-DU_B_(-RJ)

Converter Unit

MODEL

MR-CR55K_

INSTRUCTION MANUAL

● Safety Instructions ●

Please read the instructions carefully before using the equipment.

To use the equipment correctly, do not attempt to install, operate, maintain, or inspect the equipment until you have read through this Instruction Manual, Installation guide, and appended documents carefully. Do not use the equipment until you have a full knowledge of the equipment, safety information and instructions. In this Instruction Manual, the safety instruction levels are classified into "WARNING" and "CAUTION".



Indicates that incorrect handling may cause hazardous conditions, resulting in death or severe injury.



Indicates that incorrect handling may cause hazardous conditions, resulting in medium or slight injury to personnel or may cause physical damage.

Note that the  CAUTION level may lead to a serious consequence according to conditions. Please follow the instructions of both levels because they are important to personnel safety. What must not be done and what must be done are indicated by the following diagrammatic symbols.



Indicates what must not be done. For example, "No Fire" is indicated by .



Indicates what must be done. For example, grounding is indicated by .

In this Instruction Manual, instructions at a lower level than the above, instructions for other functions, and so on are classified into "POINT".

After reading this Instruction Manual, keep it accessible to the operator.

1. To prevent electric shock, note the following.

WARNING

- Before wiring or inspection, turn off the power and wait for 20 minutes or more until the charge lamp turns off. Then, confirm that the voltage between L+ and L- is safe with a voltage tester and others. Otherwise, an electric shock may occur. In addition, always confirm whether the charge lamp is off or not from the front of the converter unit.
- Ground the converter unit, the drive unit, and the servo motor securely.
- Any person who is involved in wiring and inspection should be fully competent to do the work.
- Do not attempt to wire the converter unit, the drive unit, and the servo motor until they have been installed. Otherwise, it may cause an electric shock.
- Do not operate switches with wet hands. Otherwise, it may cause an electric shock.
- The cables should not be damaged, stressed, loaded, or pinched. Otherwise, it may cause an electric shock.
- During power-on or operation, do not open the front cover of the converter unit and the drive unit. Otherwise, it may cause an electric shock.
- Do not operate the converter unit and the drive unit with the front cover removed. High-voltage terminals and charging area are exposed and you may get an electric shock.
- Except for wiring or periodic inspection, do not remove the front cover of the converter unit and the drive unit even if the power is off. The converter unit and the drive unit are charged and you may get an electric shock.
- To prevent an electric shock, always connect the protective earth (PE) terminal (marked \oplus) of the converter unit and the drive unit to the protective earth (PE) of the cabinet.
- To avoid an electric shock, insulate the connections of the power supply terminals.

2. To prevent fire, note the following.

CAUTION

- Install the converter unit, the drive unit, the servo motor, and the regenerative resistor on incombustible material. Installing them directly or close to combustibles will lead to smoke or a fire.
- Always connect the magnetic contactor between the power supply and the main circuit power supply (L1, L2, and L3) of the converter unit, in order to configure a circuit that shuts down the power supply on the side of the converter unit power supply. If a magnetic contactor is not connected, continuous flow of a large current may cause smoke or a fire when the converter unit or the drive unit malfunctions.
- Always connect a molded-case circuit breaker, or a fuse to each converter unit between the power supply and the main circuit power supply (L1, L2, and L3) of the converter unit, in order to configure a circuit that shuts down the power supply on the side of the converter unit's power supply. If a molded-case circuit breaker or fuse is not connected, continuous flow of a large current may cause smoke or a fire when the converter unit malfunctions.
- When using a regenerative resistor, switch power off with the alarm signal. Otherwise, a regenerative transistor malfunction or the like may overheat the regenerative resistor, causing smoke or a fire.
- Provide adequate protection to prevent screws and other conductive matter, oil and other combustible matter from entering the converter unit, the drive unit, and the servo motor.

3. To prevent injury, note the following.

 CAUTION	
<ul style="list-style-type: none"> ● Only the voltage specified in the Instruction Manual should be applied to each terminal. Otherwise, a burst, damage, etc. may occur. ● Connect cables to the correct terminals. Otherwise, a burst, damage, etc. may occur. ● Ensure that polarity (+/-) is correct. Otherwise, a burst, damage, etc. may occur. ● The heat sink of the converter unit and the drive unit, the regenerative resistor, the servo motor, etc. may be hot while power is on or for some time after power-off. Take safety measures, e.g. provide covers, to avoid accidentally touching the parts (cables, etc.) by hand. 	

4. Additional instructions

The following instructions should also be fully noted. Incorrect handling may cause a malfunction, injury, electric shock, fire, etc.

(1) Transportation and installation

 CAUTION															
<ul style="list-style-type: none"> ● Transport the products correctly according to their mass. ● Stacking in excess of the specified number of product packages is not allowed. ● Do not hold the front cover to transport the converter unit and the drive unit. Otherwise, they may drop. ● Install the converter unit, the drive unit, and the servo motor in a load-bearing place in accordance with the Instruction Manual. ● Do not get on or put heavy load on the equipment. ● The equipment must be installed in the specified direction. ● Leave the specified clearances between the converter unit/drive unit and the cabinet walls or other equipment. ● Do not install or operate the converter unit, the drive unit, and the servo motor which have been damaged or have any parts missing. ● Do not block the intake and exhaust areas of the converter unit and the drive unit. Otherwise, it may cause a malfunction. ● Do not drop or strike the converter unit, the drive unit, and the servo motor as they are precision equipment. ● When you keep or use the equipment, please fulfill the following environment. 															
<table border="1" style="width: 100%; border-collapse: collapse;"> <thead> <tr> <th style="width: 20%;">Item</th> <th style="width: 80%;">Environment</th> </tr> </thead> <tbody> <tr> <td rowspan="2">Ambient temperature</td> <td>Operation: 0 °C to 55 °C (non-freezing)</td> </tr> <tr> <td>Storage: -20 °C to 65 °C (non-freezing)</td> </tr> <tr> <td rowspan="2">Ambient humidity</td> <td>Operation: 90 %RH or less (non-condensing)</td> </tr> <tr> <td>Storage: 90 %RH or less (non-condensing)</td> </tr> <tr> <td>Ambience</td> <td>Indoors (no direct sunlight); no corrosive gas, inflammable gas, oil mist or dust</td> </tr> <tr> <td>Altitude</td> <td>2000 m or less above sea level (Contact your local sales office for the altitude for options.)</td> </tr> <tr> <td>Vibration resistance</td> <td>5.9 m/s², at 10 Hz to 55 Hz (directions of X, Y and Z axes)</td> </tr> </tbody> </table>		Item	Environment	Ambient temperature	Operation: 0 °C to 55 °C (non-freezing)	Storage: -20 °C to 65 °C (non-freezing)	Ambient humidity	Operation: 90 %RH or less (non-condensing)	Storage: 90 %RH or less (non-condensing)	Ambience	Indoors (no direct sunlight); no corrosive gas, inflammable gas, oil mist or dust	Altitude	2000 m or less above sea level (Contact your local sales office for the altitude for options.)	Vibration resistance	5.9 m/s ² , at 10 Hz to 55 Hz (directions of X, Y and Z axes)
Item	Environment														
Ambient temperature	Operation: 0 °C to 55 °C (non-freezing)														
	Storage: -20 °C to 65 °C (non-freezing)														
Ambient humidity	Operation: 90 %RH or less (non-condensing)														
	Storage: 90 %RH or less (non-condensing)														
Ambience	Indoors (no direct sunlight); no corrosive gas, inflammable gas, oil mist or dust														
Altitude	2000 m or less above sea level (Contact your local sales office for the altitude for options.)														
Vibration resistance	5.9 m/s ² , at 10 Hz to 55 Hz (directions of X, Y and Z axes)														
<ul style="list-style-type: none"> ● When the equipment has been stored for an extended period of time, contact your local sales office. ● When handling the converter unit and the drive unit, be careful about the edged parts such as the corners of the converter unit and drive unit. ● The converter unit and the drive unit must be installed in a metal cabinet. ● When fumigants that contain halogen materials, such as fluorine, chlorine, bromine, and iodine, are used for disinfecting and protecting wooden packaging from insects, they cause malfunction when entering our products. Please take necessary precautions to ensure that remaining materials from fumigant do not enter our products, or treat packaging with methods other than fumigation, such as heat treatment. Additionally, disinfect and protect wood from insects before packing the products. 															

(2) Wiring

⚠ CAUTION

- Wire the equipment correctly and securely. Otherwise, the servo motor may operate unexpectedly.
- Do not install a power capacitor, surge killer, or radio noise filter (optional FR-BIF-(H)) on the drive unit output side.
- To avoid a malfunction of the servo motor, connect the wires to the correct phase terminals (U, V, and W) of the drive unit and the servo motor.
- Connect the drive unit power outputs (U, V, and W) to the servo motor power inputs (U, V, and W) directly. Do not let a magnetic contactor, etc. intervene. Otherwise, it may cause a malfunction.

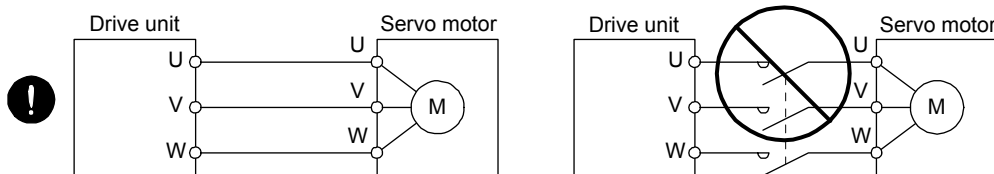

- The connection diagrams in this Instruction Manual are shown for sink interfaces, unless stated otherwise.
- Install the surge absorbing diode to the DC relay for control output signals in the converter unit and the drive unit in the specified direction. Otherwise, the emergency stop and other protective circuits may not operate.

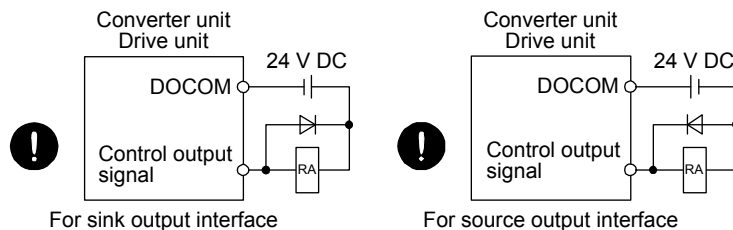

- When the cable is not tightened enough to the terminal block, the cable or terminal block may generate heat because of the poor contact. Be sure to tighten the cable with specified torque.
- Do not connect the servo motor of a wrong axis to U, V, W, or CN2 of the drive unit. Otherwise, a malfunction may occur.

(3) Test run and adjustment

⚠ CAUTION

- Before operation, check and adjust the parameter settings. Improper settings may cause some machines to operate unexpectedly.
- Never make a drastic adjustment or change to the parameter values as doing so will make the operation unstable.
- Do not get close to moving parts during the servo-on status.

(4) Usage

⚠ CAUTION

- When it is assumed that a hazardous condition may occur due to a power failure or product malfunction, use a servo motor with an external brake to prevent the condition.
- Do not disassemble, repair, or modify the equipment.
- Before resetting an alarm, make sure that the run signal of the drive unit is off to prevent a sudden restart. Otherwise, it may cause an accident.
- Use a noise filter, etc. to minimize the influence of electromagnetic interference. Electromagnetic interference may be given to the electronic equipment used near the converter unit and the drive unit.
- Burning or breaking the converter unit and the drive unit may cause a toxic gas. Do not burn or break the converter unit and the drive unit.
- Use the converter unit and the drive unit with the specified servo motor.
- The electromagnetic brake on the servo motor is designed to hold the motor shaft and should not be used for ordinary braking.
- For such reasons as service life and mechanical structure (e.g. where a ball screw and the servo motor are coupled via a timing belt), the electromagnetic brake may not hold the motor shaft. To ensure safety, install a stopper on the machine side.

(5) Corrective actions

⚠ CAUTION

- When it is assumed that a hazardous condition may occur due to a power failure or product malfunction, use a servo motor with an electromagnetic brake, or an external brake to prevent the condition.
- Configure an electromagnetic brake circuit so that it is activated also by an external emergency stop switch.

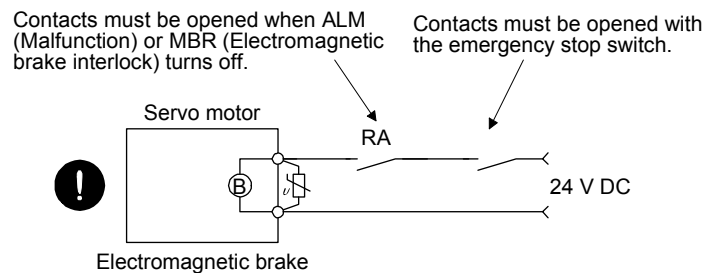

- When any alarm has occurred, eliminate its cause, ensure safety, and deactivate the alarm before restarting operation.
- Provide an adequate protection to prevent unexpected restart after an instantaneous power failure.

(6) Maintenance, inspection and parts replacement

CAUTION

- With age, the electrolytic capacitor of the converter unit and the drive unit will deteriorate. To prevent a secondary accident due to a malfunction, it is recommended that the electrolytic capacitor be replaced every 10 years when it is used in general environment. Please contact your local sales office for replacement.
- When using a converter unit or the drive unit whose power has not been turned on for a long time, contact your local sales office.

(7) General instruction

- To illustrate details, the equipment in the diagrams of this Instruction Manual may have been drawn without covers and safety guards. When the equipment is operated, the covers and safety guards must be installed as specified. Operation must be performed in accordance with this Instruction Manual.

● DISPOSAL OF WASTE ●

Please dispose a converter unit, drive unit, battery (primary battery) and other options according to your local laws and regulations.



EEP-ROM life

The number of write times to the EEPROM, which stores parameter settings, etc., is limited to 100,000. If the total number of the following operations exceeds 100,000, the converter unit or the drive unit may malfunction when the EEPROM reaches the end of its useful life.

- Write to the EEPROM due to parameter setting changes
- Write to the EEPROM due to device changes
- Home position setting in the absolute position detection system (MR-J4-DU_A_(-RJ))

STO function of the drive unit

When using the STO function of the drive unit, refer to chapter 13 of "MR-J4-_A_(-RJ) Servo Amplifier Instruction Manual" or "MR-J4-_B_(-RJ) Servo Amplifier Instruction Manual".

For the MR-J3-D05 safety logic unit, refer to appendix 5 of "MR-J4-_A_(-RJ) Servo Amplifier Instruction Manual" or "MR-J4-_B_(-RJ) Servo Amplifier Instruction Manual".

Compliance with global standards

Refer to appendix 2 for the compliance with global standards.

«About the manual»

You must have this Instruction Manual and the following manuals to use this servo. Ensure to prepare them to use the servo safely.

Relevant manuals

Manual name	Manual No.
MR-J4-_A(-RJ) Servo Amplifier Instruction Manual (Note 1)	SH(NA)030107
MR-J4-_B(-RJ) Servo Amplifier Instruction Manual (Note 2)	SH(NA)030106
MR-J4-_A_-RJ Servo Amplifier Instruction Manual (Positioning Mode) (Note 4)	SH(NA)030143
MELSERVO MR-J4-_A_-RJ Servo Amplifier Instruction Manual (Modbus-RTU Protocol) (Note 5)	SH(NA)030175
MR-J4 Servo Amplifier Instruction Manual (Troubleshooting)	SH(NA)030109
MELSERVO Servo Motor Instruction Manual (Vol. 3)	SH(NA)030113
MELSERVO Linear Encoder Instruction Manual (Note 3)	SH(NA)030111
EMC Installation Guidelines	IB(NA)67310

- Note
1. It is necessary for using an MR-J4-DU_A_(-RJ) drive unit.
 2. It is necessary for using an MR-J4-DU_B_(-RJ) drive unit.
 3. It is necessary for using a fully closed loop system.
 4. It is necessary for using an MR-J4-DU_A_-RJ drive unit in the positioning mode.
 5. It is necessary for using a Modbus-RTU communication function.

This Instruction Manual does not describe the following items. The followings are the same as those for MR-J4-_-(-RJ). For the details of the items, refer to each chapter/section indicated in the detailed explanation field. "MR-J4-_A_" means "MR-J4-_A_(-RJ) Servo Amplifier Instruction Manual". "MR-J4-_B_" means "MR-J4-_B_(-RJ) Servo Amplifier Instruction Manual".

Model	Item	Detailed explanation
MR-J4-DU_A_(-RJ)	NORMAL GAIN ADJUSTMENT	MR-J4-_A_ chapter 6
	SPECIAL ADJUSTMENT FUNCTIONS (Note)	MR-J4-_A_ chapter 7
	ABSOLUTE POSITION DETECTION SYSTEM	MR-J4-_A_ chapter 12
	USING STO FUNCTION	MR-J4-_A_ chapter 13
	COMMUNICATION FUNCTION (Mitsubishi general-purpose AC servo protocol)	MR-J4-_A_ chapter 14
	FULLY CLOSED LOOP SYSTEM	MR-J4-_A_ chapter 17
MR-J4-DU_B_(-RJ)	NORMAL GAIN ADJUSTMENT	MR-J4-_B_ chapter 6
	SPECIAL ADJUSTMENT FUNCTIONS (Note)	MR-J4-_B_ chapter 7
	ABSOLUTE POSITION DETECTION SYSTEM	MR-J4-_B_ chapter 12
	USING STO FUNCTION	MR-J4-_B_ chapter 13
	FULLY CLOSED LOOP SYSTEM	MR-J4-_B_ chapter 16
	APPLICATION OF FUNCTIONS	MR-J4-_B_ chapter 17

Note. Refer to chapter 10 in this Instruction Manual for the compatibility with the SEMI-F47 standard.

«Cables used for wiring»

Wires mentioned in this Instruction Manual are selected based on an ambient temperature of 40 °C.

«U.S. customary units»

U.S. customary units are not shown in this manual. Convert the values if necessary according to the following table.

Quantity	SI (metric) unit	U.S. customary unit
Mass	1 [kg]	2.2046 [lb]
Length	1 [mm]	0.03937 [inch]
Torque	1 [N•m]	141.6 [oz•inch]
Moment of inertia	1 [($\times 10^{-4}$ kg•m ²)]	5.4675 [oz•inch ²]
Load (thrust load/axial load)	1 [N]	0.2248 [lbf]
Temperature	N [$^{\circ}$ C] \times 9/5 + 32	N [$^{\circ}$ F]

«Contents of the package»

Unpack the converter unit and the drive unit, and check the rating plates to see if the units are as you ordered.

(1) Converter unit

Contents	Quantity
Converter unit	1
Eyebolt	2
Magnetic contactor wiring connector	1
Digital I/O connector	1
MELSERVO-J4 Series Instructions and Cautions for Safe Use of AC Servos	1

(2) Drive unit

Contents	Quantity
Drive unit	1
Bus bar	2
Eyebolt	2
MELSERVO-J4 Series Instructions and Cautions for Safe Use of AC Servos	1

CONTENTS

1. FUNCTIONS AND CONFIGURATION	1- 1 to 1-30
1.1 Function block diagram.....	1- 2
1.1.1 MR-J4-DU_A_(-RJ).....	1- 2
1.1.2 MR-J4-DU_B_(-RJ).....	1- 4
1.2 Standard specifications.....	1- 6
1.2.1 Converter unit.....	1- 6
1.2.2 Drive unit.....	1- 7
1.3 Combinations of converter units, drive units and servo motors.....	1-15
1.4 Model designation.....	1-15
1.5 Structure.....	1-17
1.5.1 Parts identification.....	1-17
1.5.2 Opening and closing of the terminal block cover.....	1-25
1.6 Configuration including peripheral equipment.....	1-29
2. INSTALLATION	2- 1 to 2- 6
2.1 Installation direction and clearances.....	2- 2
2.2 Keeping out of foreign materials.....	2- 4
2.3 Inspection items.....	2- 4
2.4 Parts having service lives.....	2- 5
2.5 Restrictions when using the servo amplifiers at altitude exceeding 1000 m and up to 2000 m over sea level.....	2- 6
3. SIGNALS AND WIRING	3- 1 to 3-38
3.1 Input power supply circuit.....	3- 2
3.1.1 Magnetic contactor control connector (CNP1).....	3- 3
3.1.2 Wiring diagram.....	3- 5
3.1.3 How to use the bus bars.....	3-13
3.2 Explanation of power supply system.....	3-14
3.2.1 Signal explanations.....	3-14
3.2.2 Power-on sequence.....	3-15
3.3 Connectors and pin assignment.....	3-19
3.3.1 Converter unit.....	3-19
3.3.2 Drive unit.....	3-20
3.4 Signal (device) explanations.....	3-22
3.5 Alarm occurrence timing chart.....	3-23
3.5.1 MR-J4-DU_A_(-RJ).....	3-23
3.5.2 MR-J4-DU_B_(-RJ).....	3-27
3.5.3 Forced stop in the converter unit.....	3-31
3.6 Interfaces.....	3-35
3.6.1 Detailed explanation of interfaces.....	3-35
3.6.2 Source I/O interfaces.....	3-36
3.7 Grounding.....	3-37

4. STARTUP	4- 1 to 4-14
-------------------	---------------------

4.1	Switching power on for the first time.....	4- 2
4.1.1	Startup procedure	4- 2
4.1.2	Wiring check.....	4- 4
4.2	Startup	4- 7
4.2.1	MR-J4-DU_A_(-RJ).....	4- 7
4.2.2	MR-J4-DU_B_(-RJ).....	4- 7
4.3	Display and operation section of the converter unit	4- 8
4.3.1	Display flowchart	4- 8
4.3.2	Status display mode.....	4- 9
4.3.3	Diagnostic mode	4-10
4.3.4	Alarm mode	4-12
4.3.5	Parameter mode	4-13

5. PARAMETERS	5- 1 to 5- 6
----------------------	---------------------

5.1	Parameters for converter unit	5- 1
5.1.1	Parameter list	5- 1
5.1.2	Detailed list of parameters	5- 2
5.2	Parameters for drive unit	5- 4
5.2.1	MR-J4-DU_A_(-RJ).....	5- 4
5.2.2	MR-J4-DU_B_(-RJ).....	5- 5

6. TROUBLESHOOTING	6- 1 to 6-12
---------------------------	---------------------

6.1	Troubleshooting for MR-CR55K(4) converter unit.....	6- 1
6.1.1	Explanation for the lists	6- 1
6.1.2	Alarm/warning list.....	6- 1
6.2	Troubleshooting for drive unit	6- 2
6.2.1	Explanation for the lists	6- 2
6.2.2	Alarm list.....	6- 3
6.2.3	Warning list.....	6-10

7. DIMENSIONS	7- 1 to 7- 6
----------------------	---------------------

7.1	Converter unit (MR-CR55K_)	7- 1
7.2	Drive unit.....	7- 2
7.2.1	MR-J4-DU_A_(-RJ).....	7- 2
7.2.2	MR-J4-DU_B_(-RJ).....	7- 4

8. CHARACTERISTICS	8- 1 to 8- 8
---------------------------	---------------------

8.1	Overload protection characteristics	8- 1
8.1.1	Converter unit.....	8- 1
8.1.2	Drive unit	8- 2
8.2	Power supply capacity and generated loss	8- 3
8.3	Dynamic brake characteristics.....	8- 5
8.3.1	Dynamic brake operation	8- 5
8.3.2	Permissible load to motor inertia when the dynamic brake is used.....	8- 7
8.4	Inrush currents at power-on of main circuit/control circuit.....	8- 8

9. OPTIONS AND PERIPHERAL EQUIPMENT	9- 1 to 9-46
-------------------------------------	--------------

9.1 Cable/connector sets	9- 2
9.1.1 Combinations of cable/connector sets	9- 2
9.1.2 MR-J3CDL05M (0.5 m) protection coordination cable	9- 3
9.2 Regenerative option.....	9- 5
9.2.1 Combination and regenerative power	9- 5
9.2.2 Selection of regenerative option	9- 6
9.2.3 Parameter setting.....	9- 7
9.2.4 Connection of regenerative option	9- 8
9.2.5 Dimensions.....	9-10
9.3 External dynamic brake	9-11
9.3.1 Selection of external dynamic brake	9-11
9.3.2 Connection example	9-12
9.3.3 Timing chart.....	9-13
9.3.4 Dimensions.....	9-14
9.4 Selection example of wires	9-15
9.5 Molded-case circuit breakers, fuses, magnetic contactors	9-17
9.6 Power factor improving DC reactor	9-19
9.7 Noise reduction techniques	9-20
9.8 Earth-leakage current breaker	9-24
9.9 EMC filter (recommended).....	9-26
9.9.1 Combinations of converter unit/drive unit.....	9-26
9.9.2 Connection example	9-26
9.9.3 Dimensions.....	9-27
9.10 FR-BU2-(H) brake unit.....	9-28
9.10.1 Selection.....	9-28
9.10.2 Brake unit parameter setting	9-29
9.10.3 Connection example	9-29
9.10.4 Dimensions	9-45

10. COMPLIANCE WITH SEMI-F47 STANDARD	10- 1 to 10- 2
---------------------------------------	----------------

APPENDIX	App. - 1 to App. -12
----------	----------------------

App. 1 Peripheral equipment manufacturer (for reference).....	App.- 1
App. 2 Compliance with global standards	App.- 1

1. FUNCTIONS AND CONFIGURATION

1. FUNCTIONS AND CONFIGURATION

The following items are the same as those of MR-J4-_-(-RJ). For details of the items, refer to each chapter/section indicated in the detailed explanation field. "MR-J4-_A_" means "MR-J4-_A_(-RJ) Servo Amplifier Instruction Manual". "MR-J4-_B_" means "MR-J4-_B_(-RJ) Servo Amplifier Instruction Manual".

Model	Item	Detailed explanation
MR-J4-DU_A_(-RJ)	Summary	MR-J4-_A_ section 1.1
	Function list	MR-J4-_A_ section 1.5
MR-J4-DU_B_(-RJ)	Summary	MR-J4-_B_ section 1.1
	Function list	MR-J4-_B_ section 1.5

In MELSERVO-J4 series, drive units with the CN2L connector are also available as MR-J4-DU_A_-RJ and MR-J4-DU_B_-RJ.

By using the CN2L connector, an A/B/Z-phase differential output type external encoder can be connected to the drive unit. In a fully closed loop system, a four-wire type external encoder is connectable as well. The following table indicates the communication method and the connector of external encoders compatible with drive units.

Table 1.1 Connectors to connect from external encoders

Operation mode	External encoder communication method	Connector			
		MR-J4-DU_A_	MR-J4-DU_A_-RJ	MR-J4-DU_B_	MR-J4-DU_B_-RJ
Fully closed loop system	Two-wire type	CN2 (Note 1, 2)	CN2L	CN2 (Note 1, 2)	CN2L
	Four-wire type	/		/	
	A/B/Z-phase differential output method				
Scale measurement function	Two-wire type	/	/	CN2 (Note 1, 2)	CN2L
	Four-wire type			/	
	A/B/Z-phase differential output method				

Note 1. The MR-J4FCCBL03M branch cable is necessary.

2. When the communication method of the servo motor encoder is four-wire type, MR-J4-DU_A_ and MR-J4-DU_B_ cannot be used. Use an MR-J4-DU_A_-RJ or MR-J4-DU_B_-RJ.

1. FUNCTIONS AND CONFIGURATION

1.1 Function block diagram

1.1.1 MR-J4-DU_A_(-RJ)

The function block diagram of this servo is shown below.

POINT
<p>● The diagram shows the combination of the MR-J4-DU_A_-RJ drive unit and converter unit as an example. The MR-J4-DU_A_ drive unit does not have the CN2L connector.</p>

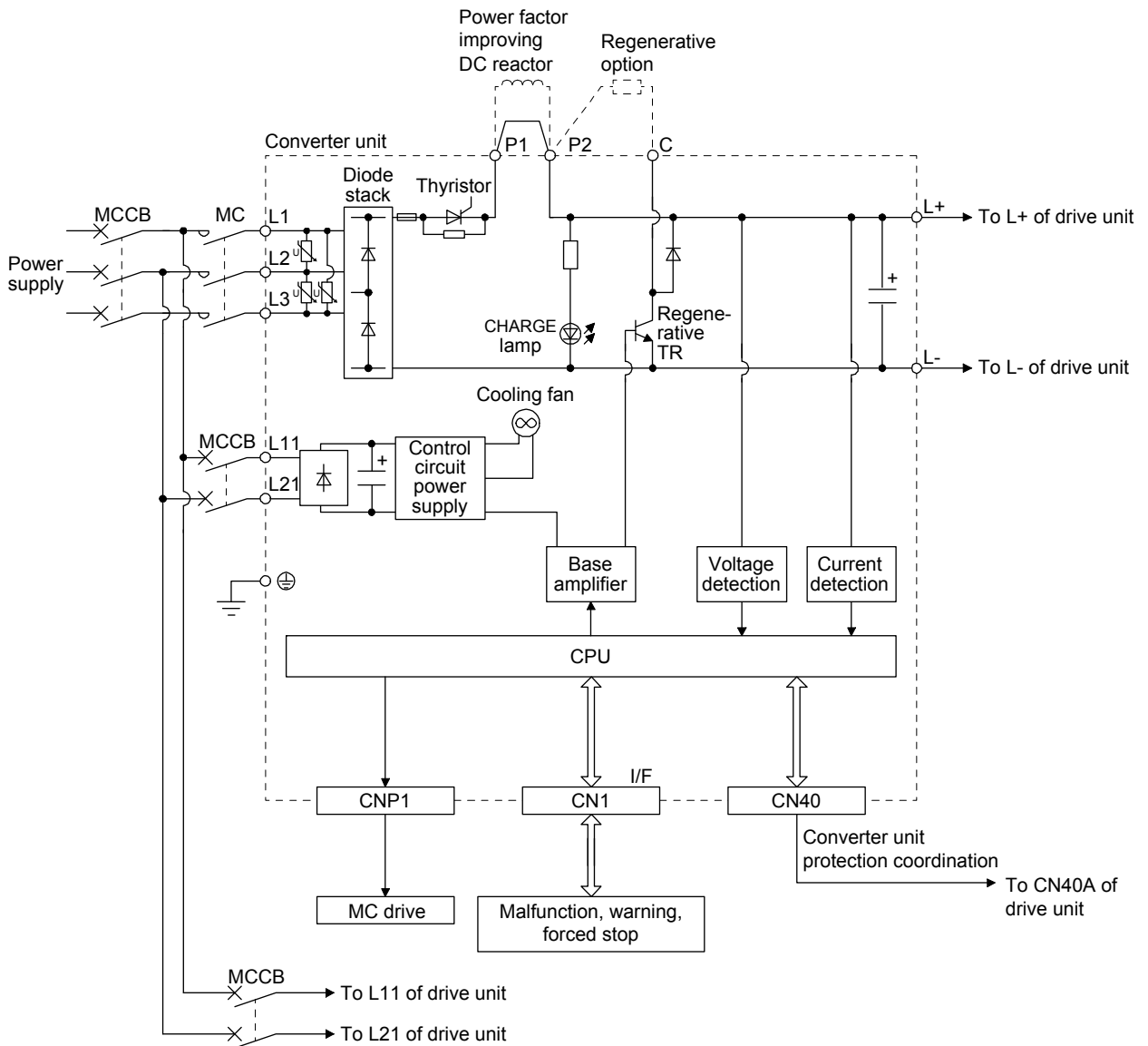

1. FUNCTIONS AND CONFIGURATION

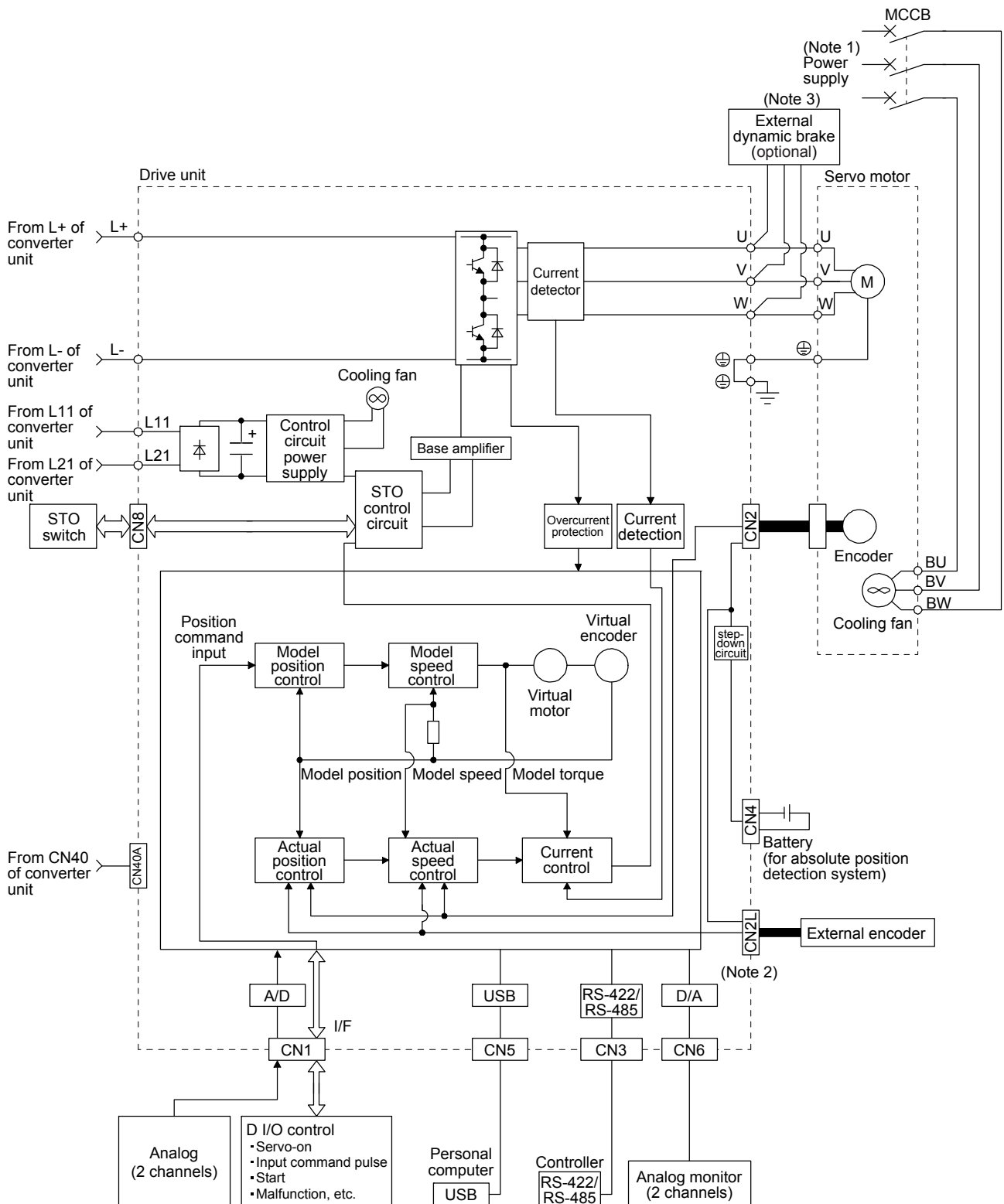

- Note 1. For specifications of the cooling fan power supply, refer to "Servo Motor Instruction Manual (Vol. 3)".
- Note 2. This is for the MR-J4-DU_A_-RJ drive unit. The MR-J4-DU_A_ drive unit does not have the CN2L connector.
- Note 3. Use an external dynamic brake for the drive unit. Failure to do so will cause an accident because the servo motor does not stop immediately but coasts at an alarm occurrence for which the servo motor does not decelerate to stop. Ensure the safety in the entire equipment. For wiring of the external dynamic brake, refer to section 9.3. For alarms for which the servo motor does not decelerate to stop, refer to chapter 6.

1. FUNCTIONS AND CONFIGURATION

1.1.2 MR-J4-DU_B_(-RJ)

The function block diagram of this servo is shown below.

POINT

- The diagram shows the combination of the MR-J4-DU_B_-RJ drive unit and converter unit as an example. The MR-J4-DU_B_ drive unit does not have the CN2L connector.

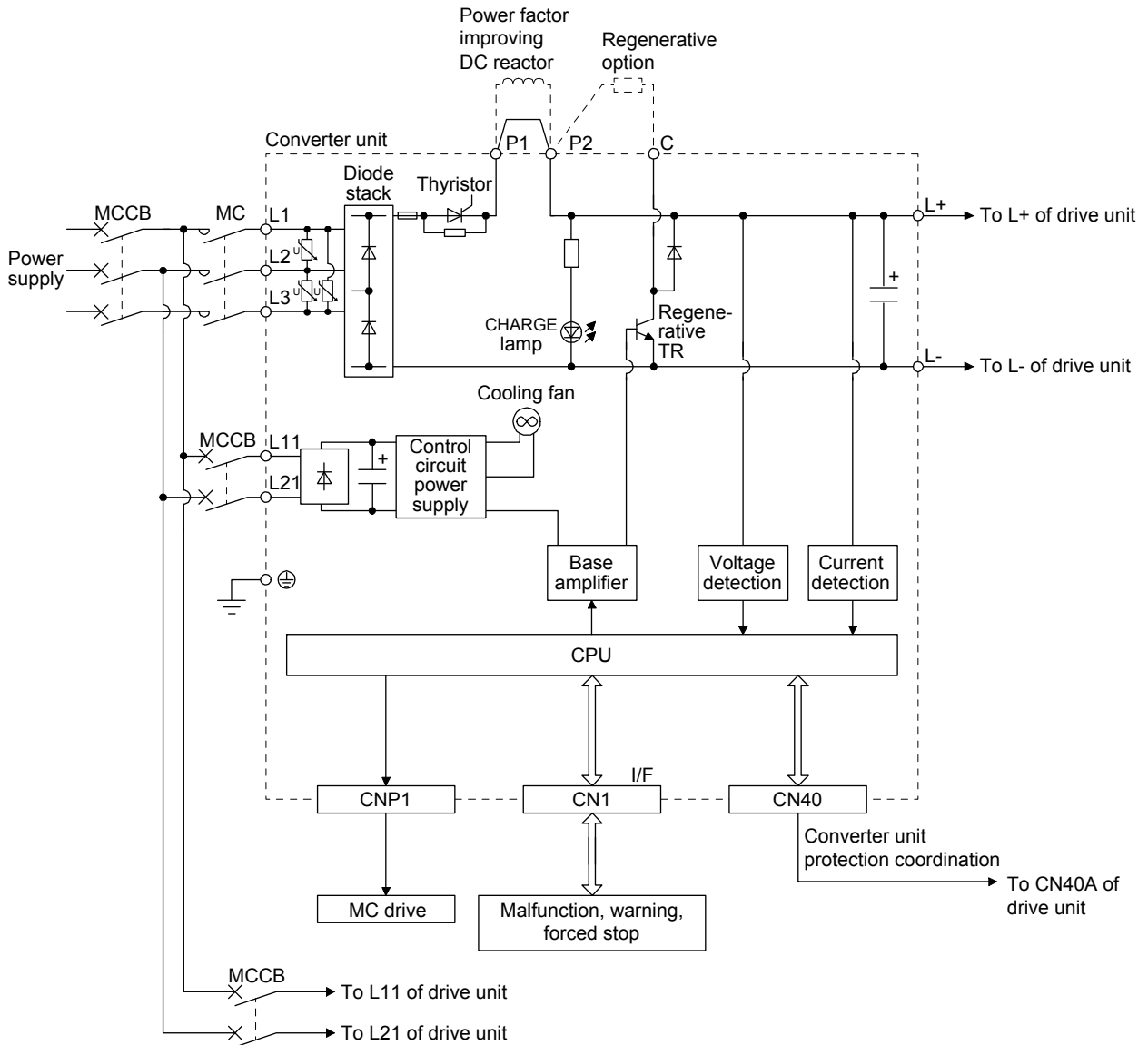

1. FUNCTIONS AND CONFIGURATION

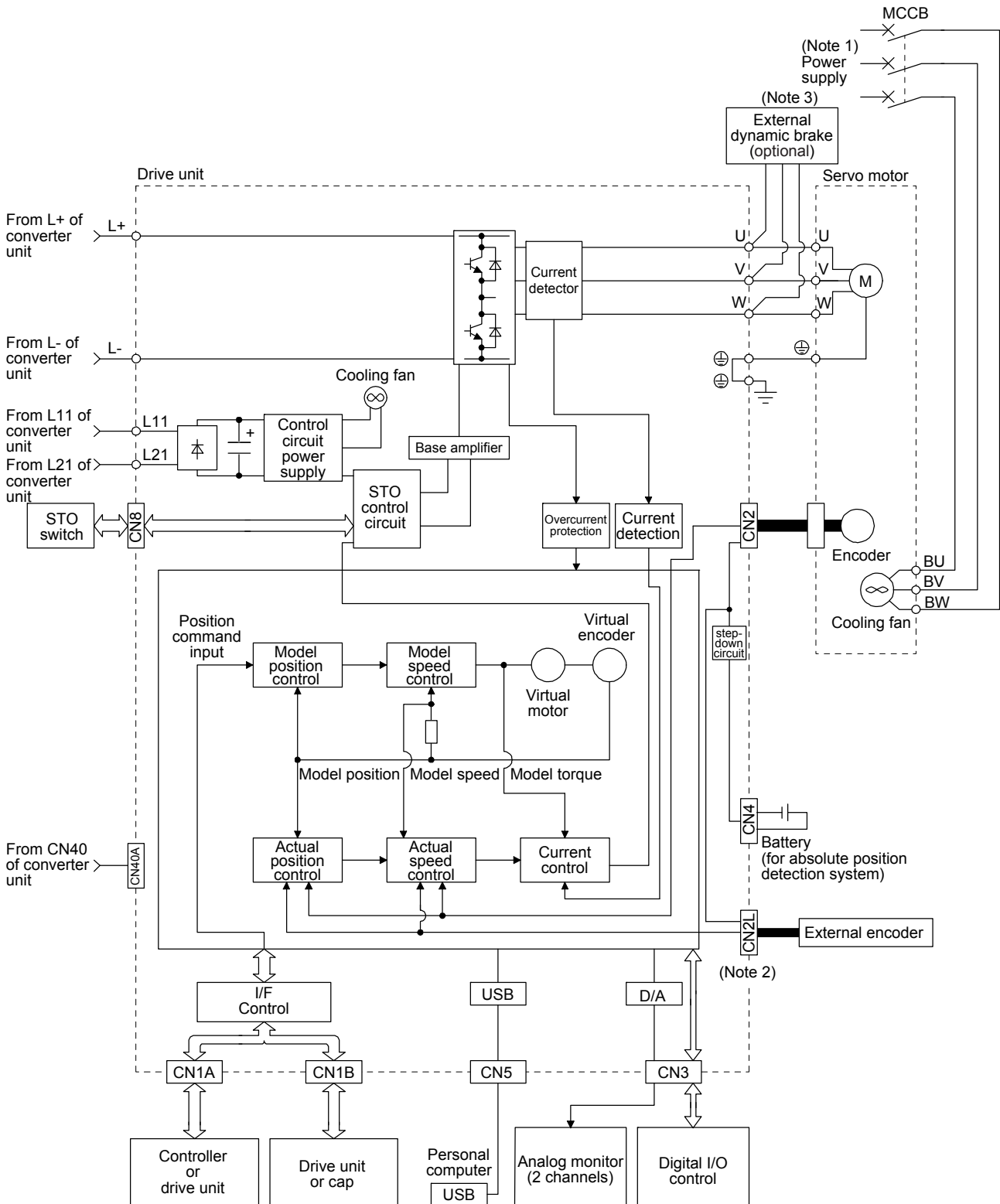

- Note 1. For specifications of the cooling fan power supply, refer to "Servo Motor Instruction Manual (Vol. 3)".
- Note 2. This is for the MR-J4-DU_B_-RJ drive unit. The MR-J4-DU_B_ drive unit does not have the CN2L connector.
- Note 3. Use an external dynamic brake for the drive unit. Failure to do so will cause an accident because the servo motor does not stop immediately but coasts at an alarm occurrence for which the servo motor does not decelerate to stop. Ensure the safety in the entire equipment. For wiring of the external dynamic brake, refer to section 9.3. For alarms for which the servo motor does not decelerate to stop, refer to chapter 6.

1. FUNCTIONS AND CONFIGURATION

1.2 Standard specifications

1.2.1 Converter unit

Model: MR-CR_		55K	55K4	
Output	Rated voltage	270 V DC to 324 V DC		
	Rated current [A]	215.9	113.8	
Main circuit power supply input	Voltage/Frequency	3-phase 200 V AC to 240 V AC, 50 Hz/60 Hz	3-phase 380 V AC to 480 V AC, 50 Hz/60 Hz	
	Rated current [A]	191.3	100.7	
	Permissible voltage fluctuation	3-phase 170 V AC to 264 V AC	3-phase 323 V AC to 528 V AC	
	Permissible frequency fluctuation	Within ±5%		
	Power supply capacity [kVA]	Refer to section 8.2.		
	Inrush current [A]	Refer to section 8.4.		
Control circuit power supply	Voltage/Frequency	1-phase 200 V AC to 240 V AC, 50 Hz/60 Hz	1-phase 380 V AC to 480 V AC, 50 Hz/60 Hz	
	Rated current [A]	0.3	0.2	
	Permissible voltage fluctuation	1-phase 170 V AC to 264 V AC	1-phase 323 V AC to 528 V AC	
	Permissible frequency fluctuation	Within ±5%		
	Power consumption [W]	45		
	Inrush current [A]	Refer to section 8.4.		
Interface power supply	Voltage	24 V DC ± 10%		
	Current capacity [A]	(Note 1) 0.15		
Rated output [kW]		55		
Regenerative power (regenerative option)		One MR-RB139: 1300 W Three MR-RB137: 3900 W	One MR-RB137-4: 1300 W Three MR-RB13V-4: 3900 W	
Protective functions		Regenerative overvoltage shut-off, overload shut-off (electronic thermal), regenerative error protection, undervoltage protection, and instantaneous power failure protection		
Compliance to global standards	CE marking	LVD: EN 61800-5-1 EMC: EN 61800-3		
	UL standard	UL 508C		
Structure (IP rating)		Force cooling, open (IP20) (Note 2)		
Environment	Ambient temperature	Operation	0 °C to 55 °C (non-freezing)	
		Storage	-20 °C to 65 °C (non-freezing)	
	Ambient humidity	Operation	90 %RH or less (non-condensing)	
		Storage		
	Ambience		Indoors (no direct sunlight), free from corrosive gas, flammable gas, oil mist, dust, and dirt	
	Altitude		2000 m or less above sea level (Note 3)	
Vibration resistance		5.9 m/s ² or less, at 10 Hz to 55 Hz (directions of X, Y and Z axes)		
Mass [kg]		22		

- Note 1. When all I/O signals are used, the applicable value is 0.15 A. The current capacity can be decreased by reducing the number of I/O points.
2. Except for the terminal block.
3. Follow the restrictions in section 2.5 when using the servo amplifiers at altitude exceeding 1000 m and up to 2000 m over sea level.

1. FUNCTIONS AND CONFIGURATION

1.2.2 Drive unit

(1) MR-J4-DU_A_(-RJ)

(a) 200 V class

Model: MR-J4-DU_(-RJ)		30KA	37KA
Output	Rated voltage	3-phase 170 V AC	
	Rated current [A]	174	204
Main circuit power supply input		The main circuit power of the drive unit is supplied by the converter unit.	
Control circuit power supply	Voltage/Frequency	1-phase 200 V AC to 240 V AC, 50 Hz/60 Hz	
	Rated current [A]	0.3	
	Permissible voltage fluctuation	1-phase 170 V AC to 264 V AC	
	Permissible frequency fluctuation	Within $\pm 5\%$	
	Power consumption [W]	45	
	Inrush current [A]	Refer to section 8.4.	
Interface power supply	Voltage	24 V DC $\pm 10\%$	
	Current capacity [A]	(Note 1) 0.5 (including CN8 connector signals)	
Control method		Sine-wave PWM control, current control method	
Dynamic brake		External option (Note 5, 7)	
Fully closed loop control		Compatible	
Load-side encoder interface (Note 6)		Mitsubishi high-speed serial communication	
Communication function		USB: connection to a personal computer or others (MR Configurator2-compatible)	
		RS-422/RS-485: 1 : n communication (up to 32 axes) (Note 9)	
Encoder output pulses		Compatible (A/B/Z-phase pulse)	
Analog monitor		Two channels	
Position control mode	Max. input pulse frequency	4 Mpulses/s (for differential receiver) (Note 4), 200 kpulses/s (for open collector)	
	Positioning feedback pulse	Encoder resolution (resolution per servo motor revolution): 22 bits	
	Command pulse multiplying factor	Electronic gear A:1 to 16777215, B:1 to 16777215, 1/10 < A/B < 4000	
	In-position range setting	0 pulse to ± 65535 pulses (command pulse unit)	
	Error excessive	± 3 revolutions	
	Torque limit	Set by parameter setting or external analog input (0 V DC to +10 V DC/maximum torque)	
Speed control mode	Speed control range	Analog speed command 1: 2000, internal speed command 1: 5000	
	Analog speed command input	0 V DC to ± 10 V DC/rated speed (The speed at 10 V is changeable with [Pr. PC12].)	
	Speed fluctuation ratio	$\pm 0.01\%$ or less (load fluctuation: 0% to 100%), 0% (power fluctuation: $\pm 10\%$) $\pm 0.2\%$ or less (ambient temperature: 25 °C ± 10 °C) when using analog speed command	
	Torque limit	Set by parameter setting or external analog input (0 V DC to +10 V DC/maximum torque)	
Torque control mode	Analog torque command input	0 V DC to ± 8 V DC/maximum torque (input impedance 10 k Ω to 12 k Ω)	
	Speed limit	Set by parameter setting or external analog input (0 V DC to 10 V DC/rated speed)	
Protective functions		Overcurrent shut-off, overload shut-off (electronic thermal), servo motor overheat protection, encoder error protection, undervoltage protection, Instantaneous power failure protection, overspeed protection, and error excessive protection	
Functional safety		STO (IEC/EN 61800-5-2)	
Safety performance	Standards certified by CB (Note 10)	EN ISO 13849-1 category 3 PL e, IEC 61508 SIL 3, EN 62061 SIL CL3, EN 61800-5-2 SIL 3	
	Response performance (Note 2)	8 ms or less (STO input off \rightarrow energy shut off)	
	Test pulse input (STO)	Test pulse interval: 1 Hz to 25 Hz Test pulse off time: Up to 1 ms	
	Mean time to dangerous failure (MTTFd)	100 years or longer	
	Diagnosis coverage (DC)	Medium (90% to 99%)	
	Average probability of dangerous failures per hour (PFH)	1.68×10^{-10} [1/h]	

1. FUNCTIONS AND CONFIGURATION

Model: MR-J4-DU_(-RJ)		30KA	37KA	
Compliance to global standards	CE marking	LVD: EN 61800-5-1 EMC: EN 61800-3 MD: EN ISO 13849-1, EN 61800-5-2, EN 62061		
	UL standard	UL 508C		
Structure (IP rating)		Force cooling, open (IP20) (Note 3)		
Environment	Ambient temperature	Operation	0 °C to 55 °C (non-freezing)	
		Storage	-20 °C to 65 °C (non-freezing)	
	Ambient humidity	Operation	90 %RH or less (non-condensing)	
		Storage		
	Ambience		Indoors (no direct sunlight), free from corrosive gas, flammable gas, oil mist, dust, and dirt	
	Altitude		2000 m or less above sea level (Note 8)	
Vibration resistance		5.9 m/s ² or less, at 10 Hz to 55 Hz (directions of X, Y and Z axes)		
Mass [kg]		21		

- Note
- When all I/O signals are used, the applicable value is 0.5 A. The current capacity can be decreased by reducing the number of I/O points.
 - Test pulse is a signal which instantaneously turns off a signal to the drive unit at a constant period for external circuit to self-diagnose.
 - Except for the terminal block.
 - 1 Mpulse/s or lower commands are supported in the initial setting. When inputting commands over 1 Mpulse/s and lower than 4 Mpulses/s, change the setting in [Pr. PA13].
 - Use an external dynamic brake for the drive unit. Failure to do so will cause an accident because the servo motor does not stop immediately but coasts at emergency stop. Ensure the safety in the entire equipment. For wiring of the external dynamic brake, refer to section 9.3.
 - The MR-J4-DU_A drive unit is compatible only with the two-wire type.
The MR-J4-DU_A-RJ drive unit is compatible with the two-wire type, four-wire type, and A/B/Z-phase differential output method. Refer to table 1.1 for details.
 - The external dynamic brake cannot be used for compliance with SEMI-F47 standard. Do not assign DB (Dynamic brake interlock) in [Pr. PD23] to [Pr. PD26], [Pr. PD28], or [Pr. PD47]. Failure to do so will cause the drive unit to become servo-off when an instantaneous power failure occurs.
 - Follow the restrictions in section 2.5 when using the servo amplifiers at altitude exceeding 1000 m and up to 2000 m over sea level.
 - RS-485 communication is available with drive units manufactured in January 2015 or later.
 - The safety level depends on the setting value of [Pr. PF18 STO diagnosis error detection time] and whether STO input diagnosis by TOFB output is performed or not.

1. FUNCTIONS AND CONFIGURATION

(b) 400 V class

Model: MR-J4-DU_(-RJ)		30KA4	37KA4	45KA4	55KA4
Output	Rated voltage	3-phase 323 V AC			
	Rated current [A]	87	102	131	143
Main circuit power supply input		The main circuit power of the drive unit is supplied by the converter unit.			
Control circuit power supply	Voltage/Frequency	1-phase 380 V AC to 480 V AC, 50 Hz/60 Hz			
	Rated current [A]	0.2			
	Permissible voltage fluctuation	1-phase 323 V AC to 528 V AC			
	Permissible frequency fluctuation	Within $\pm 5\%$			
	Power consumption [W]	45			
	Inrush current [A]	Refer to section 8.4.			
Interface power supply	Voltage	24 V DC $\pm 10\%$			
	Current capacity [A]	(Note 1) 0.5 (including CN8 connector signals)			
Control method		Sine-wave PWM control, current control method			
Dynamic brake		External option (Note 5, 7)			
Fully closed loop control		Compatible			
Load-side encoder interface (Note 6)		Mitsubishi high-speed serial communication			
Communication function		USB: connection to a personal computer or others (MR Configurator2-compatible)			
		RS-422/RS-485: 1 : n communication (up to 32 axes) (Note 9)			
Encoder output pulses		Compatible (A/B/Z-phase pulse)			
Analog monitor		Two channels			
Position control mode	Max. input pulse frequency	4 Mpulses/s (for differential receiver) (Note 4), 200 kpulses/s (for open collector)			
	Positioning feedback pulse	Encoder resolution (resolution per servo motor revolution): 22 bits			
	Command pulse multiplying factor	Electronic gear A:1 to 16777215, B:1 to 16777215, $1/10 < A/B < 4000$			
	In-position range setting	0 pulse to ± 65535 pulses (command pulse unit)			
	Error excessive	± 3 revolutions			
	Torque limit	Set by parameter setting or external analog input (0 V DC to +10 V DC/maximum torque)			
Speed control mode	Speed control range	Analog speed command 1: 2000, internal speed command 1: 5000			
	Analog speed command input	0 V DC to ± 10 V DC/rated speed (The speed at 10 V is changeable with [Pr. PC12].)			
	Speed fluctuation ratio	$\pm 0.01\%$ or less (load fluctuation: 0% to 100%), 0% (power fluctuation: $\pm 10\%$) $\pm 0.2\%$ or less (ambient temperature: $25\text{ }^{\circ}\text{C} \pm 10\text{ }^{\circ}\text{C}$) when using analog speed command			
	Torque limit	Set by parameter setting or external analog input (0 V DC to +10 V DC/maximum torque)			
Torque control mode	Analog torque command input	0 V DC to ± 8 V DC/maximum torque (input impedance 10 k Ω to 12 k Ω)			
	Speed limit	Set by parameter setting or external analog input (0 V DC to 10 V DC/rated speed)			
Protective functions		Overcurrent shut-off, overload shut-off (electronic thermal), servo motor overheat protection, encoder error protection, undervoltage protection, Instantaneous power failure protection, overspeed protection, and error excessive protection			
Functional safety		STO (IEC/EN 61800-5-2)			
Safety performance	Standards certified by CB (Note 10)	EN ISO 13849-1 category 3 PL e, IEC 61508 SIL 3, EN 62061 SIL CL3, EN 61800-5-2 SIL 3			
	Response performance (Note 2) Test pulse input (STO)	8 ms or less (STO input off \rightarrow energy shut off) Test pulse interval: 1 Hz to 25 Hz Test pulse off time: Up to 1 ms			
	Mean time to dangerous failure (MTTFd)	100 years or longer			
	Diagnosis coverage (DC)	Medium (90% to 99%)			
	Average probability of dangerous failures per hour (PFH)	1.68×10^{-10} [1/h]			

1. FUNCTIONS AND CONFIGURATION

Model: MR-J4-DU_(-RJ)		30KA4	37KA4	45KA4	55KA4
Compliance to global standards	CE marking	LVD: EN 61800-5-1 EMC: EN 61800-3 MD: EN ISO 13849-1, EN 61800-5-2, EN 62061			
	UL standard	UL 508C			
Structure (IP rating)		Force cooling, open (IP20) (Note 3)			
Environment	Ambient temperature	Operation	0 °C to 55 °C (non-freezing)		
		Storage	-20 °C to 65 °C (non-freezing)		
	Ambient humidity	Operation	90 %RH or less (non-condensing)		
		Storage			
	Ambience		Indoors (no direct sunlight), free from corrosive gas, flammable gas, oil mist, dust, and dirt		
	Altitude		2000 m or less above sea level (Note 8)		
Vibration resistance		5.9 m/s ² or less, at 10 Hz to 55 Hz (directions of X, Y and Z axes)			
Mass [kg]		16		21	

- Note
- When all I/O signals are used, the applicable value is 0.5 A. The current capacity can be decreased by reducing the number of I/O points.
 - Test pulse is a signal which instantaneously turns off a signal to the drive unit at a constant period for external circuit to self-diagnose.
 - Except for the terminal block.
 - 1 Mpulse/s or lower commands are supported in the initial setting. When inputting commands over 1 Mpulse/s and lower than 4 Mpulses/s, change the setting in [Pr. PA13].
 - Use an external dynamic brake for the drive unit. Failure to do so will cause an accident because the servo motor does not stop immediately but coasts at emergency stop. Ensure the safety in the entire equipment. For wiring of the external dynamic brake, refer to section 9.3.
 - The MR-J4-DU_A4 drive unit is compatible only with the two-wire type.
The MR-J4-DU_A4-RJ drive unit is compatible with the two-wire type, four-wire type, and A/B/Z-phase differential output method. Refer to table 1.1 for details.
 - The external dynamic brake cannot be used for compliance with SEMI-F47 standard. Do not assign DB (Dynamic brake interlock) in [Pr. PD23] to [Pr. PD26], [Pr. PD28], or [Pr. PD47]. Failure to do so will cause the drive unit to become servo-off when an instantaneous power failure occurs.
 - Follow the restrictions in section 2.5 when using the servo amplifiers at altitude exceeding 1000 m and up to 2000 m over sea level.
 - RS-485 communication is available with drive units manufactured in January 2015 or later.
 - The safety level depends on the setting value of [Pr. PF18 STO diagnosis error detection time] and whether STO input diagnosis by TOFB output is performed or not.

1. FUNCTIONS AND CONFIGURATION

(2) MR-J4-DU_B_(-RJ) (a) 200 V class

Model: MR-J4-DU_(-RJ)		30KB	37KB
Output	Rated voltage	3-phase 170 V AC	
	Rated current [A]	174	204
Main circuit power supply input		The main circuit power of the drive unit is supplied by the converter unit.	
Control circuit power supply	Voltage/Frequency	1-phase 200 V AC to 240 V AC, 50 Hz/60 Hz	
	Rated current [A]	0.3	
	Permissible voltage fluctuation	1-phase 170 V AC to 264 V AC	
	Permissible frequency fluctuation	Within $\pm 5\%$	
	Power consumption [W]	45	
Interface power supply	Inrush current [A]	Refer to section 8.4.	
	Voltage	24 V DC $\pm 10\%$	
	Current capacity [A]	(Note 1) 0.3 (including CN8 connector signals)	
Control method		Sine-wave PWM control, current control method	
Dynamic brake		External option (Note 6, 7)	
SSCNET III/H communication cycle (Note 5)		0.222 ms, 0.444 ms, 0.888 ms	
Fully closed loop control		Compatible	
Load-side encoder interface (Note 4)		Mitsubishi high-speed serial communication	
Communication function		USB: connection to a personal computer or others (MR Configurator2-compatible)	
Encoder output pulses		Compatible (A/B/Z-phase pulse)	
Analog monitor		Two channels	
Protective functions		Overcurrent shut-off, overload shut-off (electronic thermal), servo motor overheat protection, encoder error protection, undervoltage protection, instantaneous power failure protection, overspeed protection, and error excessive protection	
Functional safety		STO (IEC/EN 61800-5-2)	
Safety performance	Standards certified by CB (Note 9)	EN ISO 13849-1 category 3 PL e, IEC 61508 SIL 3, EN 62061 SIL CL3, EN 61800-5-2 SIL 3	
	Response performance	8 ms or less (STO input off \rightarrow energy shut off)	
	(Note 2) Test pulse input (STO)	Test pulse interval: 1 Hz to 25 Hz Test pulse off time: Up to 1 ms	
	Mean time to dangerous failure (MTTFd)	100 years or longer	
	Diagnosis coverage (DC)	Medium (90% to 99%)	
	Average probability of dangerous failures per hour (PFH)	1.68×10^{-10} [1/h]	
Compliance to global standards	CE marking	LVD: EN 61800-5-1 EMC: EN 61800-3 MD: EN ISO 13849-1, EN 61800-5-2, EN 62061	
	UL standard	UL 508C	
Structure (IP rating)		Force cooling, open (IP20) (Note 3)	
Environment	Ambient temperature	Operation	0 °C to 55 °C (non-freezing)
		Storage	-20 °C to 65 °C (non-freezing)
	Ambient humidity	Operation	90 %RH or less (non-condensing)
		Storage	
	Ambience	Indoors (no direct sunlight), free from corrosive gas, flammable gas, oil mist, dust, and dirt	
Altitude	2000 m or less above sea level (Note 8)		
Vibration resistance		5.9 m/s ² or less, at 10 Hz to 55 Hz (directions of X, Y and Z axes)	
Mass [kg]		21	

1. FUNCTIONS AND CONFIGURATION

- Note
1. When all I/O signals are used, the applicable value is 0.3 A. The current capacity can be decreased by reducing the number of I/O points.
 2. Test pulse is a signal which instantaneously turns off a signal to the drive unit at a constant period for external circuit to self-diagnose.
 3. Except for the terminal block.
 4. The MR-J4-DU_B drive unit is compatible only with the two-wire type. The MR-J4-DU_B-RJ drive unit is compatible with the two-wire type, four-wire type, and A/B/Z-phase differential output method. Refer to table 1.1 for details.
 5. The communication cycle depends on the controller specifications and the number of axes connected.
 6. Use an external dynamic brake for the drive unit. Failure to do so will cause an accident because the servo motor does not stop immediately but coasts at emergency stop. Ensure the safety in the entire equipment. For wiring of the external dynamic brake, refer to section 9.3.
 7. The external dynamic brake cannot be used for compliance with SEMI-F47 standard. Do not assign DB (Dynamic brake interlock) in [Pr. PD07] to [Pr. PD09]. Failure to do so will cause the drive unit to become servo-off when an instantaneous power failure occurs.
 8. Follow the restrictions in section 2.5 when using the servo amplifiers at altitude exceeding 1000 m and up to 2000 m over sea level.
 9. The safety level depends on the setting value of [Pr. PF18 STO diagnosis error detection time] and whether STO input diagnosis by TOFB output is performed or not.

1. FUNCTIONS AND CONFIGURATION

(b) 400 V class

Model: MR-J4-DU_(-RJ)		30KB4	37KB4	45KB4	55KB4
Output	Rated voltage	3-phase 323 V AC			
	Rated current [A]	87	102	131	143
Main circuit power supply input		The main circuit power of the drive unit is supplied by the converter unit.			
Control circuit power supply	Voltage/Frequency	1-phase 380 V AC to 480 V AC, 50 Hz/60 Hz			
	Rated current [A]	0.2			
	Permissible voltage fluctuation	1-phase 323 V AC to 528 V AC			
	Permissible frequency fluctuation	Within $\pm 5\%$			
	Power consumption [W]	45			
	Inrush current [A]	Refer to section 8.4.			
Interface power supply	Voltage	24 V DC $\pm 10\%$			
	Current capacity [A]	(Note 1) 0.3 (including CN8 connector signals)			
Control method		Sine-wave PWM control, current control method			
Dynamic brake		External option (Note 6, 7)			
SSCNET III/H communication cycle (Note 5)		0.222 ms, 0.444 ms, 0.888 ms			
Fully closed loop control		Compatible			
Load-side encoder interface (Note 4)		Mitsubishi high-speed serial communication			
Communication function		USB: connection to a personal computer or others (MR Configurator2-compatible)			
Encoder output pulses		Compatible (A/B/Z-phase pulse)			
Analog monitor		Two channels			
Protective functions		Overcurrent shut-off, overload shut-off (electronic thermal), servo motor overheat protection, encoder error protection, undervoltage protection, Instantaneous power failure protection, overspeed protection, and error excessive protection			
Functional safety		STO (IEC/EN 61800-5-2)			
Safety performance	Standards certified by CB (Note 9)	EN ISO 13849-1 category 3 PL e, IEC 61508 SIL 3, EN 62061 SIL CL3, EN 61800-5-2 SIL 3			
	Response performance	8 ms or less (STO input off \rightarrow energy shut off)			
	(Note 2) Test pulse input (STO)	Test pulse interval: 1 Hz to 25 Hz Test pulse off time: Up to 1 ms			
	Mean time to dangerous failure (MTTFd)	100 years or longer			
	Diagnosis coverage (DC)	Medium (90% to 99%)			
	Average probability of dangerous failures per hour (PFH)	1.68×10^{-10} [1/h]			
Compliance to global standards	CE marking	LVD: EN 61800-5-1 EMC: EN 61800-3 MD: EN ISO 13849-1, EN 61800-5-2, EN 62061			
	UL standard	UL 508C			
Structure (IP rating)		Force cooling, open (IP20) (Note 3)			
Environment	Ambient temperature	Operation	0 °C to 55 °C (non-freezing)		
		Storage	-20 °C to 65 °C (non-freezing)		
	Ambient humidity	Operation	90 %RH or less (non-condensing)		
		Storage			
	Ambience	Indoors (no direct sunlight), free from corrosive gas, flammable gas, oil mist, dust, and dirt			
	Altitude	2000 m or less above sea level (Note 8)			
Vibration resistance	5.9 m/s ² or less, at 10 Hz to 55 Hz (directions of X, Y and Z axes)				
Mass [kg]		16		21	

1. FUNCTIONS AND CONFIGURATION

- Note
1. When all I/O signals are used, the applicable value is 0.3 A. The current capacity can be decreased by reducing the number of I/O points.
 2. Test pulse is a signal which instantaneously turns off a signal to the drive unit at a constant period for external circuit to self-diagnose.
 3. Except for the terminal block.
 4. The MR-J4-DU_B4 drive unit is compatible only with the two-wire type. The MR-J4-DU_B4-RJ drive unit is compatible with the two-wire type, four-wire type, and A/B/Z-phase differential output method. Refer to table 1.1 for details.
 5. The communication cycle depends on the controller specifications and the number of axes connected.
 6. Use an external dynamic brake for the drive unit. Failure to do so will cause an accident because the servo motor does not stop immediately but coasts at emergency stop. Ensure the safety in the entire equipment. For wiring of the external dynamic brake, refer to section 9.3.
 7. The external dynamic brake cannot be used for compliance with SEMI-F47 standard. Do not assign DB (Dynamic brake interlock) in [Pr. PD07] to [Pr. PD09]. Failure to do so will cause the drive unit to become servo-off when an instantaneous power failure occurs.
 8. Follow the restrictions in section 2.5 when using the servo amplifiers at altitude exceeding 1000 m and up to 2000 m over sea level.
 9. The safety level depends on the setting value of [Pr. PF18 STO diagnosis error detection time] and whether STO input diagnosis by TOFB output is performed or not.

1. FUNCTIONS AND CONFIGURATION

1.3 Combinations of converter units, drive units and servo motors

(1) 200 V class

Converter unit	Drive unit	Servo motor	
		HG-JR_	
		1000 r/min series	1500 r/min series
MR-CR55K	MR-J4-DU30K_(-RJ)	30K1	30K1M
	MR-J4-DU37K_(-RJ)	37K1	37K1M

(2) 400 V class

Converter unit	Drive unit	Servo motor	
		HG-JR_	
		1000 r/min series	1500 r/min series
MR-CR55K4	MR-J4-DU30K_4(-RJ)	30K14	30K1M4
	MR-J4-DU37K_4(-RJ)	37K14	37K1M4
	MR-J4-DU45K_4(-RJ)		45K1M4
	MR-J4-DU55K_4(-RJ)		55K1M4

1.4 Model designation

(1) Rating plate

The following shows an example of rating plate for explanation of each item.

(a) Converter unit

 AC SERVO SER. A33001001 MODEL MR-CR55K POWER : 55kW INPUT : 3AC200-240V 191.3A 50Hz/60Hz OUTPUT : DC270-324V 215.9A STD.: IEC/EN61800-5-1 MAN.: IB0300228 Max. Surrounding Air Temp.: 55°C IP20 (Terminal block IP00) MSIP-REI-MEK- TC300A911G51 MITSUBISHI ELECTRIC CORPORATION DATE: 2014-6 TOKYO 100-8310, JAPAN MADE IN JAPAN (PASSED)	Serial number
	Model
	Capacity
	Applicable power supply
	Rated output current
	Standard, Manual number
	Ambient temperature
	IP rating
	KC certification number
	The year and month of manufacture
	Country of origin

(b) Drive unit

 AC SERVO SER. A33001001 MODEL MR-J4-DU30KB POWER : 30kW INPUT : DC270-324V 117.7A OUTPUT : 3PH170V 0-360Hz 174.0A STD.: IEC/EN61800-5-1 MAN.: IB0300228 Max. Surrounding Air Temp.: 55°C IP20 (Terminal block IP00) MSIP-REI-MEK- TC300A916G51 MITSUBISHI ELECTRIC CORPORATION DATE: 2014-6 TOKYO 100-8310, JAPAN MADE IN JAPAN (PASSED)	Serial number
	Model
	Capacity
	Applicable power supply
	Rated output current
	Standard, Manual number
	Ambient temperature
	IP rating
	KC certification number
	The year and month of manufacture
	Country of origin

1. FUNCTIONS AND CONFIGURATION

(2) Model

The following describes what each block of a model name indicates. Not all combinations of the symbols are available.

(a) Converter unit

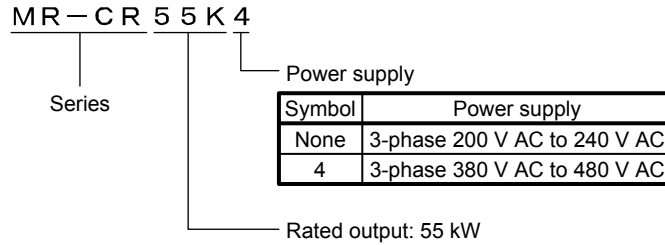

(b) Drive unit

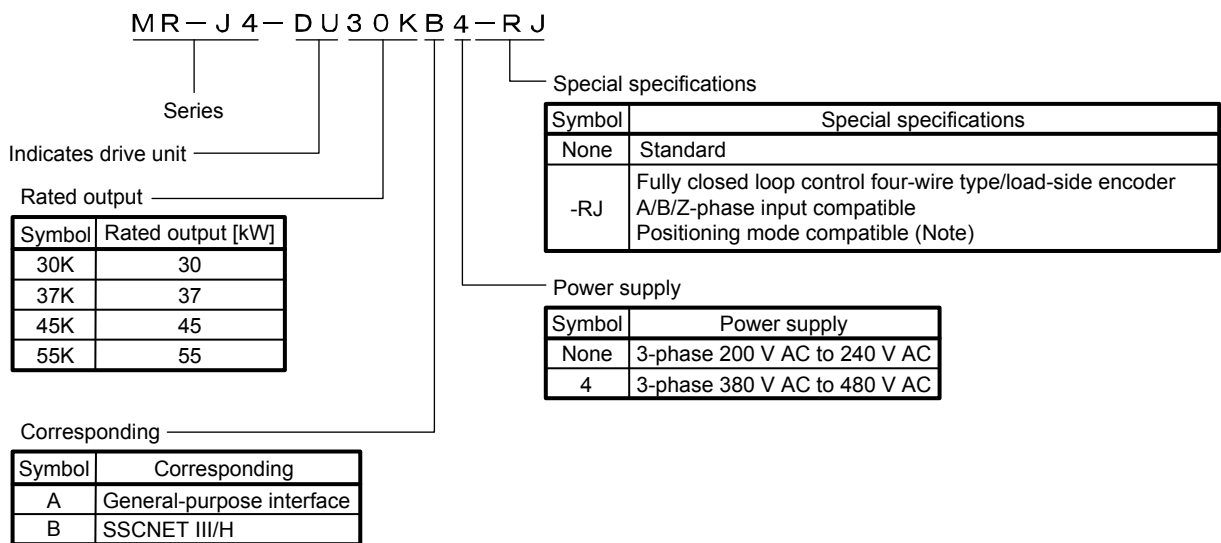

Note. The positioning mode is available with MR-J4-DU_A_-RJ drive units only.

1. FUNCTIONS AND CONFIGURATION

1.5 Structure

1.5.1 Parts identification

(1) Converter unit (MR-CR55K(4))

POINT

● The converter unit is shown with the terminal cover open. For opening or closing of the terminal cover, refer to section 1.5.2.

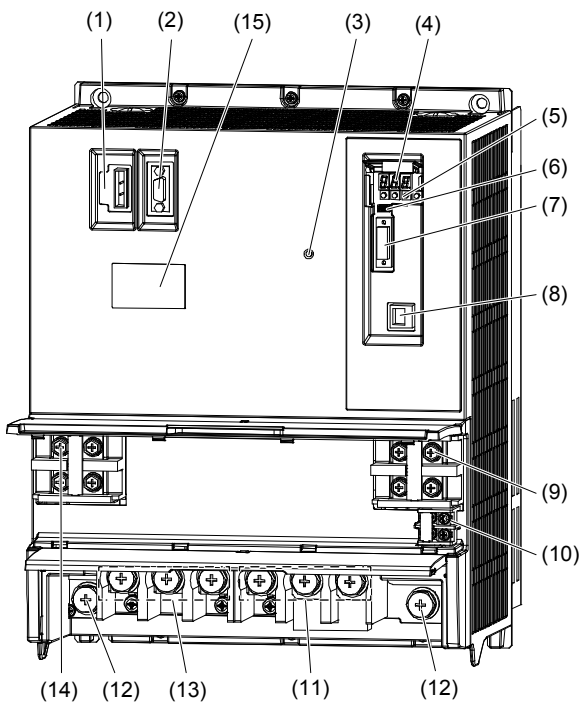

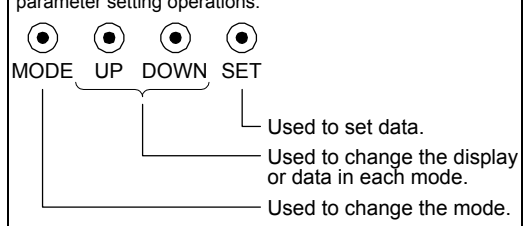
No.	Name/Application	Detailed explanation
(1)	Magnetic contactor control connector (CNP1) Used to connect the coil of the magnetic contactor.	Section 3.3.1
(2)	I/O signal connector (CN1) Used to connect digital I/O signals.	
(3)	Charge lamp Lights up when the main circuit is charged. While this lamp is lit, do not reconnect the cables.	
(4)	Display The 3-digit, 7-segment LED display shows the converter unit status and the alarm number.	
(5)	Operation section Used to perform status display, diagnostic, alarm, and parameter setting operations. 	Section 4.3
(6)	Manufacturer setting connector (CN6) This is for manufacturer setting. Although the shape is similar to the analog monitor connector (CN6) of the drive unit, do not connect anything including an analog monitor.	
(7)	Protection coordination connector (CN40) Used to connect CN40A of the drive unit.	
(8)	Manufacturer setting connector (CN3) This is for manufacturer setting. Although the shape is similar to the RS-422/RS-485 communication connector (CN3) of the drive unit, do not connect anything, including a personal computer and parameter unit.	
(9)	L+/L- terminal (TE2-2) Used to connect a drive unit using a bus bar supplied with the drive unit.	
(10)	Control circuit terminal L11 and L21 (TE3) Used to connect the control circuit power supply.	Section 3.1 Section 3.2
(11)	Regenerative option/Power factor improving DC reactor (TE1-2) Used to connect a regenerative option or a power factor improving DC reactor.	
(12)	Protective earth (PE) terminal Grounding terminal	
(13)	Main circuit terminal block (TE1-1) Used to connect the input power supply.	
(14)	L+/L- terminal (TE2-1) When using a brake unit, connect it to this terminal. Do not connect anything other than the brake unit.	
(15)	Rating plate	Section 1.4

1. FUNCTIONS AND CONFIGURATION

(2) Drive unit

POINT	
●	The drive unit is shown with the terminal cover open. For opening or closing of the terminal cover, refer to section 1.5.2.

(a) MR-J4-DU_A_(-RJ)

"MR-J4-_A_" means "MR-J4-_A_(-RJ) Servo Amplifier Instruction Manual".

1. FUNCTIONS AND CONFIGURATION

1) 200 V class

a) MR-J4-DU30KA(-RJ)/MR-J4-DU37KA(-RJ)

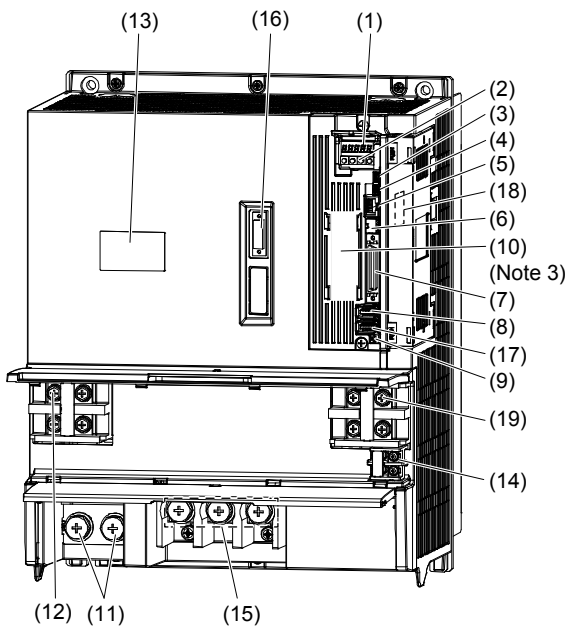

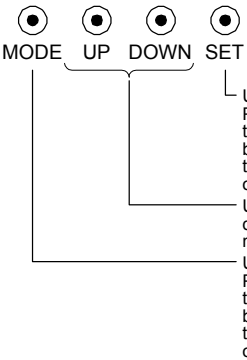
No.	Name/Application	Detailed explanation
(1)	Display The 5-digit, 7-segment LED display shows the drive unit status and the alarm number.	MR-J4-_A_ Section 4.5
(2)	Operation section Used to perform status display, diagnostic, alarm, and parameter setting operations.  <p>MODE UP DOWN SET</p> <p>Used to set data. Push this button together with the "MODE" button for 3 s or more to switch to the one-touch tuning mode.</p> <p>Used to change the display or data in each mode.</p> <p>Used to change the mode. Push this button together with the "SET" button for 3 s or more to switch to the one-touch tuning mode.</p>	MR-J4-_A_ Section 4.5
(3)	USB communication connector (CN5) Used to connect the personal computer.	MR-J4-_A_ Section 11.7
(4)	Analog monitor connector (CN6) Used to output the analog monitor.	MR-J4-_A_ Section 3.2
(5)	RS-422/RS-485 communication connector (CN3) Used to connect the personal computer, etc.	MR-J4-_A_ Chapter 14
(6)	STO input signal connector (CN8) Used to connect the MR-J3-D05 safety logic unit and external safety relay.	MR-J4-_A_ Chapter 13 App. 5
(7)	I/O signal connector (CN1) Used to connect digital I/O signals.	MR-J4-_A_ Section 3.2 Section 3.4
(8) (Note 2)	Encoder connector (CN2) Used to connect the servo motor encoder or external encoder. Refer to table 1.1 for the compatible external encoders.	MR-J4-_A_ Section 3.4 "Servo Motor Instruction Manual (Vol. 3)"
(9)	Battery connector (CN4) Used to connect the battery for absolute position data backup.	MR-J4-_A_ Chapter 12
(10)	Battery holder Used to house the battery for absolute position data backup.	MR-J4-_A_ Section 12.2
(11)	Protective earth (PE) terminal Grounding terminal	Section 3.1 Section 3.2
(12)	L+/L- terminal (TE2-1) Used to connect the L+ and L- terminals of the converter unit using the bus bars supplied.	
(13)	Rating plate	Section 1.4
(14)	Control circuit terminal L11/L21 (TE3) Used to connect the control circuit power supply.	Section 3.1 Section 3.2
(15)	Servo motor power output terminal (TE1) Used to connect the servo motor.	
(16)	Protection coordination connector (CN40A) Used to connect CN40 of the converter unit.	Section 3.1
(17) (Note 1)	External encoder connector (CN2L) (Note 2) Used to connect the external encoder. Refer to table 1.1 for the compatible external encoders.	"Linear Encoder Instruction Manual"
(18)	Manufacturer setting connector (CN7) This connector is attached on the MR-J4-DU_A_-RJ drive unit, but not for use. The MR-J4-DU_A_ drive unit does not have this connector.	
(19)	Manufacturer setting terminal (TE2-2) This is for manufacturer setting. Leave this open.	

Note 1. This is for the MR-J4-DU_A_-RJ drive unit. The MR-J4-DU_A_ drive unit does not have the CN2L connector.

2. "External encoder" is a term for the load-side encoder used in the fully closed loop system and the scale measurement encoder used with the scale measurement function in this manual.

3. Lines for slots around the battery holder are omitted from the illustration.

1. FUNCTIONS AND CONFIGURATION

2) 400 V class

a) MR-J4-DU30KA4(-RJ)/MR-J4-DU37KA4(-RJ)

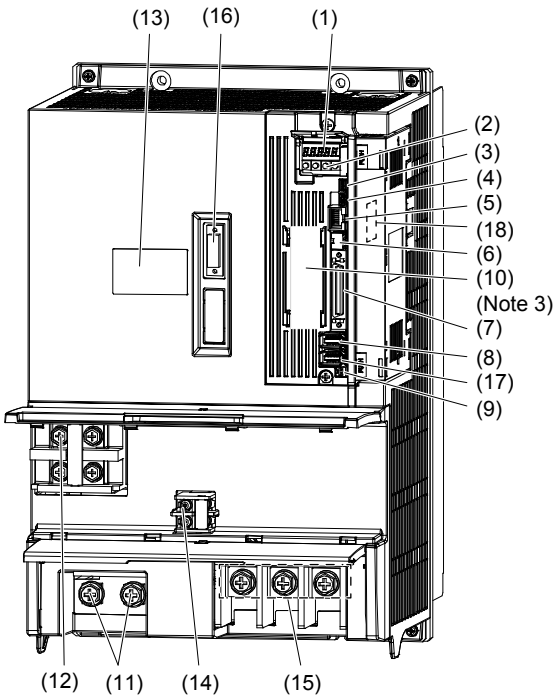

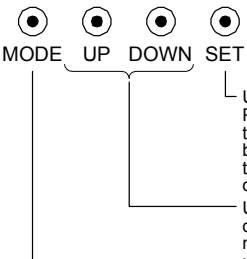
No.	Name/Application	Detailed explanation
(1)	Display The 5-digit, 7-segment LED display shows the drive unit status and the alarm number.	MR-J4-_A_ Section 4.5
(2)	Operation section Used to perform status display, diagnostic, alarm, and parameter setting operations.  <p>MODE UP DOWN SET</p> <p>Used to set data. Push this button together with the "MODE" button for 3 s or more to switch to the one-touch tuning mode.</p> <p>Used to change the display or data in each mode.</p> <p>Used to change the mode. Push this button together with the "SET" button for 3 s or more to switch to the one-touch tuning mode.</p>	MR-J4-_A_ Section 4.5
(3)	USB communication connector (CN5) Used to connect the personal computer.	MR-J4-_A_ Section 11.7
(4)	Analog monitor connector (CN6) Used to output the analog monitor.	MR-J4-_A_ Section 3.2
(5)	RS-422/RS-485 communication connector (CN3) Used to connect the personal computer, etc.	MR-J4-_A_ Chapter 14
(6)	STO input signal connector (CN8) Used to connect the MR-J3-D05 safety logic unit and external safety relay.	MR-J4-_A_ Chapter 13 App. 5
(7)	I/O signal connector (CN1) Used to connect digital I/O signals.	MR-J4-_A_ Section 3.2 Section 3.4
(8) (Note 2)	Encoder connector (CN2) Used to connect the servo motor encoder or external encoder. Refer to table 1.1 for the compatible external encoders.	MR-J4-_A_ Section 3.4 "Servo Motor Instruction Manual (Vol. 3)"
(9)	Battery connector (CN4) Used to connect the battery for absolute position data backup.	MR-J4-_A_ Chapter 12
(10)	Battery holder Used to house the battery for absolute position data backup.	MR-J4-_A_ Section 12.2
(11)	Protective earth (PE) terminal Grounding terminal	Section 3.1 Section 3.2
(12)	L+/L- terminal (TE2-1) Used to connect the L+ and L- terminals of the converter unit using the bus bars supplied.	
(13)	Rating plate	Section 1.4
(14)	Control circuit terminal L11/L21 (TE3) Used to connect the control circuit power supply.	Section 3.1 Section 3.2
(15)	Servo motor power output terminal (TE1) Used to connect the servo motor.	
(16)	Protection coordination connector (CN40A) Used to connect CN40 of the converter unit.	Section 3.1
(17) (Note 1)	External encoder connector (CN2L) (Note 2) Used to connect the external encoder. Refer to table 1.1 for the compatible external encoders.	"Linear Encoder Instruction Manual"
(18)	Manufacturer setting connector (CN7) This connector is attached on the MR-J4-DU_A_-RJ drive unit, but not for use. The MR-J4-DU_A_ drive unit does not have this connector.	

Note 1. This is for the MR-J4-DU_A_-RJ drive unit. The MR-J4-DU_A_ drive unit does not have the CN2L connector.

Note 2. "External encoder" is a term for the load-side encoder used in the fully closed loop system and the scale measurement encoder used with the scale measurement function in this manual.

Note 3. Lines for slots around the battery holder are omitted from the illustration.

1. FUNCTIONS AND CONFIGURATION

b) MR-J4-DU45KA4(-RJ)/MR-J4-DU55KA4(-RJ)

The broken line area is the same as MR-J4-DU30KA4(-RJ)/MRJ4-DU37KA4(-RJ).

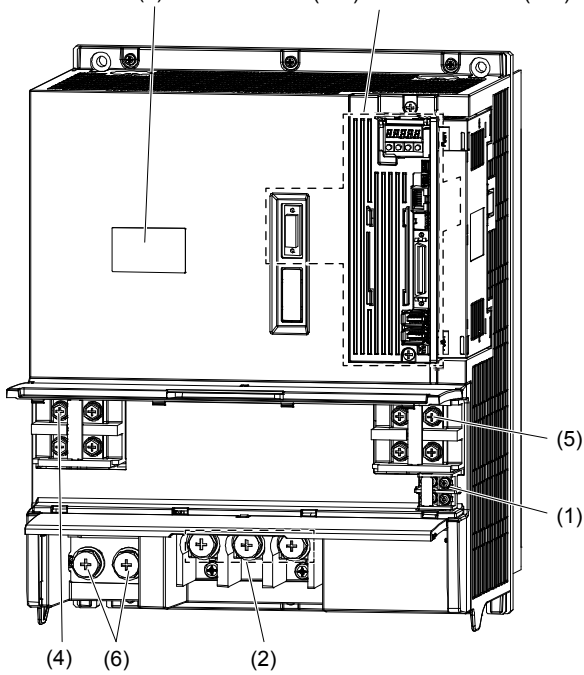

No.	Name/Application	Detailed explanation
(1)	Control circuit terminal L11/L21 (TE3) Used to connect the control circuit power supply.	Section 3.1 Section 3.2
(2)	Servo motor power output terminal (TE1) Used to connect the servo motor.	
(3)	Rating plate	Section 1.4
(4)	L+/L- terminal (TE2-1) Used to connect the L+ and L- terminals of the converter unit using the bus bars supplied.	Section 3.1 Section 3.2
(5)	Manufacturer setting terminal (TE2-2) This is for manufacturer setting. Leave this open.	
(6)	Protective earth (PE) terminal Grounding terminal	Section 3.1 Section 3.2

1. FUNCTIONS AND CONFIGURATION

(b) MR-J4-DU_B_(-RJ)

"MR-J4-_B_" means "MR-J4-_B_(-RJ) Servo Amplifier Instruction Manual".

1) 200 V class

a) MR-J4-DU30KB(-RJ)/MR-J4-DU37KB(-RJ)

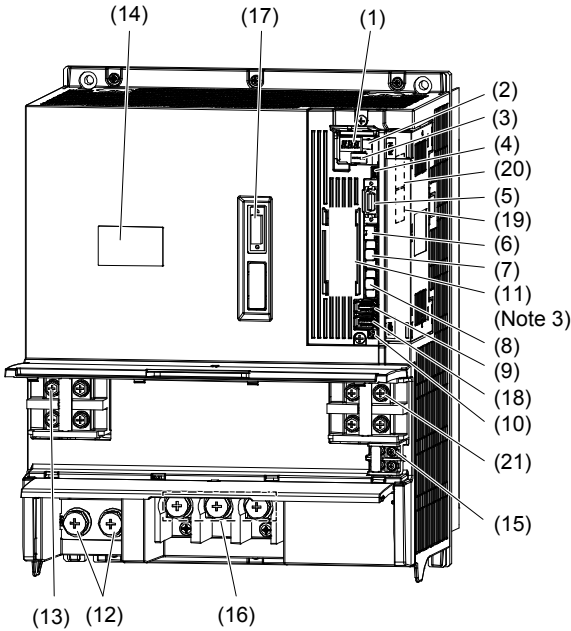

No.	Name/Application	Detailed explanation
(1)	Display The 3-digit, 7-segment LED display shows the drive unit status and the alarm number.	MR-J4-_B_ Section 4.3
(2)	Axis selection rotary switch (SW1) Used to set the axis No. of the drive unit.	
(3)	Control axis setting switch (SW2) Consists of the test operation switch, control axis deactivation setting switch, and auxiliary axis number setting switch.	
(4)	USB communication connector (CN5) Used to connect the personal computer.	MR-J4-_B_ Section 11.7
(5)	I/O signal connector (CN3) Used to connect digital I/O signals.	MR-J4-_B_ Section 3.2 Section 3.4
(6)	STO input signal connector (CN8) Used to connect the MR-J3-D05 safety logic unit and external safety relay.	MR-J4-_B_ Chapter 13 App. 5
(7)	SSCNET III cable connector (CN1A) Used to connect the servo system controller or the previous axis servo amplifier.	MR-J4-_B_ Section 3.2 Section 3.4
(8)	SSCNET III cable connector (CN1B) Used to connect the next axis servo amplifier. For the final axis, put a cap.	
(9) (Note 2)	Encoder connector (CN2) Used to connect the servo motor encoder or external encoder. Refer to table 1.1 for the compatible external encoders.	MR-J4-_B_ Section 3.4 "Servo Motor Instruction Manual (Vol. 3)"
(10)	Battery connector (CN4) Used to connect the battery for absolute position data backup.	MR-J4-_B_ Chapter 12
(11)	Battery holder Used to house the battery for absolute position data backup.	MR-J4-_B_ Section 12.2
(12)	Protective earth (PE) terminal Grounding terminal	Section 3.1 Section 3.2
(13)	L+/L- terminal (TE2-1) Used to connect the L+ and L- terminals of the converter unit using the bus bars supplied.	
(14)	Rating plate	Section 1.4
(15)	Control circuit terminal L11/L21 (TE3) Used to connect the control circuit power supply.	Section 3.1 Section 3.2
(16)	Servo motor power output terminal (TE1) Used to connect the servo motor.	
(17)	Protection coordination connector (CN40A) Used to connect CN40 of the converter unit.	Section 3.1
(18) (Note 1)	External encoder connector (CN2L) (Note 2) Used to connect the external encoder. Refer to table 1.1 for the compatible external encoders.	"Linear Encoder Instruction Manual"
(19)	Manufacturer setting connector (CN7) This connector is attached on the MR-J4-DU_B_-RJ drive unit, but not for use. The MR-J4-DU_B_ drive unit does not have this connector.	
(20)	Manufacturer setting connector (CN9) This connector is attached on the MR-J4-DU_B_-RJ drive unit, but not for use. The MR-J4-DU_B_ drive unit does not have this connector.	
(21)	Manufacturer setting terminal (TE2-2) This is for manufacturer setting. Leave this open.	

- Note 1. This is for the MR-J4-DU_B_-RJ drive unit. The MR-J4-DU_B_ drive unit does not have the CN2L connector.
- Note 2. "External encoder" is a term for the load-side encoder used in the fully closed loop system and the scale measurement encoder used with the scale measurement function in this manual.
- Note 3. Lines for slots around the battery holder are omitted from the illustration.

1. FUNCTIONS AND CONFIGURATION

2) 400 V class

a) MR-J4-DU30KB4(-RJ)/MR-J4-DU37KB4(-RJ)

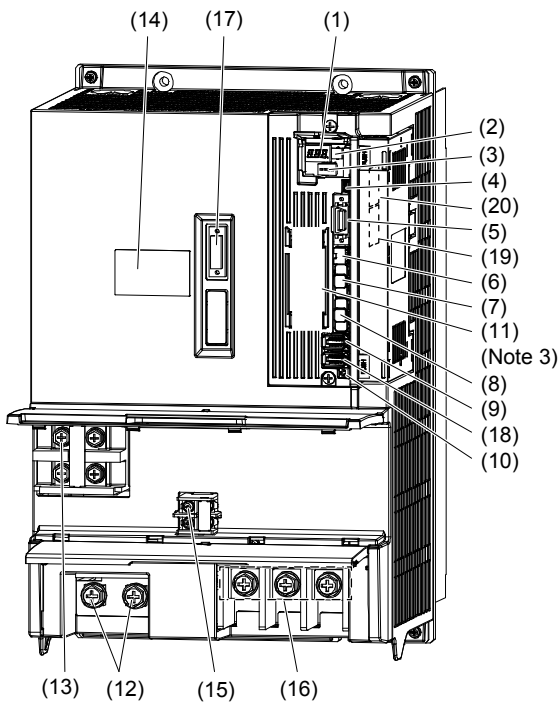

No.	Name/Application	Detailed explanation
(1)	Display The 3-digit, 7-segment LED display shows the drive unit status and the alarm number.	MR-J4-_B_ Section 4.3
(2)	Axis selection rotary switch (SW1) Used to set the axis No. of the drive unit.	
(3)	Control axis setting switch (SW2) Consists of the test operation switch, control axis deactivation setting switch, and auxiliary axis number setting switch.	
(4)	USB communication connector (CN5) Used to connect the personal computer.	MR-J4-_B_ Section 11.7
(5)	I/O signal connector (CN3) Used to connect digital I/O signals.	MR-J4-_B_ Section 3.2 Section 3.4
(6)	STO input signal connector (CN8) Used to connect the MR-J3-D05 safety logic unit and external safety relay.	MR-J4-_B_ Chapter 13 App. 5
(7)	SSCNET III cable connector (CN1A) Used to connect the servo system controller or the previous axis servo amplifier.	MR-J4-_B_ Section 3.2 Section 3.4
(8)	SSCNET III cable connector (CN1B) Used to connect the next axis servo amplifier. For the final axis, put a cap.	
(9) (Note 2)	Encoder connector (CN2) Used to connect the servo motor encoder or external encoder. Refer to table 1.1 for the compatible external encoders.	MR-J4-_B_ Section 3.4 "Servo Motor Instruction Manual (Vol. 3)"
(10)	Battery connector (CN4) Used to connect the battery for absolute position data backup.	MR-J4-_B_ Chapter 12
(11)	Battery holder Used to house the battery for absolute position data backup.	MR-J4-_B_ Section 12.4
(12)	Protective earth (PE) terminal Grounding terminal	Section 3.1 Section 3.2
(13)	L+/L- terminal (TE2-1) Used to connect the L+ and L- terminals of the converter unit using the bus bars supplied.	
(14)	Rating plate	Section 1.4
(15)	Control circuit terminal L11/L21 (TE3) Used to connect the control circuit power supply.	Section 3.1 Section 3.2
(16)	Servo motor power output terminal (TE1) Used to connect the servo motor.	
(17)	Protection coordination connector (CN40A) Used to connect CN40 of the converter unit.	Section 3.1
(18) (Note 1)	External encoder connector (CN2L) (Note 2) Used to connect the external encoder. Refer to table 1.1 for the compatible external encoders.	"Linear Encoder Instruction Manual"
(19)	Manufacturer setting connector (CN7) This connector is attached on the MR-J4-DU_B_-RJ drive unit, but not for use. The MR-J4-DU_B_ drive unit does not have this connector.	
(20)	Manufacturer setting connector (CN9) This connector is attached on the MR-J4-DU_B_-RJ drive unit, but not for use. The MR-J4-DU_B_ drive unit does not have this connector.	

- Note 1. This is for the MR-J4-DU_B_-RJ drive unit. The MR-J4-DU_B_ drive unit does not have the CN2L connector.
- Note 2. "External encoder" is a term for the load-side encoder used in the fully closed loop system and the scale measurement encoder used with the scale measurement function in this manual.
- Note 3. Lines for slots around the battery holder are omitted from the illustration.

1. FUNCTIONS AND CONFIGURATION

b) MR-J4-DU45KB4(-RJ)/MR-J4-DU55KB4(-RJ)

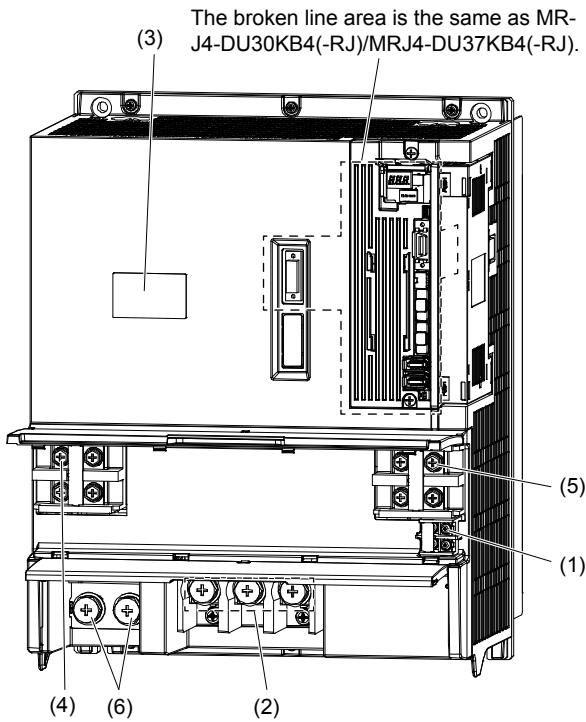

No.	Name/Application	Detailed explanation
(1)	Control circuit terminal L11/L21 (TE3) Used to connect the control circuit power supply.	Section 3.1 Section 3.2
(2)	Servo motor power output terminal (TE1) Used to connect the servo motor.	Section 3.2
(3)	Rating plate	Section 1.4
(4)	L+/L- terminal (TE2-1) Used to connect the L+ and L- terminals of the converter unit using the bus bars supplied.	Section 3.1 Section 3.2
(5)	Manufacturer setting terminal (TE2-2) This is for manufacturer setting. Leave this open.	
(6)	Protective earth (PE) terminal Grounding terminal	Section 3.1 Section 3.2

1. FUNCTIONS AND CONFIGURATION

1.5.2 Opening and closing of the terminal block cover

WARNING

● Before opening or closing the terminal block cover, turn off the power and wait for 20 minutes or more until the charge lamp turns off. Then, confirm that the voltage between L+ and L- is safe with a voltage tester or others. Otherwise, an electric shock may occur. In addition, always confirm that the charge lamp is off from the front of the converter unit.

The following shows how to open and close the terminal block cover using illustrations of converter units as an example. For a drive unit, the shape of the main unit is different. However, the terminal block cover can be opened or closed in the same procedure.

- (1) Upper terminal block cover
(a) How to open

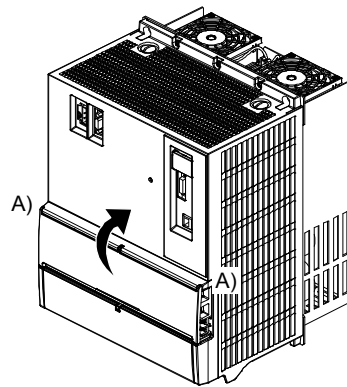

1) Pull up the cover using point A) as a support.

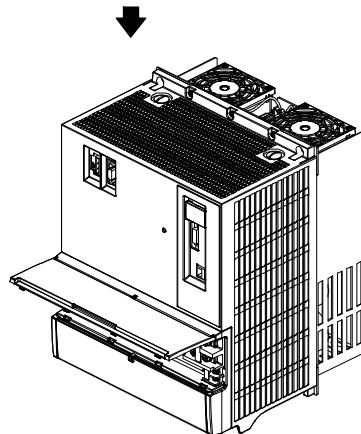

2) The cover is fixed when pulled up to the position as shown in the illustration.

1. FUNCTIONS AND CONFIGURATION

(b) How to close

1) Close the cover using point A) as a support.

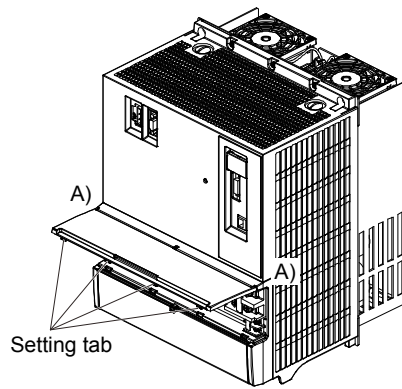

2) Press the cover against the terminal box until the installing knobs click.

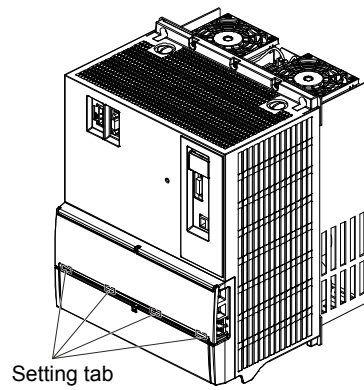

1. FUNCTIONS AND CONFIGURATION

- (2) Lower terminal block cover
(a) How to open

1) Hold the bottom of the terminal block cover with both hands.

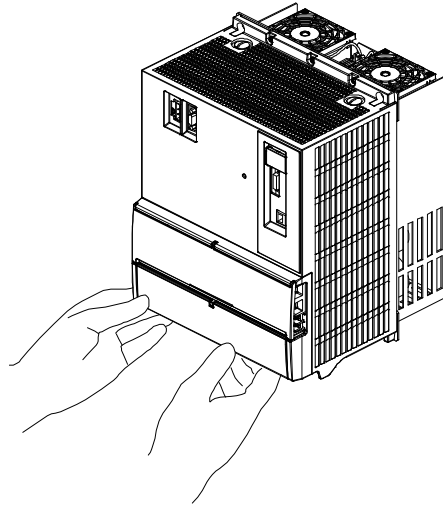

2) Pull up the cover using point B) as a support.

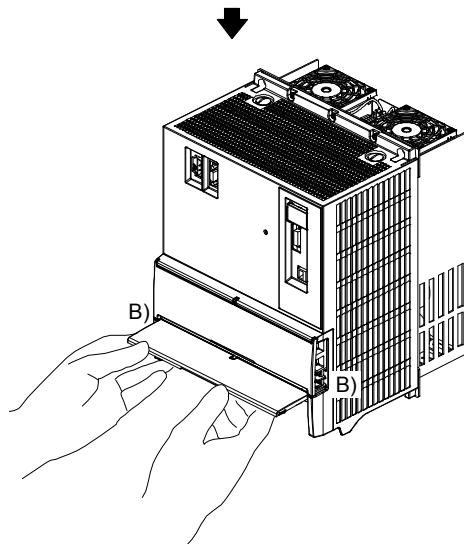

3) The cover is fixed when pulled up to the top.

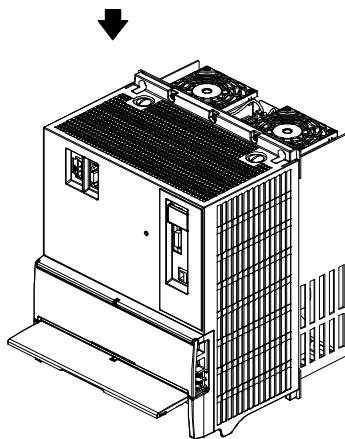

1. FUNCTIONS AND CONFIGURATION

(b) How to close

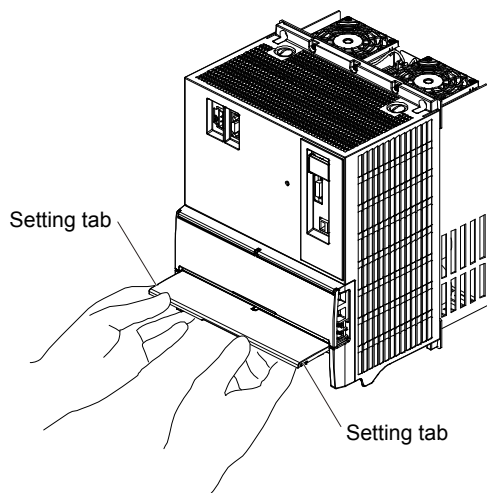

1) Hold the bottom of the terminal block cover with both hands.

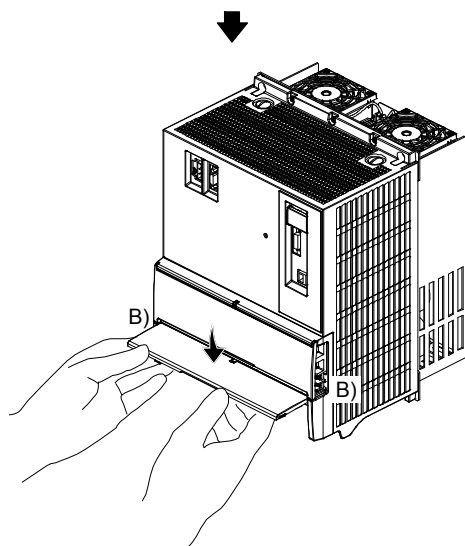

2) Close the cover using point B) as a support.

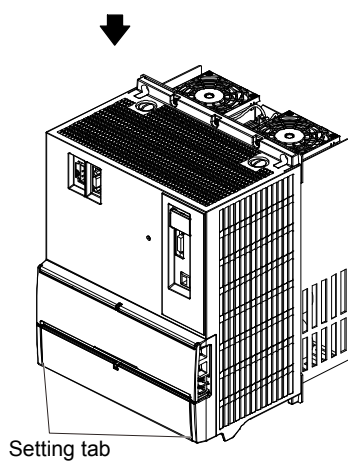

3) Press the cover against the terminal box until the installing knobs click.

1. FUNCTIONS AND CONFIGURATION

1.6 Configuration including peripheral equipment

The diagram shows MR-J4-DU30KB4 and MR-J4-DU37KB4. The connection for the interface of MR-J4-DU_(-RJ) is the same as in the case of MR-J4_(-RJ). Refer to each servo amplifier instruction manual.

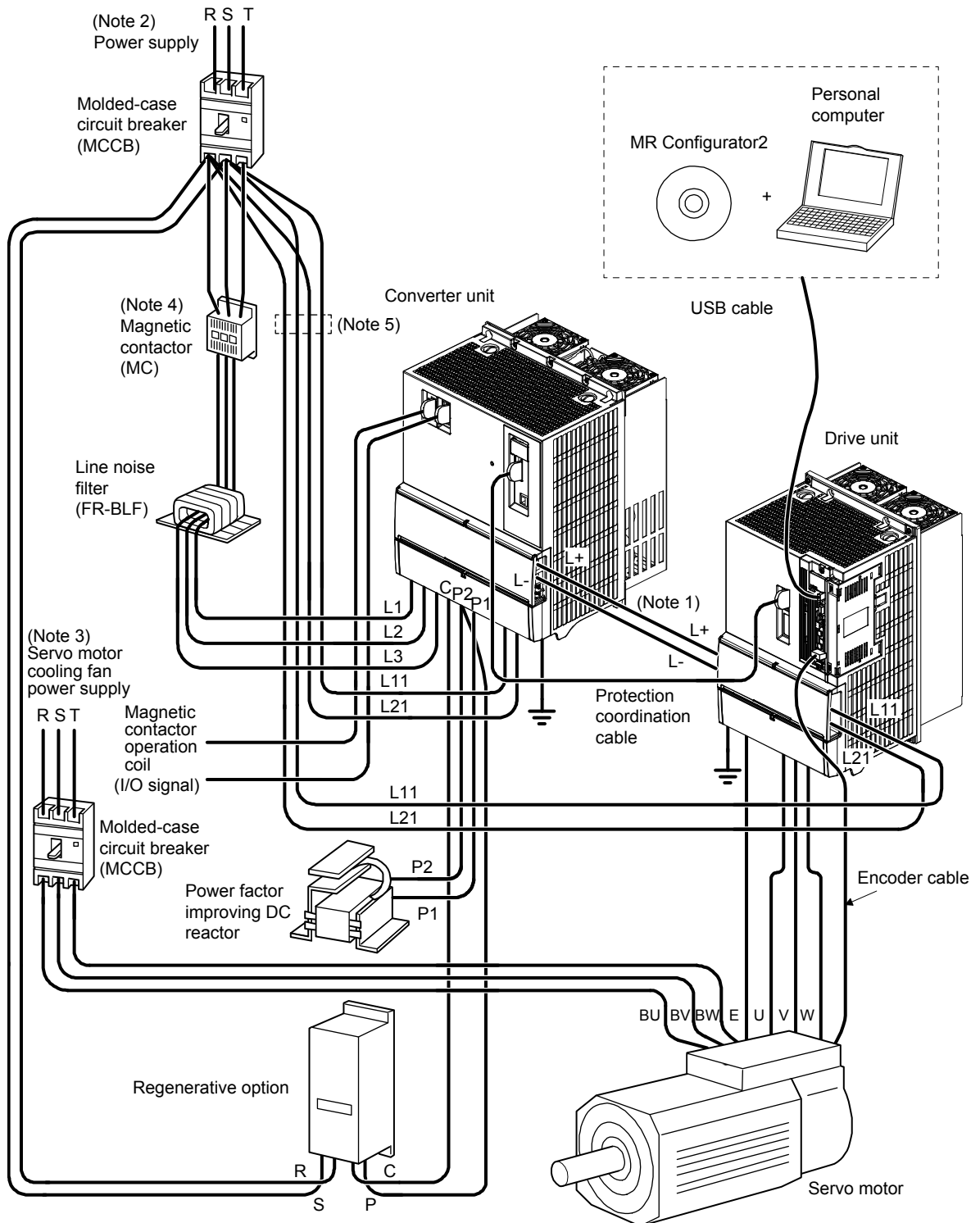

- Note 1. The L+ and L- bus bars used to connect a converter unit to a drive unit are standard accessories. The converter unit is actually attached to the drive unit.
- Note 2. For the power supply specifications, refer to section 1.2.
- Note 3. For specifications of the cooling fan power supply, refer to "Servo Motor Instruction Manual (Vol. 3)".
- Note 4. The bus voltage decreases depending on the main circuit voltage and operation pattern, which may cause the forced stop deceleration to shift to the dynamic brake deceleration. When dynamic brake deceleration is not required, slow the time to turn off the magnetic contactor.
- Note 5. Install an overcurrent protection device (molded-case circuit breaker or fuse) to protect the branch circuit. (Refer to section 9.5.)

2. INSTALLATION

2. INSTALLATION

 **WARNING** ● To prevent electric shock, ground equipment securely.

 **CAUTION**

- Stacking in excess of the specified number of product packages is not allowed.
- Install the equipment on incombustible material. Installing them directly or close to combustibles will lead to a fire.
- Install the converter unit, the drive unit, and the servo motor in a load-bearing place in accordance with the Instruction Manual.
- Do not get on or put heavy load on the equipment. Otherwise, it may cause injury.
- Use the equipment within the specified environment. For the environment, refer to section 1.2.
- Provide adequate protection to prevent screws and other conductive matter, oil and other combustible matter from entering the converter unit and the drive unit.
- Do not block intake and exhaust areas of the converter unit and the drive unit. Otherwise, it may cause a malfunction.
- Do not drop or strike the converter unit and the drive unit. Isolate them from all impact loads.
- Do not install or operate the converter unit and the drive unit which have been damaged or have any parts missing.
- When the product has been stored for an extended period of time, contact your local sales office.
- When handling the converter unit and the drive unit, be careful about the edged parts such as corners of the converter unit and drive unit.
- The converter unit and the drive unit must be installed in the metal cabinet.
- When fumigants that contain halogen materials such as fluorine, chlorine, bromine, and iodine are used for disinfecting and protecting wooden packaging from insects, they cause malfunction when entering our products. Please take necessary precautions to ensure that remaining materials from fumigant do not enter our products, or treat packaging with methods other than fumigation, such as heat treatment. Additionally, disinfect and protect wood from insects before packing products.

The following items are the same as those of MR-J4-_-(-RJ). For details of the items, refer to each chapter/section indicated in the detailed explanation field. "MR-J4-_A_" means "MR-J4-_A_(-RJ) Servo Amplifier Instruction Manual". "MR-J4-_B_" means "MR-J4-_B_(-RJ) Servo Amplifier Instruction Manual".

Model	Item	Detailed explanation
MR-J4-DU_A_(-RJ)	Encoder cable stress	MR-J4-_A_ section 2.3
MR-J4-DU_B_(-RJ)	Encoder cable stress	MR-J4-_B_ section 2.3
	SSCNET III cable laying	MR-J4-_B_ section 2.4

2. INSTALLATION

2.1 Installation direction and clearances



CAUTION

- The equipment must be installed in the specified direction. Otherwise, it may cause a malfunction.
- Leave the specified clearances between the converter unit/drive unit and the cabinet walls or other equipment. Otherwise, it may cause a malfunction.

(1) Installation

POINT

- Make sure to connect a drive unit to the right side of a converter unit as shown in the diagram.

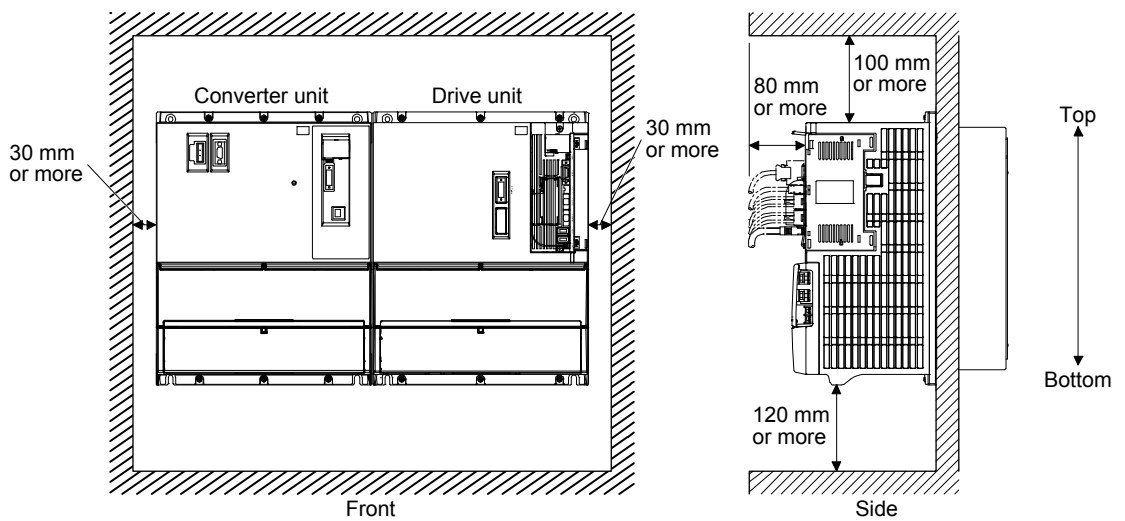

2. INSTALLATION

(2) Mounting hole process drawing

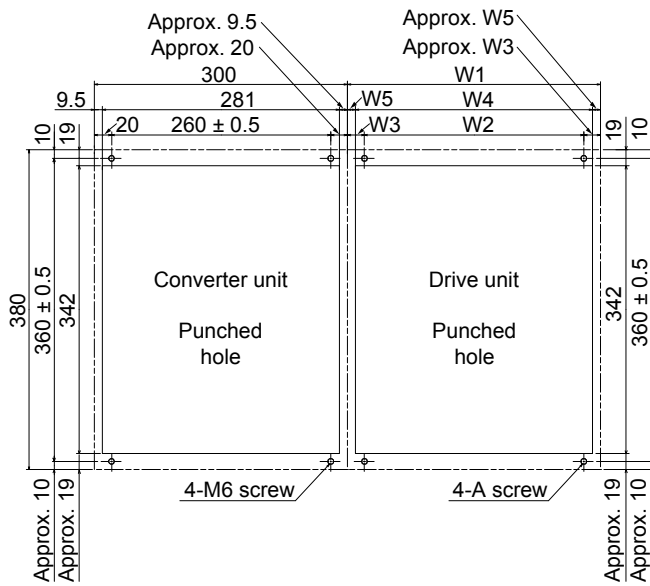

Drive unit	Variable dimensions [mm]					Screw size
	W1	W2	W3	W4	W5	
MR-J4-DU30K_(-RJ)	300	260 ± 0.5	20	281	9.5	M6
MR-J4-DU37K_(-RJ)						
MR-J4-DU45K_4(-RJ)						
MR-J4-DU55K_4(-RJ)						
MR-J4-DU30K_4(-RJ)	240	120 ± 0.5	60	222	9	M5
MR-J4-DU37K_4(-RJ)						

(3) Others

When using heat generating equipment such as the regenerative option, install them with full consideration of heat generation so that the converter unit and drive unit are not affected. Install the converter unit and drive unit on a perpendicular wall in the correct vertical direction.

2. INSTALLATION

2.2 Keeping out of foreign materials

- (1) When drilling in the cabinet, prevent drill chips and wire fragments from entering the converter unit and the drive unit.
- (2) Prevent oil, water, metallic dust, etc. from entering the converter unit and the drive unit through openings in the cabinet or a cooling fan installed on the ceiling.
- (3) When installing the cabinet in a place where toxic gas, dirt and dust exist, conduct an air purge (that forces clean air into the cabinet from outside to make the internal pressure higher than the external pressure) to prevent such materials from entering the cabinet.

2.3 Inspection items

WARNING

- Before starting maintenance and/or inspection, turn off the power and wait for 20 minutes or more until the charge lamp turns off. Then, confirm that the voltage between L+ and L- is safe with a voltage tester or others. Otherwise, an electric shock may occur. In addition, always confirm that the charge lamp is off from the front of the converter unit.
- To avoid an electric shock, only qualified personnel should attempt inspections. For repair and parts replacement, contact your local sales office.

CAUTION

- Do not perform insulation resistance test on the converter unit and the drive unit. Otherwise, it may cause a malfunction.
- Do not disassemble and/or repair the equipment on customer side.

It is recommended that the following points be checked periodically.

- (1) Check for loose terminal block screws. Retighten any loose screws.
- (2) Check for scratches and cracks of cables and the like. Inspect them periodically according to operating conditions especially when the servo motor is movable.
- (3) Check that the connectors are securely connected to the converter unit and the drive unit.
- (4) Check that the wires are not coming out from the connector.
- (5) Check for dust accumulation on the converter unit and the drive unit.
- (6) Check for unusual noise generated from the converter unit and the drive unit.

2. INSTALLATION

2.4 Parts having service lives

Service lives of the following parts are listed below. However, the service life varies depending on operating methods and environment. If any fault is found in the parts, they must be replaced immediately regardless of their service lives. For parts replacement, please contact your local sales office.

Part name	Life guideline
Smoothing capacitor	10 years
Relay	Number of power-on, forced stop by EM1 (Forced stop 1), controller forced stop, and on/off for STO: 100,000 times
Cooling fan	10,000 hours to 30,000 hours (2 years to 3 years)
Absolute position battery	Refer to each servo amplifier instruction manual.

(1) Smoothing capacitor

The characteristic of smoothing capacitor is deteriorated due to ripple currents, etc. The life of the capacitor greatly depends on ambient temperature and operating conditions. The capacitor will reach the end of its life in 10 years of continuous operation in air-conditioned environment (40 °C surrounding air temperature or less).

(2) Relays

Contact faults will occur due to contact wear arisen from switching currents. Relays reach the end of their lives when the number of power-on, forced stop by EM1 (Forced stop 1), controller forced stop, and on/off for STO while the servo motor is stopped under servo-off state reaches 100,000 times. However, the lives of relays may depend on the power supply capacity.

(3) Cooling fan

The cooling fan bearings reach the end of their lives in 10,000 hours to 30,000 hours. Therefore, the cooling fan normally must be replaced in a few years of continuous operation as a guideline. It must also be changed if unusual noise or vibration is found during inspection.

The life is calculated under the annual average ambient temperature of 40 °C, free from corrosive gas, flammable gas, oil mist, dust and dirt.

2. INSTALLATION

2.5 Restrictions when using the servo amplifiers at altitude exceeding 1000 m and up to 2000 m over sea level

(1) Effective load ratio and regenerative load ratio

Heat dissipation effects decrease in proportion to decreasing air density, and hence use the servo amplifiers with the effective load ratio and the regenerative load ratio within the following range.

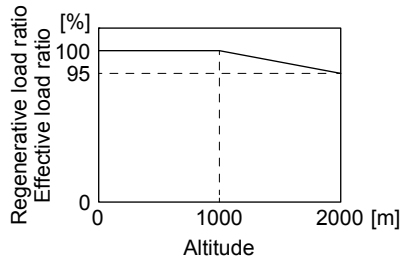

(2) Input voltage

Generally, withstand voltage decreases as increasing altitude; however, there is no restriction on the withstand voltage. Use in the same manner as in 1000 m or less. (Refer to section 1.2.)

(3) Parts having service lives

(a) Smoothing capacitor

The capacitor will reach the end of its life in 10 years of continuous operation in air-conditioned environment (30 °C surrounding air temperature or less).

(b) Relays

There is no restriction. Use in the same manner as in 1000 m or less. (Refer to section 2.4.)

(c) Servo amplifier cooling fan

There is no restriction. Use in the same manner as in 1000 m or less. (Refer to section 2.4.)

3. SIGNALS AND WIRING

3. SIGNALS AND WIRING

⚠ WARNING

- A person who is involved in wiring should be fully competent to do the work.
- Before wiring, turn off the power and wait for 15 minutes or more until the charge lamp turns off. Then, confirm that the voltage between L+ and L- is safe with a voltage tester or others. Otherwise, an electric shock may occur. In addition, always confirm that the charge lamp is off from the front of the converter unit.
- Ground the converter unit, the drive unit and the servo motor securely.
- Do not attempt to wire the converter unit, the drive unit, and the servo motor until they have been installed. Otherwise, it may cause an electric shock.
- The cables should not be damaged, stressed, loaded, or pinched. Otherwise, it may cause an electric shock.
- To avoid an electric shock, insulate the connections of the power supply terminals.

- Wire the equipment correctly and securely. Otherwise, the servo motor may operate unexpectedly, resulting in injury.
- Connect cables to the correct terminals. Otherwise, a burst, damage, etc. may occur.
- Ensure that polarity (+/-) is correct. Otherwise, a burst, damage, etc. may occur.
- The surge absorbing diode installed to the DC relay for control output should be fitted in the specified direction. Otherwise, the emergency stop and other protective circuits may not operate.

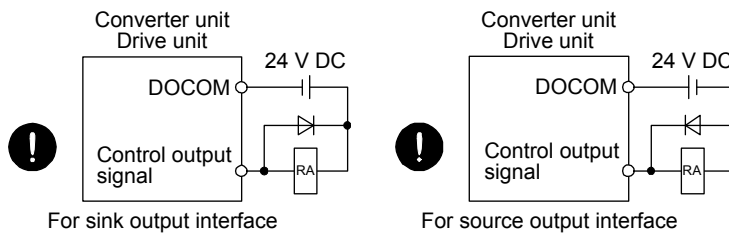

⚠ CAUTION

- Use a noise filter, etc. to minimize the influence of electromagnetic interference. Electromagnetic interference may be given to the electronic equipment used near the converter unit and the drive unit.
- Do not install a power capacitor, surge killer or radio noise filter (optional FR-BIF-(H)) with the power line of the servo motor.
- When using the regenerative resistor, switch power off with the alarm signal. Otherwise, a transistor fault or the like may overheat the regenerative resistor, causing a fire.
- Do not modify the equipment.
- Connect the drive unit power outputs (U, V, and W) to the servo motor power inputs (U, V, and W) directly. Do not let a magnetic contactor, etc. intervene. Otherwise, it may cause a malfunction.

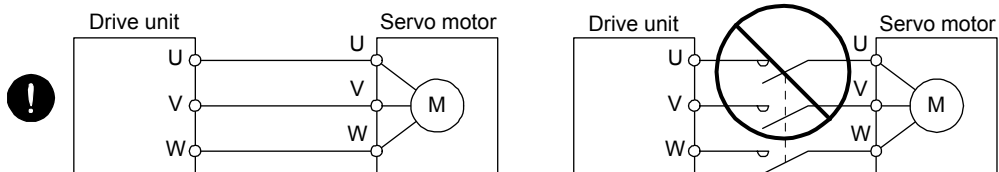

- Do not connect the servo motor of a wrong axis to U, V, W, or CN2 of the drive unit. Otherwise, a malfunction may occur.

3. SIGNALS AND WIRING

The following items are the same as those of MR-J4-_-(-RJ). For details of the items, refer to each chapter/section indicated in the detailed explanation field. "MR-J4-_A_" means "MR-J4-_A_(-RJ) Servo Amplifier Instruction Manual". "MR-J4-_B_" means "MR-J4-_B_(-RJ) Servo Amplifier Instruction Manual".

Model	Item	Detailed explanation
MR-J4-DU_A_(-RJ)	I/O signal connection example	MR-J4-_A_ section 3.2
	Forced stop deceleration function	MR-J4-_A_ section 3.7
MR-J4-DU_B_(-RJ)	I/O signal connection example	MR-J4-_B_ section 3.2
	Forced stop deceleration function	MR-J4-_B_ section 3.6
	SSCNET III cable connection	MR-J4-_B_ section 3.9

3.1 Input power supply circuit

 WARNING	<ul style="list-style-type: none"> ● Insulate the connections of the power supply terminals. Otherwise, an electric shock may occur. ● Always connect the magnetic contactor wiring connector to CNP1 of the converter unit. If the connector is not connected, an electric shock may occur.
--	--

 CAUTION	<ul style="list-style-type: none"> ● Always connect the magnetic contactor between the power supply and the main circuit power supply (L1, L2, and L3) of the converter unit, in order to configure a circuit that shuts down the power supply on the side of the converter unit power supply. If the magnetic contactor is not connected, a large current keeps flowing and may cause a fire when the converter unit or the drive unit malfunctions. ● Use ALM (Malfunction) to switch power off. Not doing so may cause a fire when a regenerative transistor malfunctions or the like may overheat the regenerative resistor. ● The converter unit has a built-in surge absorber (varistor) to reduce noise and to suppress lightning surge. The varistor can break down due to its aged deterioration. To prevent a fire, use a molded-case circuit breaker or fuse for input power supply. ● Do not connect the servo motor of a wrong axis to U, V, W, or CN2 of the drive unit. Otherwise, a malfunction may occur. ● Check the converter unit model, and then input proper voltage to the converter unit power supply. If input voltage exceeds the upper limit, the converter unit and the drive unit will break down.
--	--

POINT	<ul style="list-style-type: none"> ● For drive units, EM2 has the same function as EM1 in the torque control mode. ● For the MR-J4-DU_B_(-RJ) drive units, do not switch off the control circuit power supply even though an alarm occurs. When the control circuit power supply is switched off, optical module does not operate, and optical transmission of SSCNET III/H communication is interrupted. Therefore, the next axis servo amplifier and the drive unit display "AA" at the indicator and turn into base circuit shut-off. The dynamic brake operates, bringing the servo motor to a stop.
--------------	--

3. SIGNALS AND WIRING

3.1.1 Magnetic contactor control connector (CNP1)

 CAUTION	<p>● Always connect the magnetic contactor wiring connector to the converter unit. If the connector is not connected, an electric shock may occur since CNP1-1 and L11 are always conducting.</p>
--	---

By enabling magnetic contactor drive output, the main circuit power supply can be shut off automatically when an alarm occurs in the converter unit or the drive unit.

To enable magnetic contactor drive output, set [Pr. PA02] of the converter unit to "___ 1" (initial value).

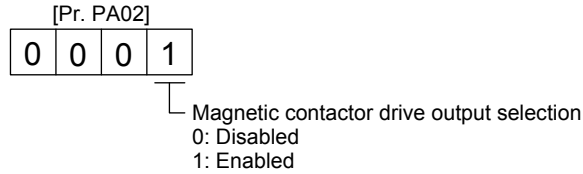

(1) When magnetic contactor drive output is enabled

To control the magnetic contactor, connect the magnetic contactor control connector (CNP1) to the coil of the magnetic contactor.

Internal connection diagram of CNP1

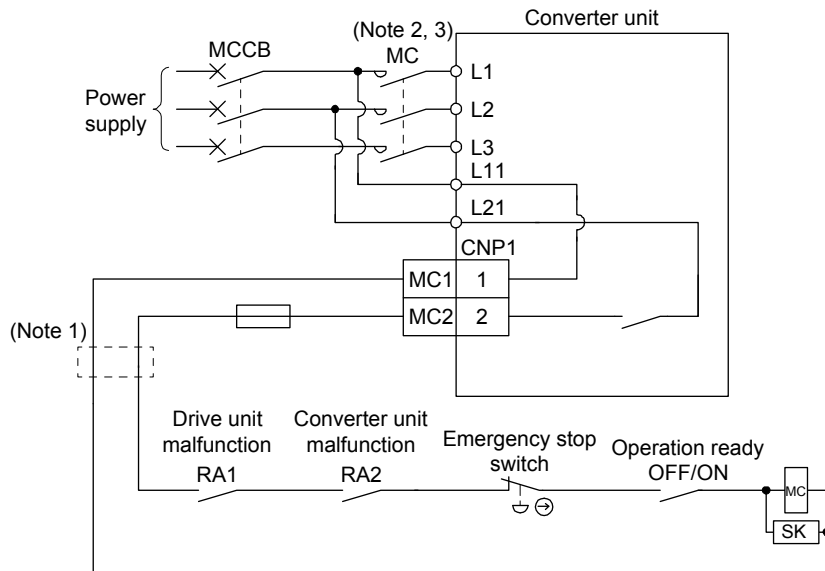

- Note 1. A step-down transformer is required when coil voltage of the magnetic contactor is 200 V class, and the converter unit and the drive unit are 400 V class.
- Note 2. The bus voltage decreases depending on the main circuit voltage and operation pattern, which may cause the forced stop deceleration to shift to the dynamic brake deceleration. When dynamic brake deceleration is not required, slow the time to turn off the magnetic contactor.
- Note 3. When the voltage between L11 and L21 drops due to an instantaneous power failure and others, the magnetic contactor is turned off.

3. SIGNALS AND WIRING

When the converter unit receives a start command from the drive unit, CNP1-2 and L21 are shorted, and the control circuit power is supplied to the magnetic contactor. When the control circuit power is supplied, the magnetic contactor is turned on, and the main circuit power is supplied to the converter unit.

In the following cases, CNP1-2 and L21 in the converter unit are opened, and the main circuit power supply is automatically shut off.

- (a) An alarm occurred in the converter unit.
 - (b) An alarm occurred in the drive unit.
 - (c) The forced stop (EM1) of the converter unit was disabled.
 - (d) [AL. 95 STO warning] occurred in the drive unit.
- (2) When magnetic contactor drive output is disabled
- The main circuit power supply is not automatically shut off even when an alarm occurs in the converter unit or the drive unit. Therefore, configure an external circuit to shut off the main circuit power supply when detecting an alarm.

3. SIGNALS AND WIRING

3.1.2 Wiring diagram

(1) When magnetic contactor drive output is enabled (factory setting)

POINT
● The converter unit controls the magnetic contactor.
● Always connect a protection coordination cable (MR-J3CDL05M).
● Always turn on or off the control circuit power supplies of the converter unit and the drive unit simultaneously.

(a) 200 V class

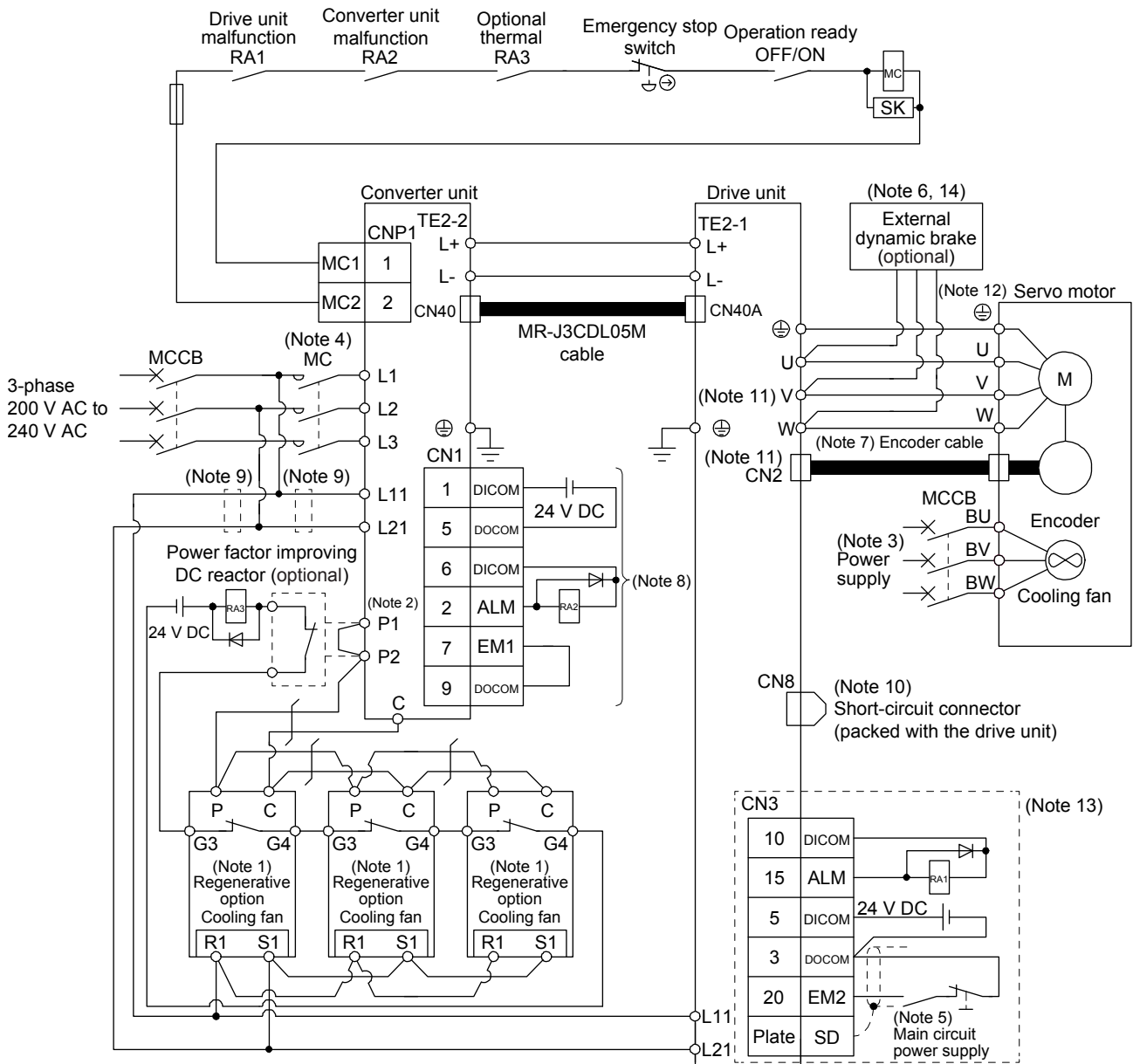

3. SIGNALS AND WIRING

- Note
1. This is for MR-RB137. For the MR-RB137, three units are used as one set (permissible regenerative power: 3900 W).
 2. P1 and P2 are connected by default. When using the power factor improving DC reactor, connect P1 and P2 after removing the short bar across them. Refer to section 9.6 for details.
 3. For specifications of the cooling fan power supply, refer to "Servo Motor Instruction Manual (Vol. 3)".
 4. Use a magnetic contactor with an operation delay time (interval between current being applied to the coil until closure of contacts) of 80 ms or less. The bus voltage decreases depending on the main circuit voltage and operation pattern, which may cause the forced stop deceleration to shift to the dynamic brake deceleration. When dynamic brake deceleration is not required, slow the time to turn off the magnetic contactor.
 5. To prevent an unexpected restart of the drive unit, configure a circuit to turn off EM2 in the drive unit when the main circuit power is turned off.
 6. Use an external dynamic brake for the drive unit. Failure to do so will cause an accident because the servo motor does not stop immediately but coasts at an alarm occurrence for which the servo motor does not decelerate to stop. Ensure the safety in the entire equipment. For alarms for which the servo motor does not decelerate to stop, refer to chapter 6. For wiring of the external dynamic brake, refer to section 9.3.
 7. For the encoder cable, use of the option cable is recommended. For selecting cables, refer to "Servo Motor Instruction Manual (Vol. 3)".
 8. This is for the sink I/O interface. For the source I/O interface, refer to section 3.6.2.
 9. Install an overcurrent protection device (molded-case circuit breaker or fuse) to protect the branch circuit. (Refer to section 9.5.)
 10. When not using the STO function, attach the short-circuit connector supplied with the drive unit.
 11. Do not connect a servo motor of the wrong axis to U, V, W, or CN2 of the drive unit. Otherwise, a malfunction may occur.
 12. For connecting servo motor power wires, refer to "Servo Motor Instruction Manual (Vol. 3)".
 13. The wiring is for MR-J4-DU_B_(-RJ). The connections to the interfaces of MR-J4-DU_(-RJ) are the same as in the case of MR-J4_(-RJ). Refer to each servo amplifier instruction manual.
 14. The external dynamic brake cannot be used for compliance with SEMI-F47 standard. Do not assign DB (Dynamic brake interlock). Failure to do so will cause the drive unit to become servo-off when an instantaneous power failure occurs.

3. SIGNALS AND WIRING

(b) 400 V class

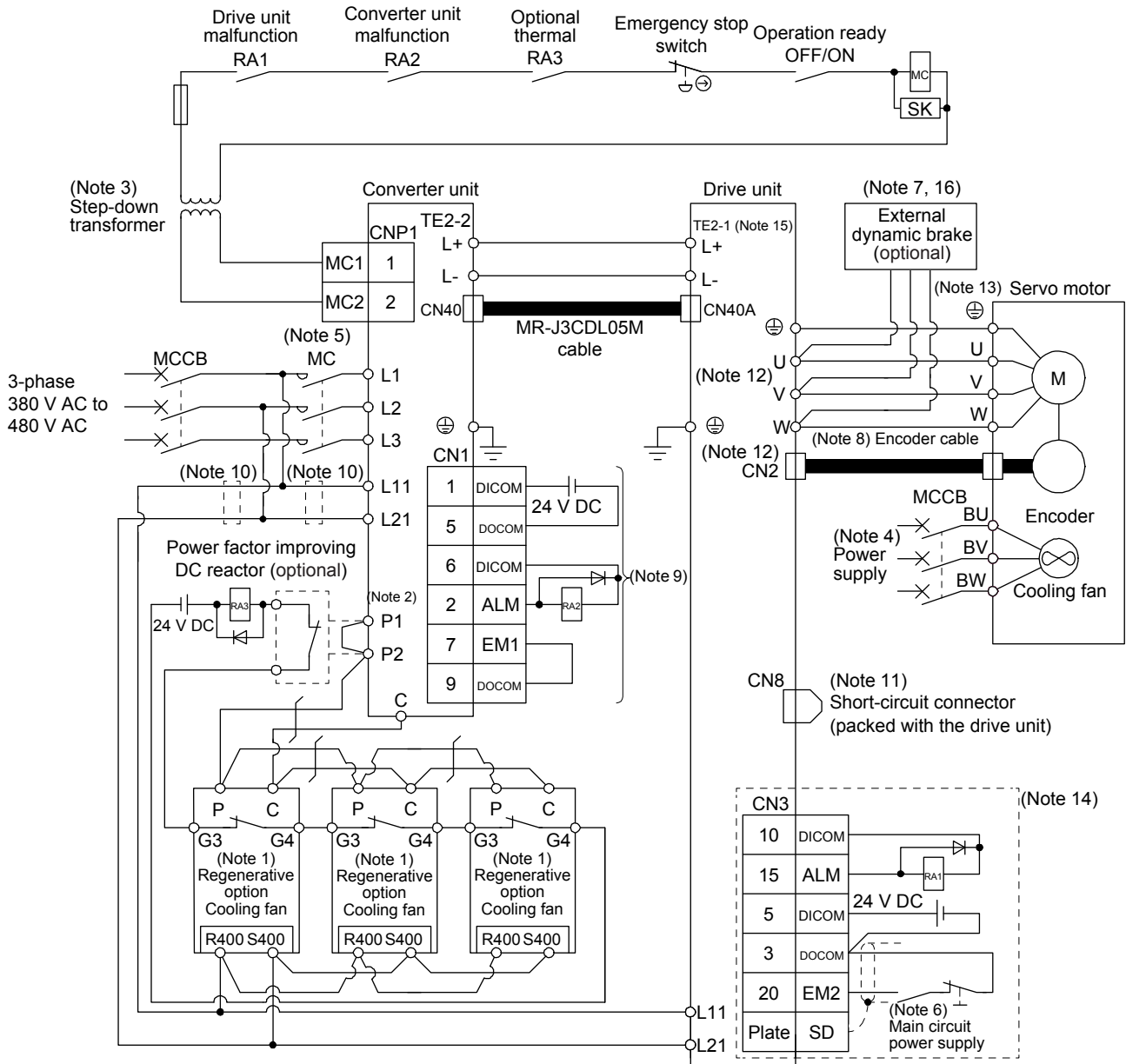

3. SIGNALS AND WIRING

- Note
1. This is for MR-RB13V-4. For the MR-RB13V-4, three units are used as one set (permissible regenerative power: 3900 W).
 2. P1 and P2 are connected by default. When using the power factor improving DC reactor, connect P1 and P2 after removing the short bar across them. Refer to section 9.6 for details.
 3. A step-down transformer is required when the coil voltage of the magnetic contactor is 200 V class.
 4. For specifications of the cooling fan power supply, refer to "Servo Motor Instruction Manual (Vol. 3)".
 5. Use a magnetic contactor with an operation delay time (interval between current being applied to the coil until closure of contacts) of 80 ms or less. The bus voltage decreases depending on the main circuit voltage and operation pattern, which may cause the forced stop deceleration to shift to the dynamic brake deceleration. When dynamic brake deceleration is not required, slow the time to turn off the magnetic contactor.
 6. To prevent an unexpected restart of the drive unit, configure a circuit to turn off EM2 in the drive unit when the main circuit power is turned off.
 7. Use an external dynamic brake for the drive unit. Failure to do so will cause an accident because the servo motor does not stop immediately but coasts at an alarm occurrence for which the servo motor does not decelerate to stop. Ensure the safety in the entire equipment. For alarms for which the servo motor does not decelerate to stop, refer to chapter 6. For wiring of the external dynamic brake, refer to section 9.3.
 8. For the encoder cable, use of the option cable is recommended. For selecting cables, refer to "Servo Motor Instruction Manual (Vol. 3)".
 9. This is for the sink I/O interface. For the source I/O interface, refer to section 3.6.2.
 10. Install an overcurrent protection device (molded-case circuit breaker or fuse) to protect the branch circuit. (Refer to section 9.5.)
 11. When not using the STO function, attach the short-circuit connector supplied with the drive unit.
 12. Do not connect the servo motor of a wrong axis to U, V, W, or CN2 of the drive unit. Otherwise, a malfunction may occur.
 13. For connecting servo motor power wires, refer to "Servo Motor Instruction Manual (Vol. 3)".
 14. The wiring is for MR-J4-DU_B_(-RJ). The connections to the interfaces of MR-J4-DU_(-RJ) are the same as in the case of MR-J4_(-RJ). Refer to each servo amplifier instruction manual.
 15. For the MR-J4-DU30K_4(-RJ) and MR-J4-DU37K_4(-RJ), the terminal block is TE2.
 16. The external dynamic brake cannot be used for compliance with SEMI-F47 standard. Do not assign DB (Dynamic brake interlock). Failure to do so will cause the drive unit to become servo-off when an instantaneous power failure occurs.

3. SIGNALS AND WIRING

(2) When magnetic contactor drive output is disabled

POINT
<ul style="list-style-type: none"> ● Always connect a protection coordination cable (MR-J3CDL05M). ● Always turn on or off the control circuit power supplies of the converter unit and the drive unit simultaneously.

(a) 200 V class

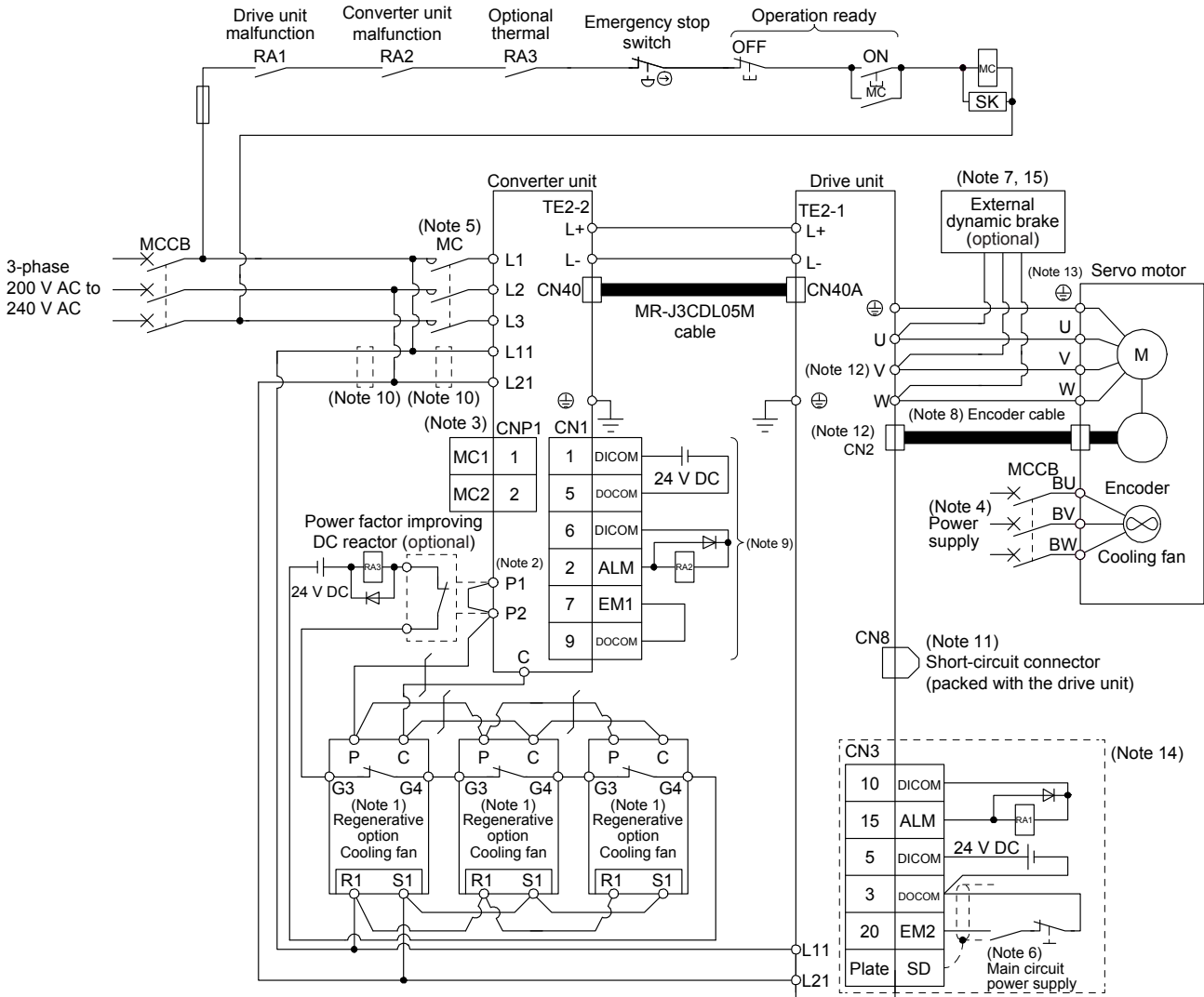

3. SIGNALS AND WIRING

- Note
1. This is for MR-RB137. For the MR-RB137, three units are used as one set (permissible regenerative power: 3900 W).
 2. P1 and P2 are connected by default. When using the power factor improving DC reactor, connect P1 and P2 after removing the short bar across them. Refer to section 9.6 for details.
 3. Always connect the magnetic contactor wiring connector to CNP1 of the converter unit. If the connector is not connected, an electric shock may occur.
 4. For specifications of the cooling fan power supply, refer to "Servo Motor Instruction Manual (Vol. 3)".
 5. Use a magnetic contactor with an operation delay time (interval between current being applied to the coil until closure of contacts) of 80 ms or less. The bus voltage decreases depending on the main circuit voltage and operation pattern, which may cause the forced stop deceleration to shift to the dynamic brake deceleration. When dynamic brake deceleration is not required, slow the time to turn off the magnetic contactor.
 6. To prevent an unexpected restart of the drive unit, configure a circuit to turn off EM2 in the drive unit when the main circuit power is turned off.
 7. Use an external dynamic brake for the drive unit. Failure to do so will cause an accident because the servo motor does not stop immediately but coasts at an alarm occurrence for which the servo motor does not decelerate to stop. Ensure the safety in the entire equipment. For alarms for which the servo motor does not decelerate to stop, refer to chapter 6. For wiring of the external dynamic brake, refer to section 9.3.
 8. For the encoder cable, use of the option cable is recommended. For selecting cables, refer to "Servo Motor Instruction Manual (Vol. 3)".
 9. This is for the sink I/O interface. For the source I/O interface, refer to section 3.6.2.
 10. Install an overcurrent protection device (molded-case circuit breaker or fuse) to protect the branch circuit. (Refer to section 9.5.)
 11. When not using the STO function, attach the short-circuit connector supplied with the drive unit.
 12. Do not connect the servo motor of a wrong axis to U, V, W, or CN2 of the drive unit. Otherwise, a malfunction may occur.
 13. For connecting servo motor power wires, refer to "Servo Motor Instruction Manual (Vol. 3)".
 14. The wiring is for MR-J4-DU_B_(-RJ). The connections to the interfaces of MR-J4-DU_(-RJ) are the same as in the case of MR-J4_(-RJ). Refer to each servo amplifier instruction manual.
 15. The external dynamic brake cannot be used for compliance with SEMI-F47 standard. Do not assign DB (Dynamic brake interlock). Failure to do so will cause the drive unit to become servo-off when an instantaneous power failure occurs.

3. SIGNALS AND WIRING

(b) 400 V class

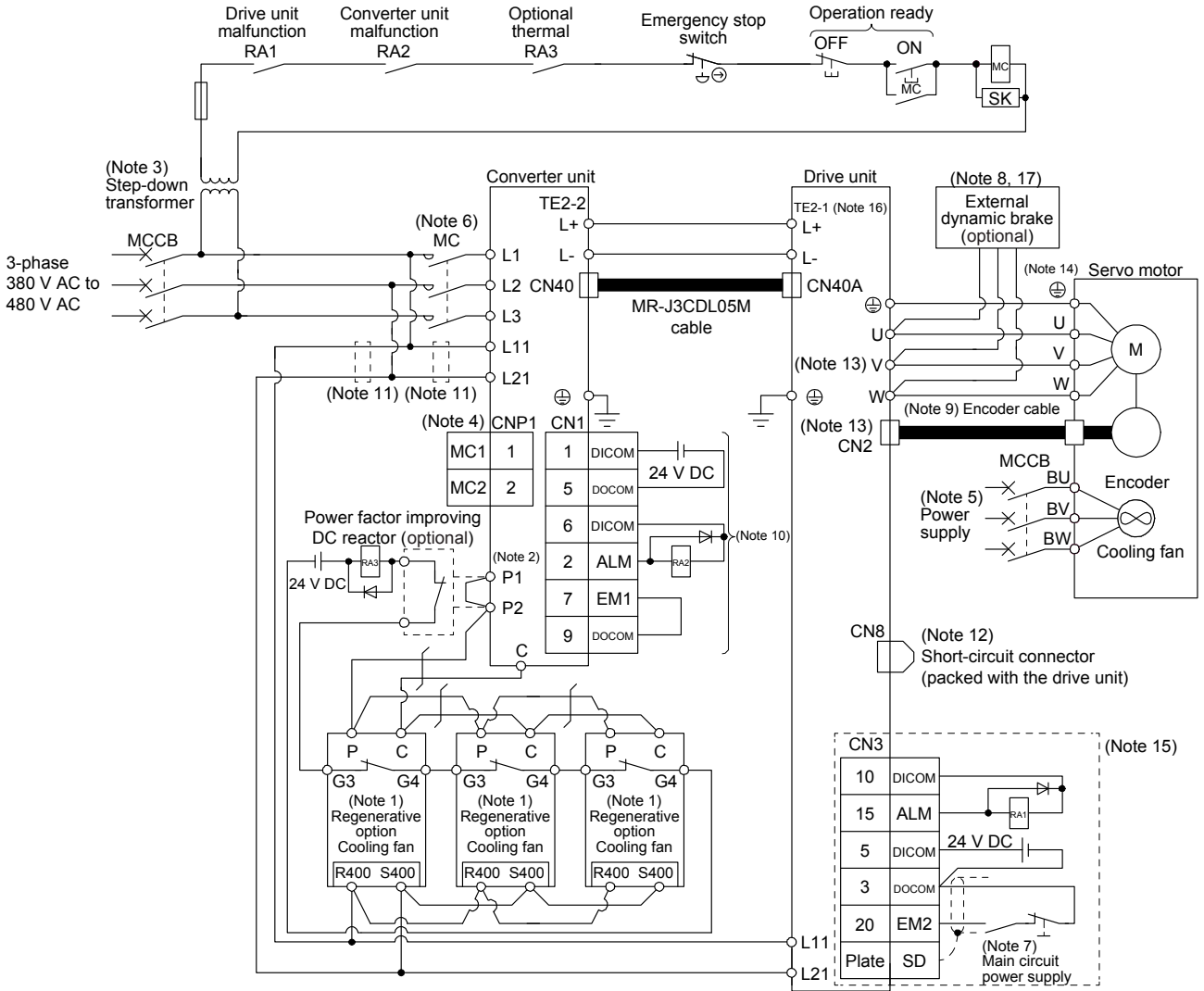

3. SIGNALS AND WIRING

- Note
1. This is for MR-RB13V-4. For the MR-RB13V-4, three units are used as one set (permissible regenerative power: 3900 W).
 2. P1 and P2 are connected by default. When using the power factor improving DC reactor, connect P1 and P2 after removing the short bar across them. Refer to section 9.6 for details.
 3. A step-down transformer is required when the coil voltage of the magnetic contactor is 200 V class.
 4. Always connect the magnetic contactor wiring connector to CNP1 of the converter unit. If the connector is not connected, an electric shock may occur.
 5. For specifications of the cooling fan power supply, refer to "Servo Motor Instruction Manual (Vol. 3)".
 6. Use a magnetic contactor with an operation delay time (interval between current being applied to the coil until closure of contacts) of 80 ms or less. The bus voltage decreases depending on the main circuit voltage and operation pattern, which may cause the forced stop deceleration to shift to the dynamic brake deceleration. When dynamic brake deceleration is not required, slow the time to turn off the magnetic contactor.
 7. To prevent an unexpected restart of the drive unit, configure a circuit to turn off EM2 in the drive unit when the main circuit power is turned off.
 8. Use an external dynamic brake for the drive unit. Failure to do so will cause an accident because the servo motor does not stop immediately but coasts at an alarm occurrence for which the servo motor does not decelerate to stop. Ensure the safety in the entire equipment. For alarms for which the servo motor does not decelerate to stop, refer to chapter 6. For wiring of the external dynamic brake, refer to section 9.3.
 9. For the encoder cable, use of the option cable is recommended. For selecting cables, refer to "Servo Motor Instruction Manual (Vol. 3)".
 10. This is for the sink I/O interface. For the source I/O interface, refer to section 3.6.2.
 11. Install an overcurrent protection device (molded-case circuit breaker or fuse) to protect the branch circuit. (Refer to section 9.5.)
 12. When not using the STO function, attach the short-circuit connector supplied with the drive unit.
 13. Do not connect the servo motor of a wrong axis to U, V, W, or CN2 of the drive unit. Otherwise, a malfunction may occur.
 14. For connecting servo motor power wires, refer to "Servo Motor Instruction Manual (Vol. 3)".
 15. The wiring is for MR-J4-DU_B_(-RJ). The connections to the interfaces of MR-J4-DU_(-RJ) are the same as in the case of MR-J4_(-RJ). Refer to each servo amplifier instruction manual.
 16. For the MR-J4-DU30K_4(-RJ) and MR-J4-DU37K_4(-RJ), the terminal block is TE2.
 17. The external dynamic brake cannot be used for compliance with SEMI-F47 standard. Do not assign DB (Dynamic brake interlock). Failure to do so will cause the drive unit to become servo-off when an instantaneous power failure occurs.

3. SIGNALS AND WIRING

3.1.3 How to use the bus bars

Make sure to use the supplied bus bars and connect the L+ and L- of the drive unit to those of the converter unit as shown below. Never use bus bars other than the ones supplied with the drive unit. Both the units are shown with the terminal cover open.

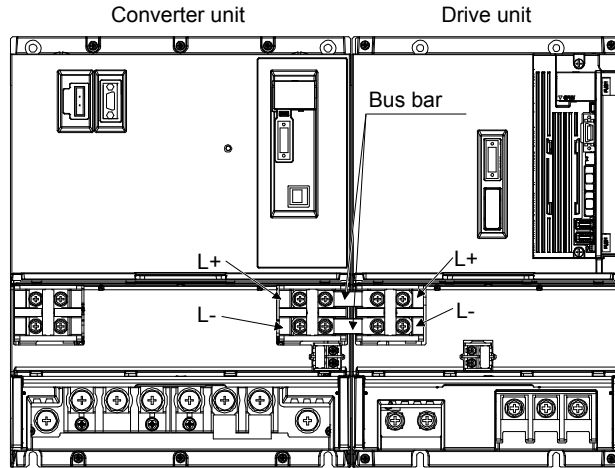

3. SIGNALS AND WIRING

3.2 Explanation of power supply system

3.2.1 Signal explanations

POINT
● For the layout of the terminal block, refer to chapter 7 DIMENSIONS.

(1) Converter unit

Connection target (application)	Symbol	(Note) Terminal block	Description	
			MR-CR55K	MR-CR55K4
Main circuit power supply	L1/L2/L3	TE1-1	Supply 3-phase 200 V AC to 240 V AC, 50 Hz/60 Hz power to L1, L2, and L3.	Supply 3-phase 380 V AC to 480 V AC, 50 Hz/60 Hz power to L1, L2, and L3.
Control circuit power supply	L11/L21	TE3	Supply 1-phase 200 V AC to 240 V AC, 50 Hz/60 Hz power to L11 and L21.	Supply 1-phase 380 V AC to 480 V AC, 50 Hz/60 Hz power to L11 and L21.
Power factor improving DC reactor	P1/P2	TE1-2	When using the power factor improving DC reactor, connect P1 and P2 after removing the short bar across them.	
Regenerative option	P2/C	TE1-2	Connect the regenerative option between P2 and C.	
Brake unit	L+/L-	TE2-1	When using a brake unit, connect it to this terminal. Do not connect anything other than the brake unit.	
Drive unit	L+/L-	TE2-2	Connect the L+ and L- of the drive unit to this terminal. Use the bus bars supplied with the drive unit to connect.	
Protective earth (PE)	⊕	PE	Connect the protective earth (PE) of the cabinet to this terminal.	

Note. The permissible tension applied to any of the terminal blocks TE1-1, TE1-2, TE2-1, TE2-2 is 350 N.

(2) Drive unit

Connection target (application)	Symbol	(Note 1) Terminal block	Description	
			MR-J4-DU30K_(-RJ)/ MR-J4-DU37K_(-RJ)	MR-J4-DU30K_4(-RJ) to MR-J4-DU55K_4(-RJ)
Control circuit power supply	L11/L21	TE3	Supply 1-phase 200 V AC to 240 V AC, 50 Hz/60 Hz power to L11 and L21.	Supply 1-phase 380 V AC to 480 V AC, 50 Hz/60 Hz power to L11 and L21.
Converter unit	L+/L-	TE2-1 (TE2) (Note 2)	Connect the L+ and L- of the converter unit to this terminal. Use the bus bars supplied with the drive unit to connect.	
Servo motor power output	U/V/W	TE1	Connect the drive unit power outputs (U, V, and W) to the servo motor power inputs (U, V, and W) directly. Do not let a magnetic contactor, etc. intervene. Otherwise, it may cause a malfunction.	
Protective earth (PE)	⊕	PE	Connect the grounding terminal of the servo motor and the protective earth (PE) of the cabinet to this terminal.	

Note 1. The permissible tension applied to any of the terminal blocks TE1, TE2-1 (TE2) is 350 N.
 2. Explanations in parentheses are for MR-J4-DU30K_4(-RJ) and MR-J4-DU7K_4(-RJ).

3. SIGNALS AND WIRING

3.2.2 Power-on sequence

(1) MR-J4-DU_A_(-RJ)

(a) Power-on procedure

- 1) Always use a magnetic contactor for the main circuit power supply wiring (L1, L2, and L3) as shown in above section 3.1.2. Configure an external sequence to switch off the magnetic contactor as soon as an alarm occurs.
- 2) When enabling magnetic contactor drive output, turn on the control circuit power supplies (L11/L21) of the converter unit and the drive unit simultaneously. The main circuit power supply is automatically turned on after the converter unit and drive unit are started. When using an external sequence to control the magnetic contactor, turn on the control circuit power supplies (L11/ L21) of the converter unit and drive unit simultaneously with the main circuit power supply or before turning on the main circuit power supply. If the main circuit power supply is not on, the display shows the corresponding warning. However, by switching on the main circuit power supply, the warning disappears and the drive unit will operate properly.

(b) Timing chart

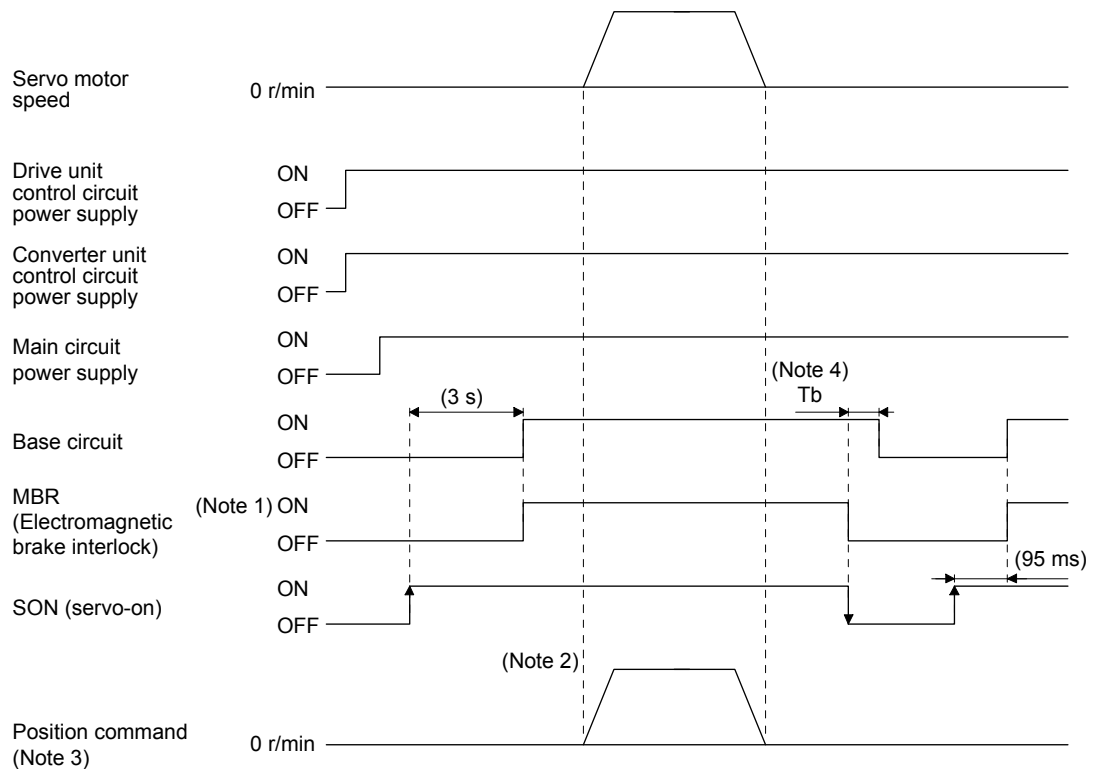

- Note 1. When setting up an electromagnetic brake at customer's side, make up a sequence which will operate the electromagnetic brake as follow using MBR (Electromagnetic brake interlock).
 ON: Electromagnetic brake is not activated.
 OFF: Electromagnetic brake is activated.
- Note 2. Give a position command after the external electromagnetic brake is released.
- Note 3. This is in position control mode.
- Note 4. In [Pr. PC16 Electromagnetic brake sequence output], set a delay time (T_b) from MBR (Electromagnetic brake interlock) off to base circuit shut-off at a servo-off.

3. SIGNALS AND WIRING

(2) MR-J4-DU_B_(-RJ)

(a) Power-on procedure

- 1) Always use a magnetic contactor for the main circuit power supply wiring (L1, L2, and L3) as shown in above section 3.1.2. Configure an external sequence to switch off the magnetic contactor as soon as an alarm occurs.
- 2) Turn on the control circuit power supplies (L11/L21) of the converter unit and drive unit simultaneously with the main circuit power supply or before turning on the main circuit power supply. If the main circuit power supply is not on, the display shows the corresponding warning. However, by switching on the main circuit power supply, the warning disappears and the drive unit will operate properly.

(b) Timing chart

- 1) When magnetic contactor drive output is enabled and the status remains at ready-on
The main circuit power is not shut off with servo-off.

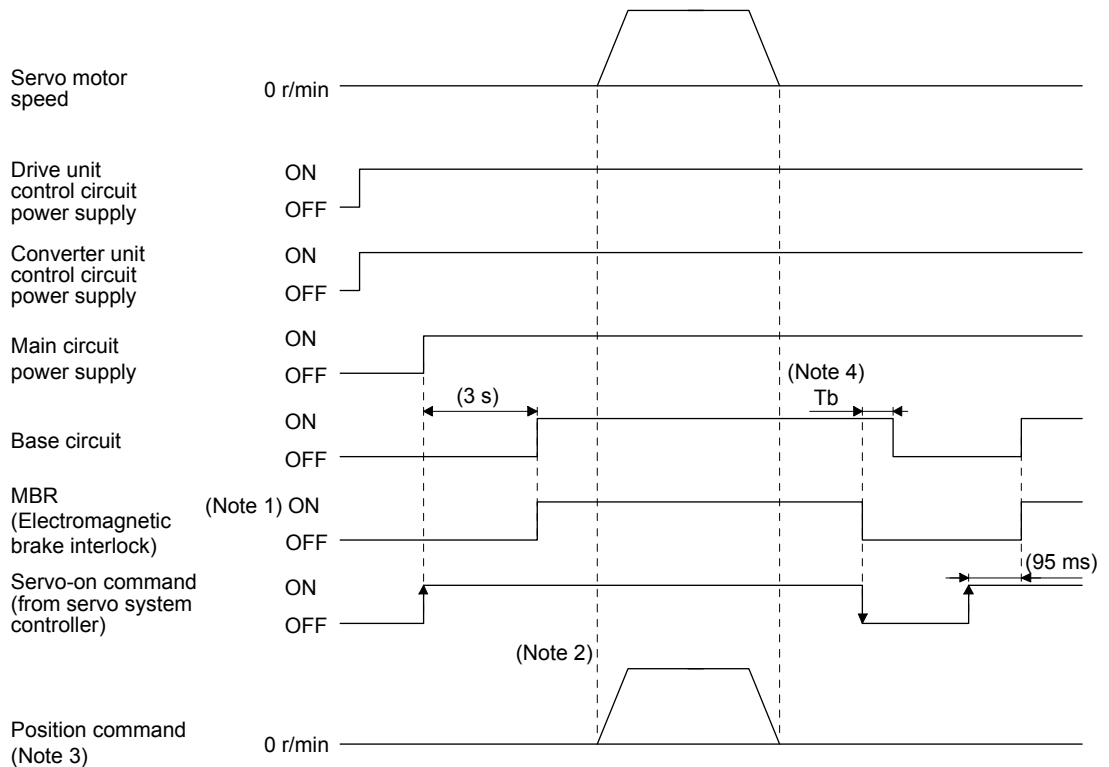

- Note 1. When setting up an electromagnetic brake at customer's side, make up a sequence which will operate the electromagnetic brake as follow using MBR (Electromagnetic brake interlock).
ON: Electromagnetic brake is not activated.
OFF: Electromagnetic brake is activated.
2. Give a position command after the external electromagnetic brake is released.
 3. This is in position control mode.
 4. In [Pr. PC02 Electromagnetic brake sequence output], set a delay time (T_b) from MBR (Electromagnetic brake interlock) off to base circuit shut-off at a servo-off.

3. SIGNALS AND WIRING

- 2) When magnetic contactor drive output is enabled and the status returns to ready-off
 The magnetic contactor of the converter unit is turned off with servo-off, and the main circuit power supply is shut off.

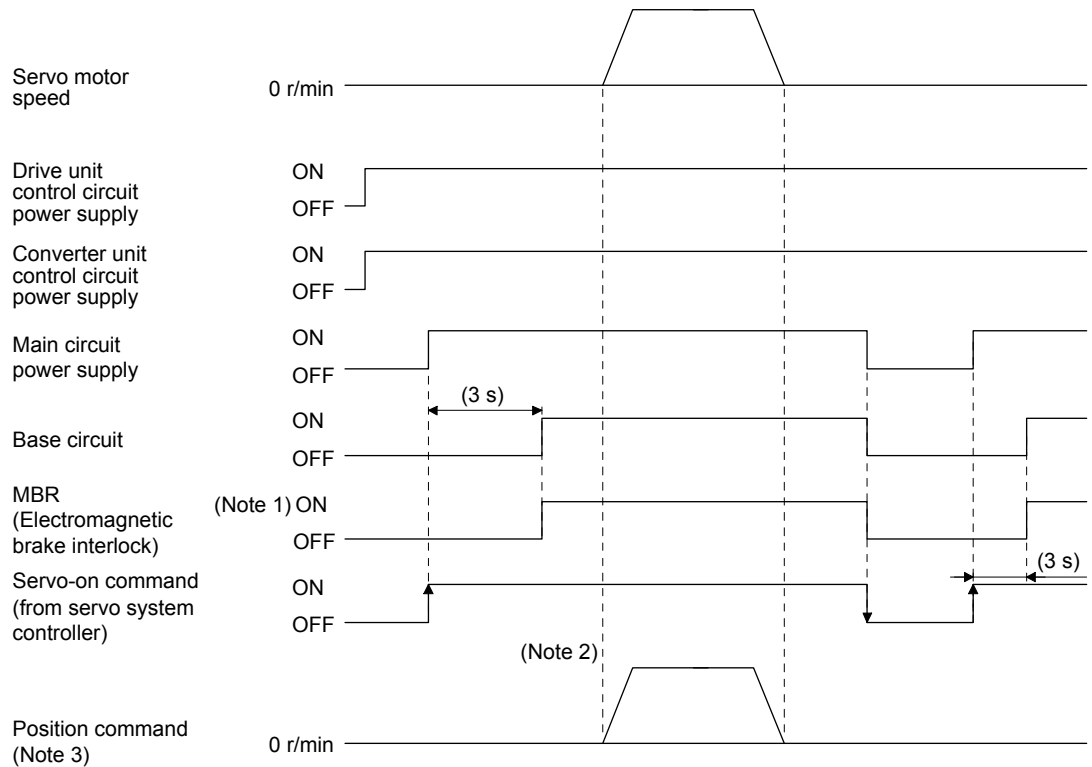

- Note 1. When setting up an electromagnetic brake at customer's side, make up a sequence which will operate the electromagnetic brake as follow using MBR (Electromagnetic brake interlock).
 ON: Electromagnetic brake is not activated.
 OFF: Electromagnetic brake is activated.
2. Give a position command after the external electromagnetic brake is released.
3. This is in position control mode.

3. SIGNALS AND WIRING

3) When magnetic contactor drive output is disabled

When an alarm occurs, turn off the magnetic contactor using the external sequence, and shut off the main circuit power supply.

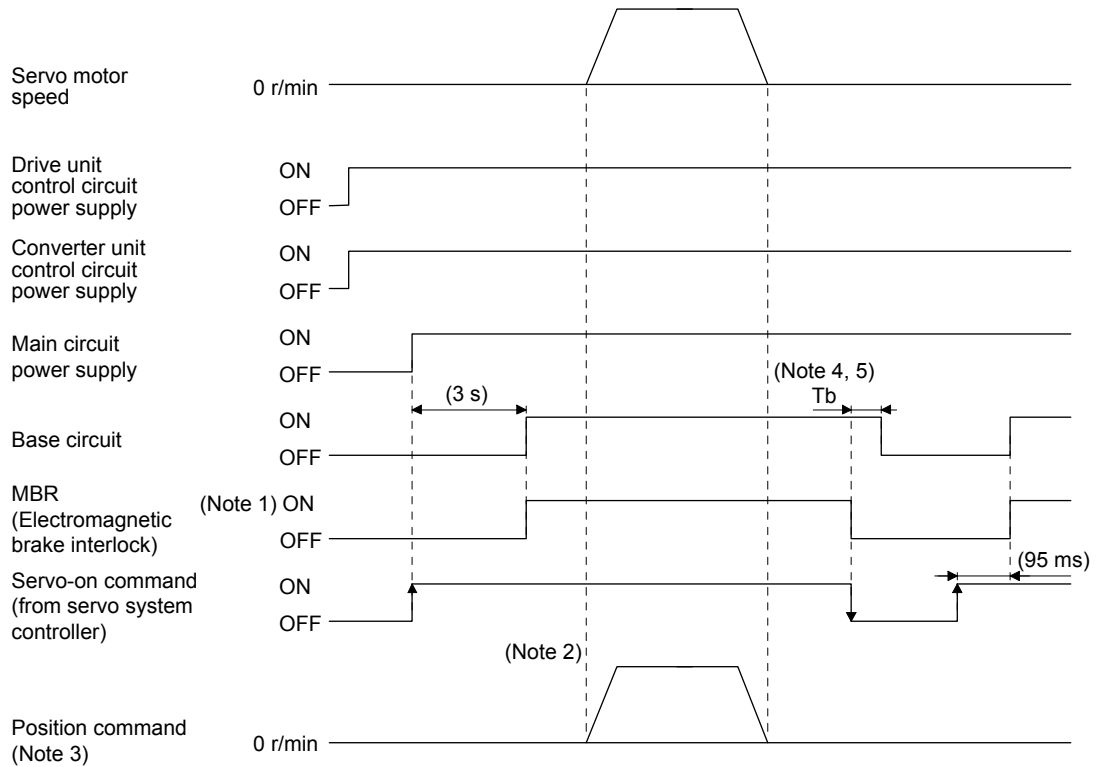

- Note 1. When setting up an electromagnetic brake at customer's side, make up a sequence which will operate the electromagnetic brake as follow using MBR (Electromagnetic brake interlock).
 ON: Electromagnetic brake is not activated.
 OFF: Electromagnetic brake is activated.
2. Give a position command after the external electromagnetic brake is released.
3. This is in position control mode.
4. In [Pr. PC02 Electromagnetic brake sequence output], set a delay time (T_b) from MBR (Electromagnetic brake interlock) off to base circuit shut-off at a servo-off.
5. The base circuit remains ready-on status at servo-off. When the status is ready-off, the base circuit and the servo-on command turn off at the same time. ($T_b = 0$)

3. SIGNALS AND WIRING

3.3 Connectors and pin assignment

POINT

● The pin assignment of the connectors is as viewed from the cable connector wiring section.

3.3.1 Converter unit

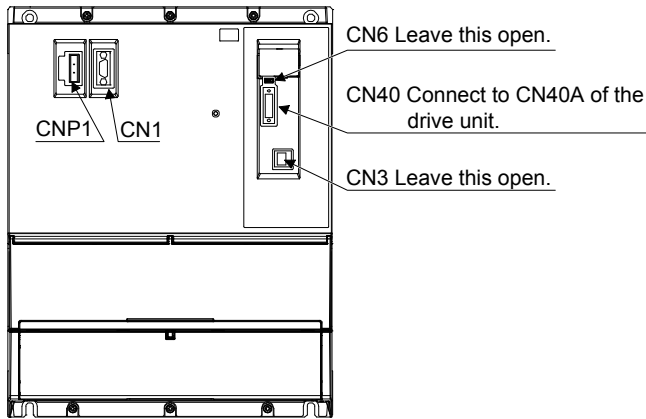

CN1 (Digital I/O connector)
 Model: 17JE-23090-02(D8A)K11-CG (D-sub 9 pin or equivalent)
 (DDK)

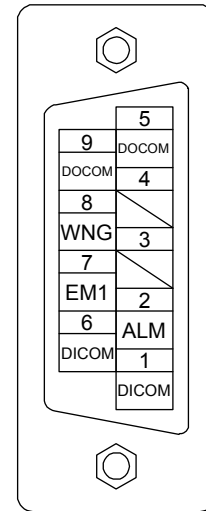

CNP1 (Magnetic contactor wiring connector)
 Model: GFKC 2,5/2-STF-7,62
 (Phoenix Contact)

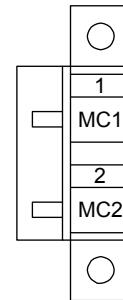

3. SIGNALS AND WIRING

3.3.2 Drive unit

(1) MR-J4-DU_A_(-RJ)

The following shows the front view of MR-J4-DU30KA4-RJ and MR-J4-DU37KA4-RJ drive units. For other views of drive units, connector arrangements, and details, refer to "MR-J4-_A_(-RJ) Servo Amplifier Instruction Manual".

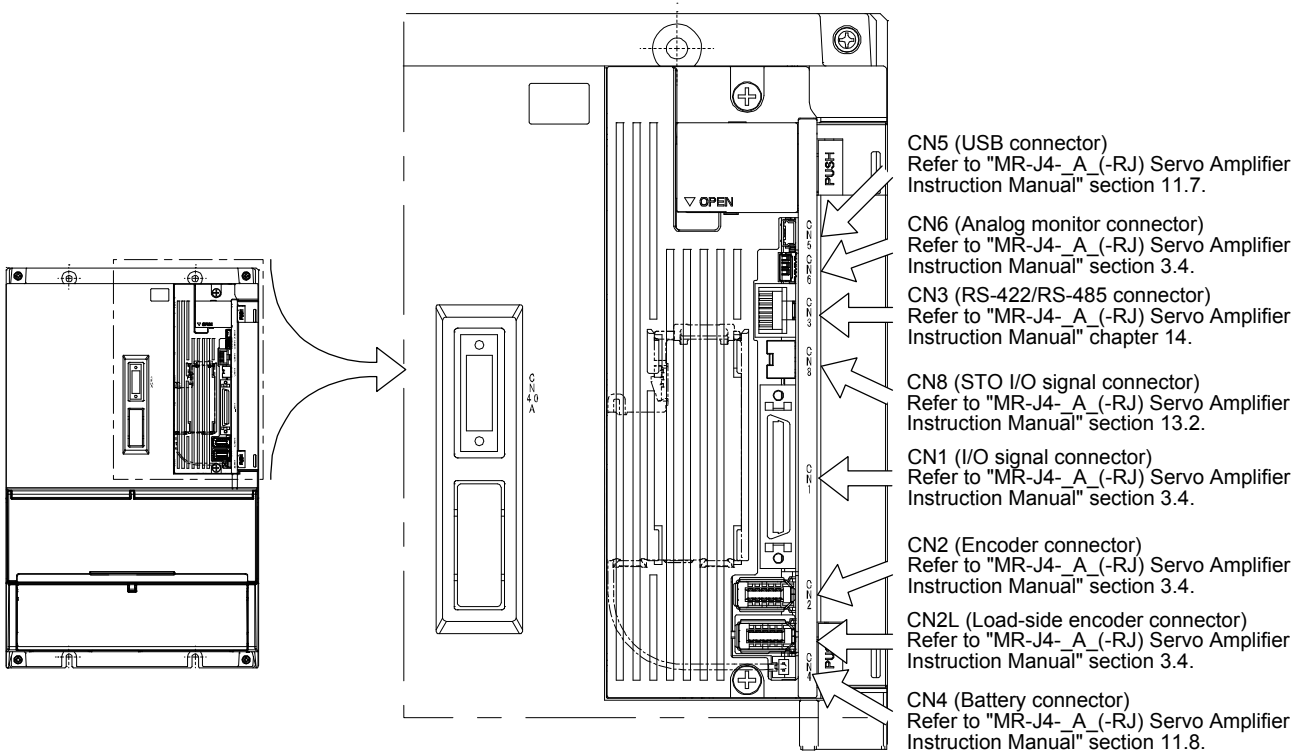

The frames of the CN2 and CN3 connectors are connected to the protective earth terminal in the drive unit.

3. SIGNALS AND WIRING

(2) MR-J4-DU_B_(-RJ)

The following shows the front view of MR-J4-DU30KB4-RJ and MR-J4-DU37KB4-RJ drive units. For other views of drive units, connector arrangements, and details, refer to "MR-J4-_B_(-RJ) Servo Amplifier Instruction Manual".

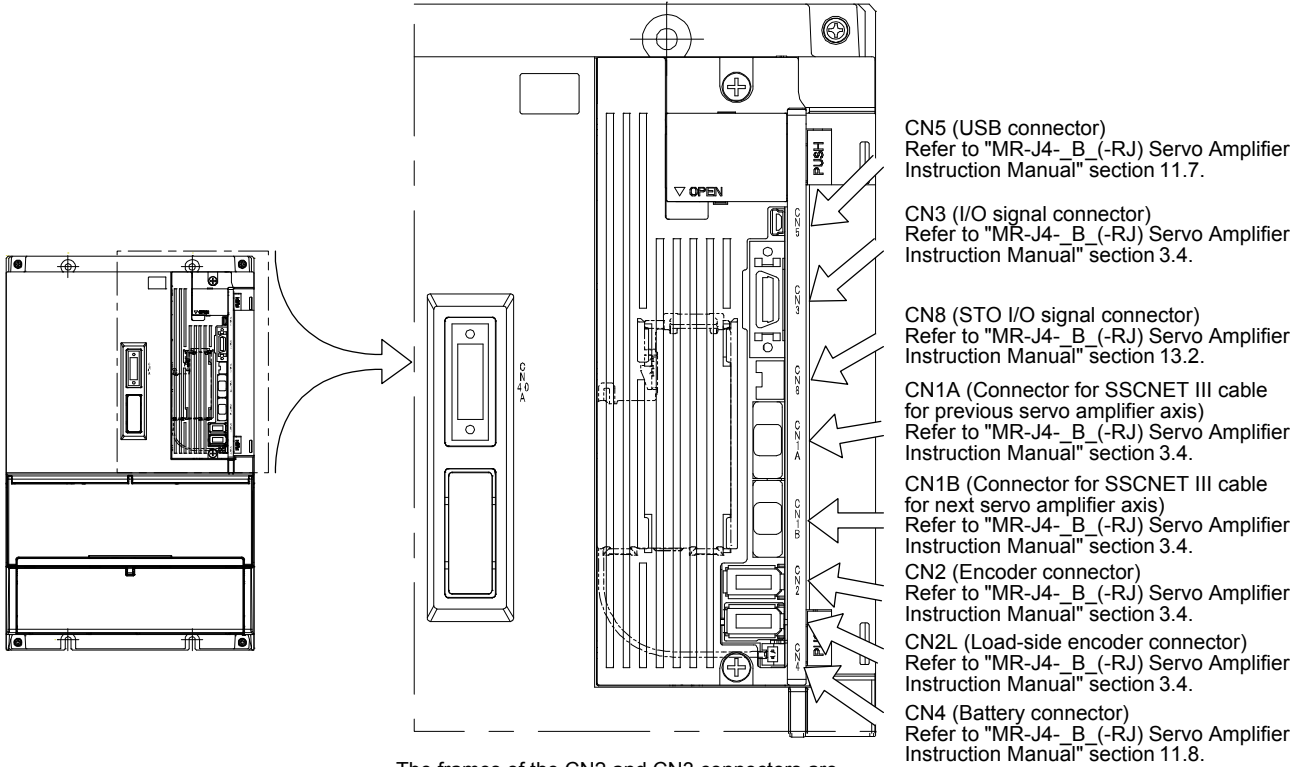

The frames of the CN2 and CN3 connectors are connected to the protective earth terminal in the drive unit.

3. SIGNALS AND WIRING

3.4 Signal (device) explanations

Signals (devices) of MR-J4-DU_(-RJ) are the same as those of MR-J4_(-RJ). For the MR-J4-DU_A_(-RJ), refer to section 3.5 of "MR-J4-A_(-RJ) Servo Amplifier Instruction Manual". For the MR-J4-DU_B_(-RJ), refer to section 3.5 of "MR-J4-B_(-RJ) Servo Amplifier Instruction Manual".

The following table lists the converter unit signals (devices).

For the I/O interfaces (symbols in I/O division column in the table), refer to section 3.6.1.

Signal (device)	Symbol	Connector pin No.	Function and application	I/O division
Digital I/F power supply input	DICOM	CN1-1 CN1-6	Input 24 V DC (24 V DC \pm 10% 150 mA) for I/O interface. The power supply capacity changes depending on the number of I/O interface points to be used. For sink interface, connect + of 24 V DC external power supply. For source interface, connect - of 24 V DC external power supply.	
Forced stop	EM1	CN1-7	When MR-CR55K is used with MR-J4-DU_(-RJ), EM1 is not used. Connect between EM1 and Docom externally. Turn EM1 off to bring the converter unit to a forced stop state. In this state, the magnetic connector is turned off, [AL. E9 Main circuit off warning] occurs in the drive unit, and the servo-on turns off. When the converter unit is in the forced stop state, turning EM1 on resets the state.	DI
Malfunction	ALM	CN1-2	ALM turns off when power is switched off or the protective circuit is activated. When no alarm occurs, ALM turns on 1.5 s after power-on.	DO
Warning	WNG	CN1-8	When warning has occurred, WNG turns on.	DO
Digital I/F common	DOCOM	CN1-5 CN1-9	Common terminal for the ALM and WNG output signals of the converter unit. This is separated from LG. Pins are connected internally. For sink interface, connect - of 24 V DC external power supply. For source interface, connect + of 24 V DC external power supply.	
Magnetic contactor drive output	MC1	CNP1-1	Connect it to the coil of the magnetic contactor. Always supplies the control circuit power since it is conducted with L11 in the converter unit. <div style="border: 1px solid black; padding: 5px; display: inline-block;">  WARNING ● Always connect the magnetic contactor wiring connector to CNP1 of the converter unit. Disconnected state may cause an electric shock. </div>	
	MC2	CNP1-2	Connect it to the coil of the magnetic contactor. When the converter unit receives a start command from the drive unit, CNP1-2 and L21 are shorted, and the control circuit power is supplied to the magnetic contactor. Set "___0" in [Pr. PA02] when controlling the magnetic contactor without magnetic contactor control connector (CNP1). (Refer to section 3.1.1.)	

3. SIGNALS AND WIRING

3.5 Alarm occurrence timing chart



CAUTION

- When an alarm has occurred, remove its cause, make sure that the operation signal is not being input, ensure safety, and reset the alarm before restarting operation.
- As soon as an alarm occurs, make the Servo-off status and interrupt the main circuit power.

3.5.1 MR-J4-DU_A_(-RJ)

(1) When magnetic contactor drive output is enabled

(a) Converter unit

When an alarm occurs in the converter unit, the magnetic contactor is turned off and the main circuit magnetic contactor is shut off. The drive unit in operation stops. To deactivate the alarm, cycle the control circuit power. However, the alarm cannot be deactivated unless its cause is removed.

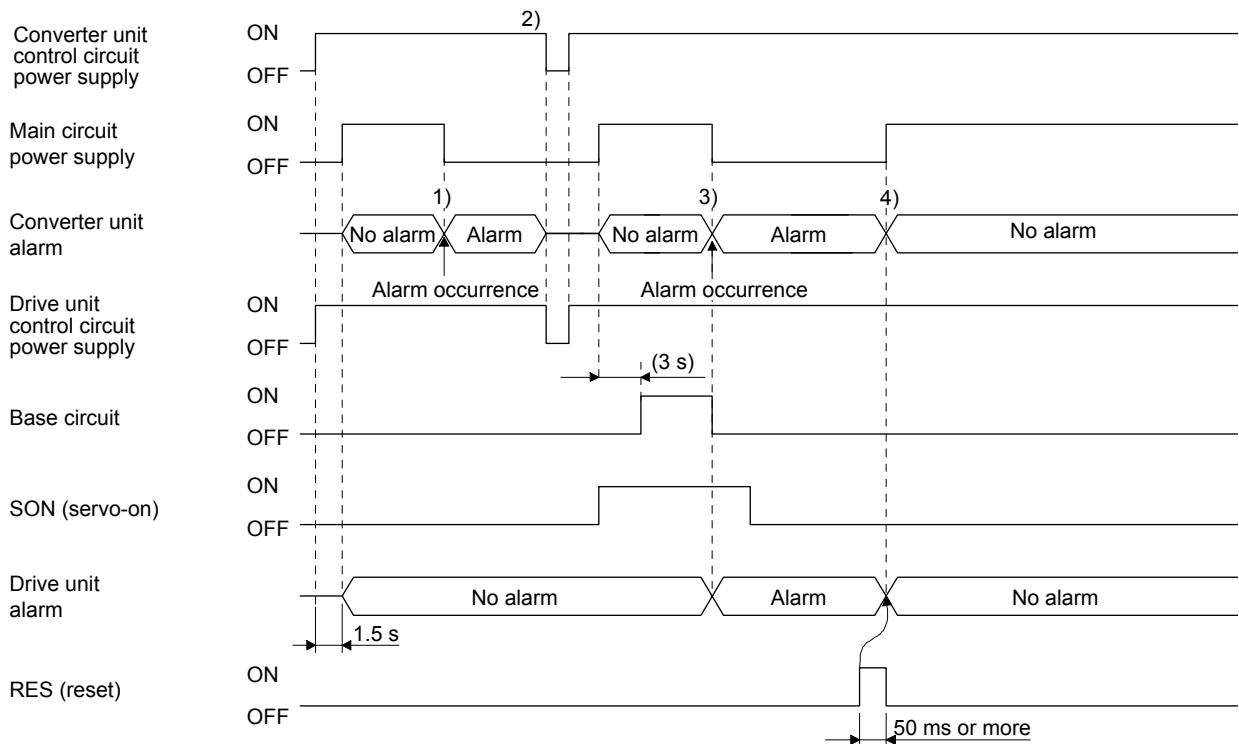

- (1) in figure) When the drive unit is at servo-off, even if an alarm occurs in the converter, the drive unit does not detect the alarm.
- (2) in figure) To deactivate the alarm of the converter unit, cycle the power of the converter unit.
- (3) in figure) If an alarm occurs in the converter unit when the drive unit is at servo-on, the alarm also occurs in the drive unit and the drive unit becomes servo-off.
- (4) in figure) When alarms occur in both the converter unit and the drive unit, cancelling the alarm in the drive unit will also cancel the alarm in the converter unit.

3. SIGNALS AND WIRING

(b) Drive unit

When an alarm occurs in the drive unit, the base circuit is shut off and the servo motor coasts. When an external dynamic brake (option) is used, the external dynamic brake is activated to stop the servo motor. To deactivate an alarm, cycle the control circuit power, push the "SET" button in the current alarm window, or cycle the RES (Reset). However, the alarm cannot be deactivated unless its cause is removed.

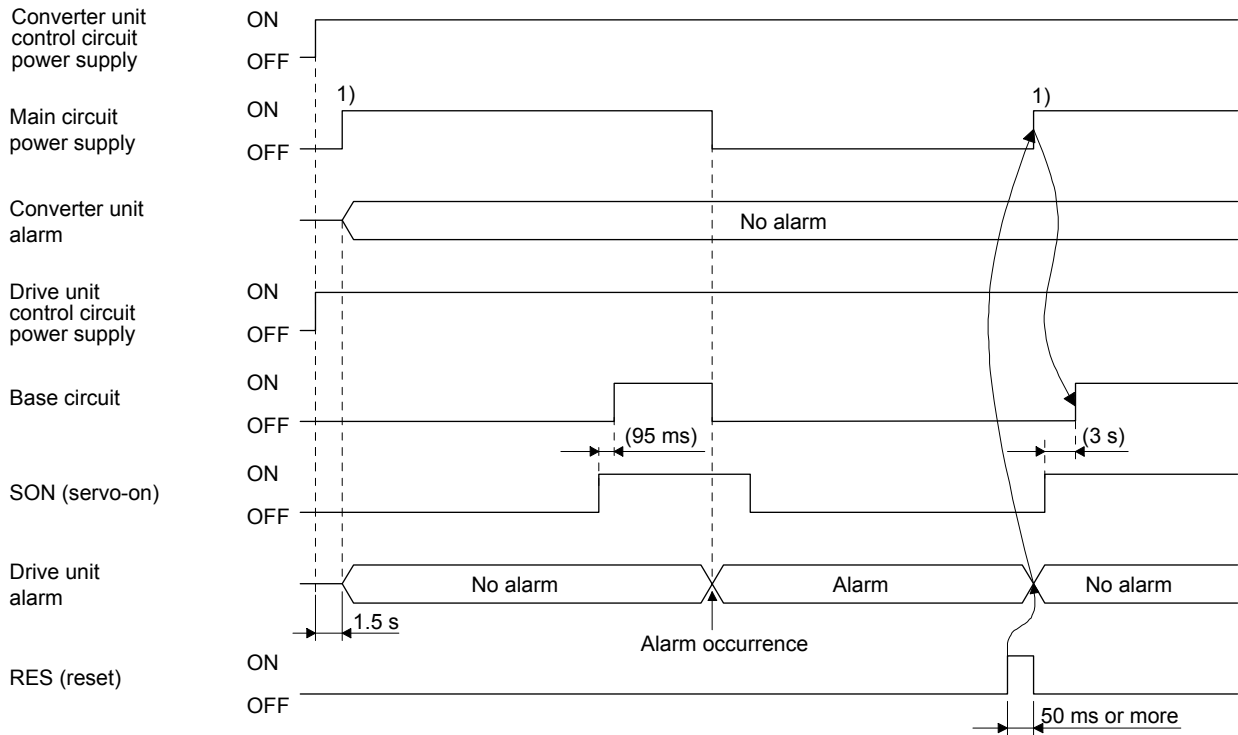

(1) in figure) After the start-up of the drive unit is completed, the main circuit power is supplied while the drive unit and the converter unit have no alarm.

3. SIGNALS AND WIRING

(2) When magnetic contactor drive output is disabled

(a) Converter unit

When an alarm occurs in the converter unit, the converter unit turns into servo-off, but the main circuit power supply is not shut off. Therefore, shut off the main circuit power supply using the external sequence. Cancel the alarm in the converter unit. If an alarm also occurs in the drive unit, cancel the alarm in the drive unit as well. Then, turn on the RES (Reset) to resume the operation.

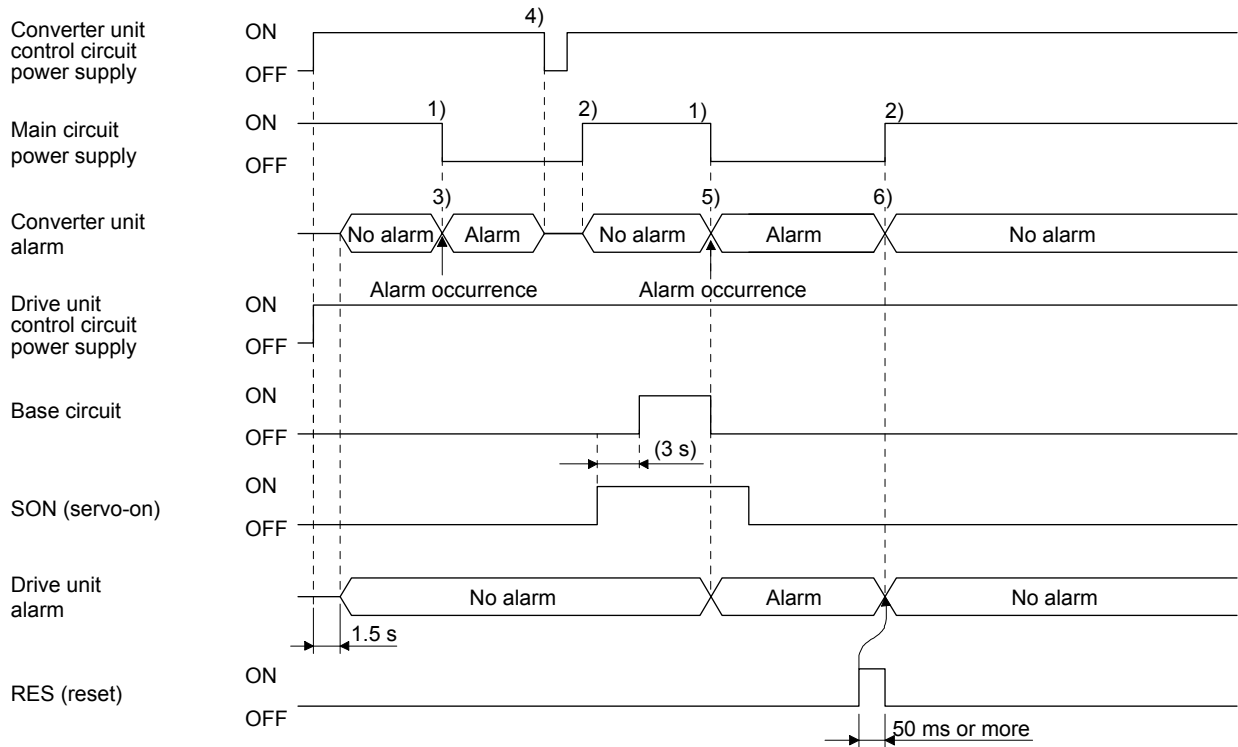

- (1) in figure) When an alarm occurs in the converter unit, shut off the main circuit power supply using the external sequence.
- (2) in figure) Turn on the main circuit power supply while an alarm in the drive unit is cancelled.
- (3) in figure) When the drive unit is at servo-off, even if an alarm occurs in the converter, the drive unit does not detect the alarm.
- (4) in figure) To deactivate the alarm of the converter unit, cycle the power of the converter unit.
- (5) in figure) If an alarm occurs in the converter unit when the drive unit is at servo-on, the alarm also occurs in the drive unit and the drive unit becomes servo-off.
- (6) in figure) When alarms occur in both the converter unit and the drive unit, cancelling the alarm in the drive unit will also cancel the alarm in the converter unit.

3. SIGNALS AND WIRING

(b) Drive unit

When an alarm occurs in the drive unit, the drive unit turns into the servo-off, but the main circuit power supply is not shut off. Therefore, shut off the main circuit power supply using the external sequence. After cancelling the alarm in the drive unit, turn on the RES (Reset) to resume the operation.

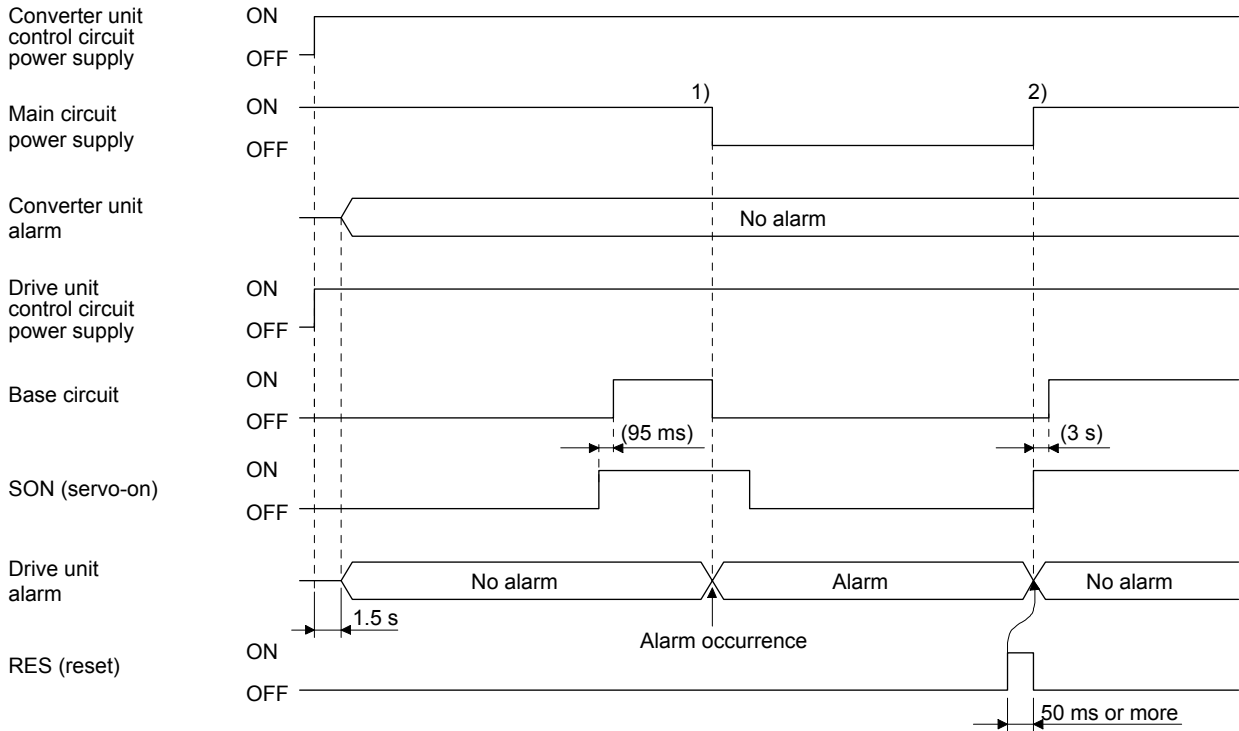

(1) in figure) When an alarm occurs in the drive unit, shut off the main circuit power supply using the external sequence.

(2) in figure) Turn on the main circuit power supply while an alarm in the drive unit is cancelled.

3. SIGNALS AND WIRING

3.5.2 MR-J4-DU_B_(-RJ)

(1) When magnetic contactor drive output is enabled

(a) Converter unit

When an alarm occurs in the converter unit, the magnetic contactor is turned off and the main circuit magnetic contactor is shut off. The drive unit in operation stops. To deactivate the alarm, cycle the control circuit power or request the operation from the driver unit. However, the alarm cannot be deactivated unless its cause is removed.

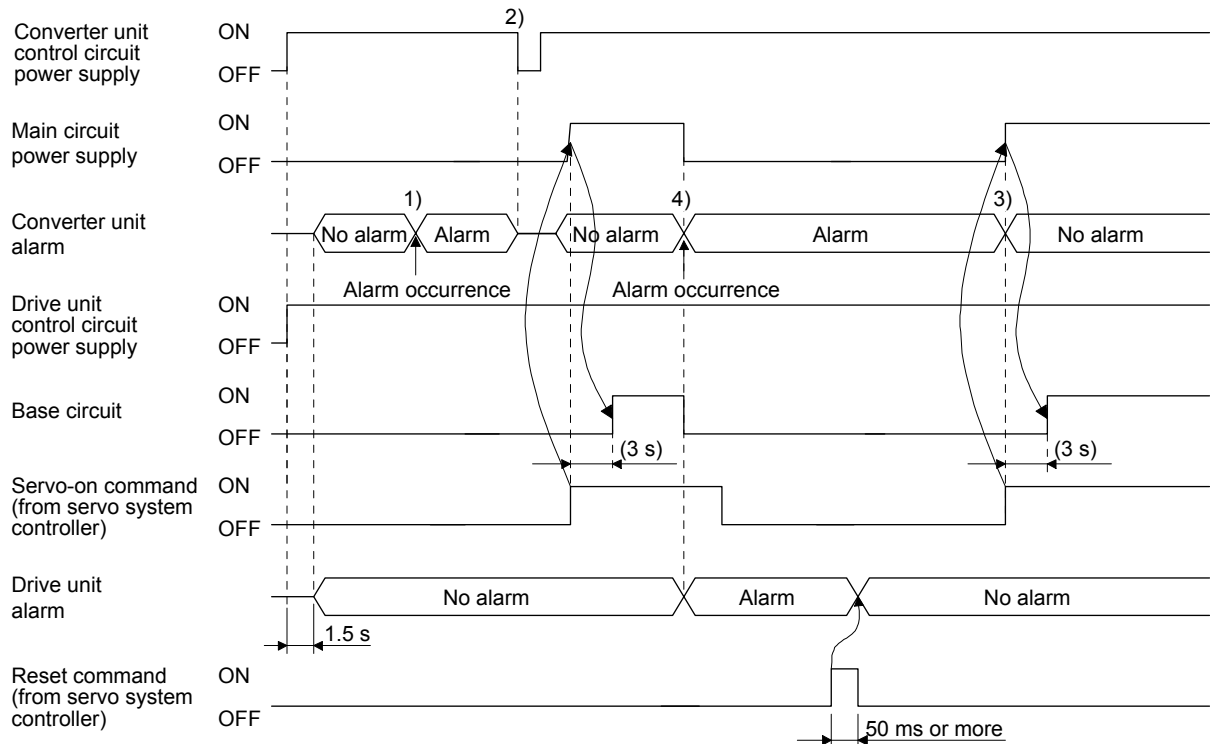

(1) in figure) When the drive unit is at servo-off, even if an alarm occurs in the converter, the drive unit does not detect the alarm.

(2) and 3) in figure) To deactivate the alarm of the converter unit, cycle the power of the converter unit (2), or turn on the servo-on command (3).

(4) in figure) If an alarm occurs in the converter unit when the drive unit is at servo-on, the alarm also occurs in the drive unit and the drive unit becomes servo-off.

3. SIGNALS AND WIRING

(b) Drive unit

When an alarm occurs on the drive unit, the base circuit is shut off and the servo motor coasts.

When an external dynamic brake (option) is used, the external dynamic brake is activated to stop the servo motor. To deactivate the alarm, cycle the control circuit power, or give the error reset or CPU reset command from the servo system controller. However, the alarm cannot be deactivated unless its cause is removed.

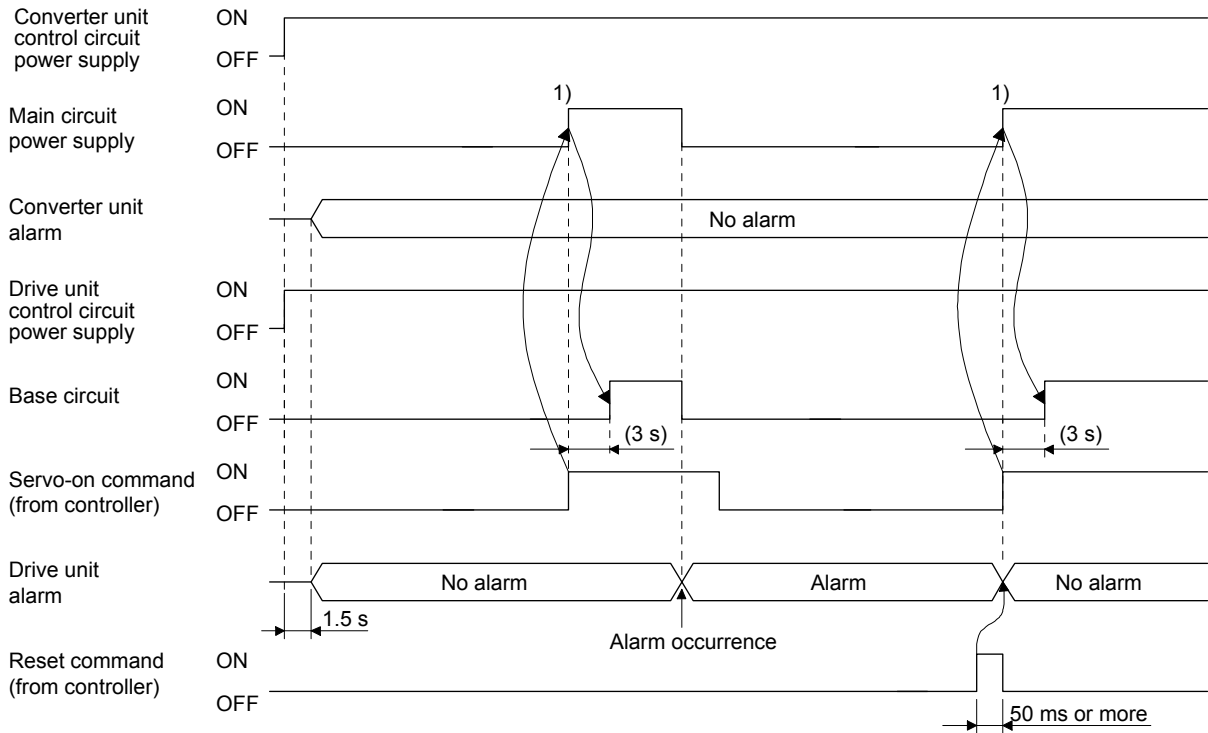

(1) in figure) After the start-up of the drive unit is completed, the main circuit power is supplied while the drive unit and the converter unit have no alarm.

3. SIGNALS AND WIRING

(2) When magnetic contactor drive output is disabled

(a) Converter unit

When an alarm occurs in the converter unit, the converter unit turns into servo-off, but the main circuit power supply is not shut off. Therefore, shut off the main circuit power supply using the external sequence. Cancel the alarm in the converter unit. If an alarm also occurs in the drive unit, cancel the alarm in the drive unit as well. Then, turn on the error reset command from the servo system controller to resume the operation.

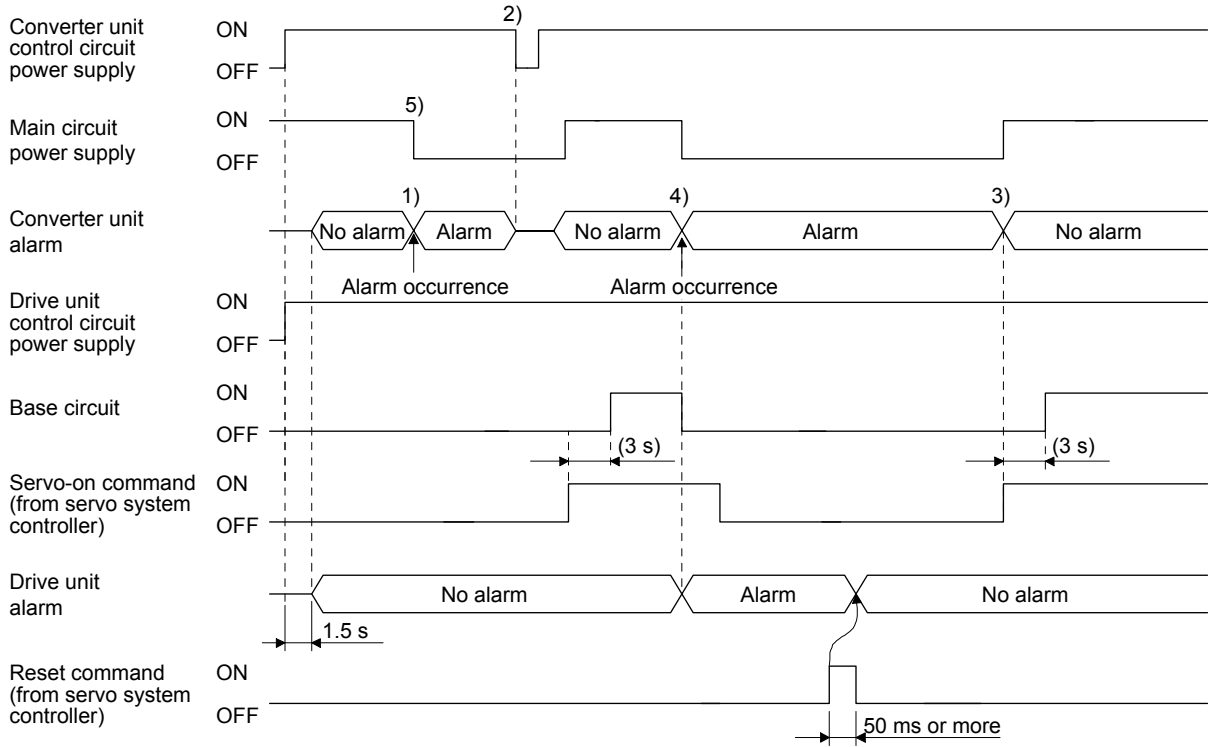

- (1) in figure) When the drive unit is at servo-off, even if an alarm occurs in the converter, the drive unit does not detect the alarm.
- (2) and 3) in figure) To deactivate the alarm of the converter unit, cycle the power of the converter unit (2), or turn on the servo-on command (3).
- (4) in figure) If an alarm occurs in the converter unit when the drive unit is at servo-on, the alarm also occurs in the drive unit and the drive unit becomes servo-off.
- (5) in figure) Shut off the main circuit power supply using the external sequence as soon as an alarm occurs.

3. SIGNALS AND WIRING

(b) Drive unit

When an alarm occurs in the drive unit, the drive unit turns into the servo-off, but the main circuit power supply is not shut off. Therefore, shut off the main circuit power supply using the external sequence. After cancelling the alarm in the drive unit, turn on the error reset command from the servo system controller to resume the operation.

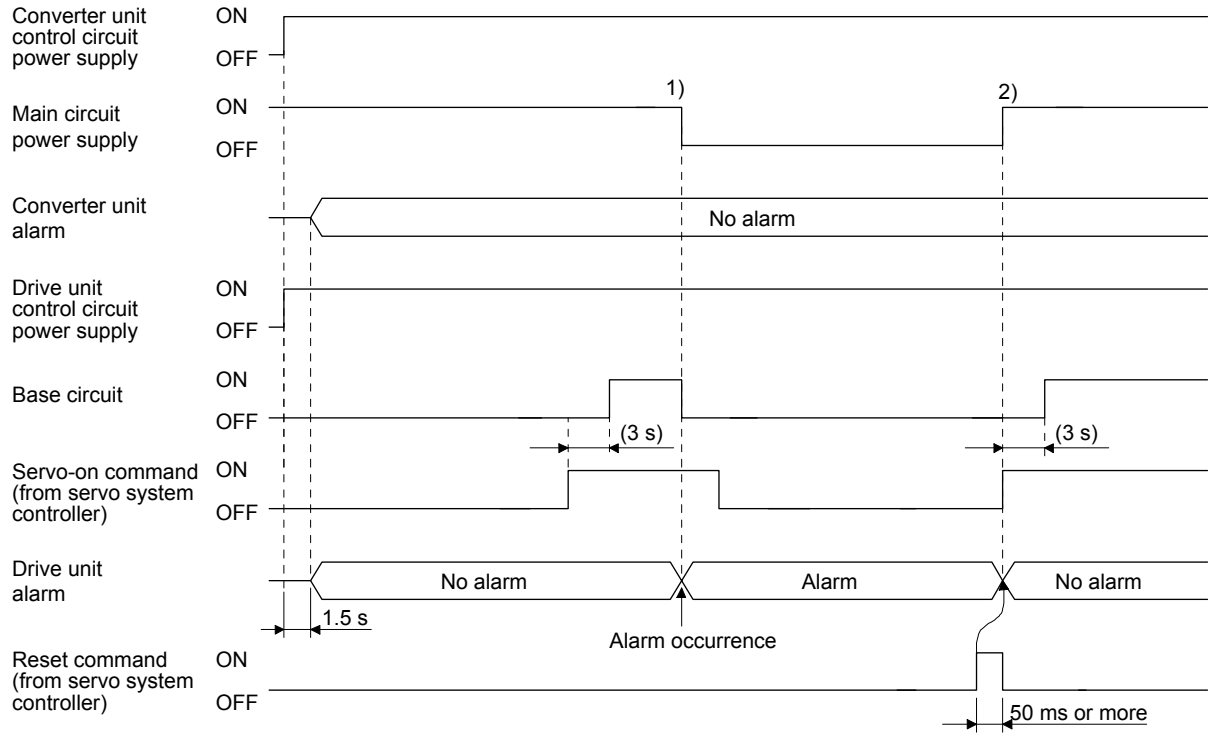

(1) in figure) When an alarm occurs in the drive unit, shut off the main circuit power supply using the external sequence.

(2) in figure) Turn on the main circuit power supply while an alarm in the drive unit is cancelled.

3. SIGNALS AND WIRING

3.5.3 Forced stop in the converter unit

(1) MR-J4-DU_A_(-RJ)

(a) When magnetic contactor drive output is enabled

When EM1 (Forced stop) is disabled in the converter unit, the magnetic contactor is turned off and the main circuit power supply is shut off. The drive unit in operation stops, and [AL. E9 Main circuit off warning] appears. When EM1 (Forced stop) is enabled in the converter unit, the magnetic contactor is turned on, the main circuit power is supplied, and then the drive unit automatically resumes the operation.

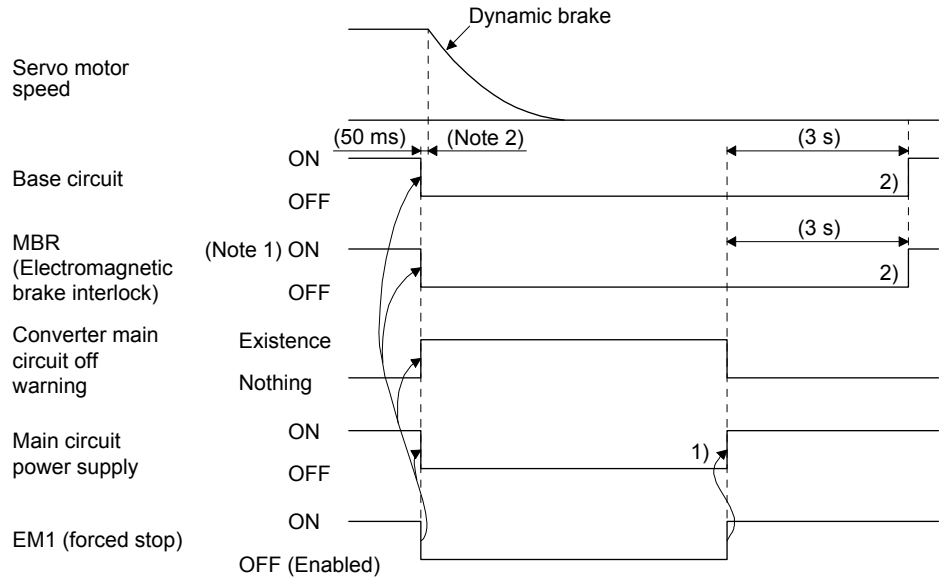

Note 1. When setting up an electromagnetic brake at customer's side, make up a sequence which will operate the electromagnetic brake as follow using MBR (Electromagnetic brake interlock).

ON: Electromagnetic brake is not activated.

OFF: Electromagnetic brake is activated.

2. There is delay caused by magnetic contactor built into the external dynamic brake (about 50 ms) and delay caused by the external relay.

(1) in figure) When EM1 (Forced stop) is enabled in the converter unit, the main circuit power is supplied.

(2) in figure) After the capacitor in the main circuit is fully charged, the base circuit and MBR (Electromagnetic brake interlock) turn on.

3. SIGNALS AND WIRING

(b) When magnetic contactor drive output is disabled

When EM1 (Forced stop) is disabled in the converter unit, the base circuit of the drive unit that is in operation shuts off, and [AL. E9 Main circuit off warning] appears on the drive unit. When EM1 (Forced stop) is enabled in the converter unit, the drive unit automatically resumes the operation.

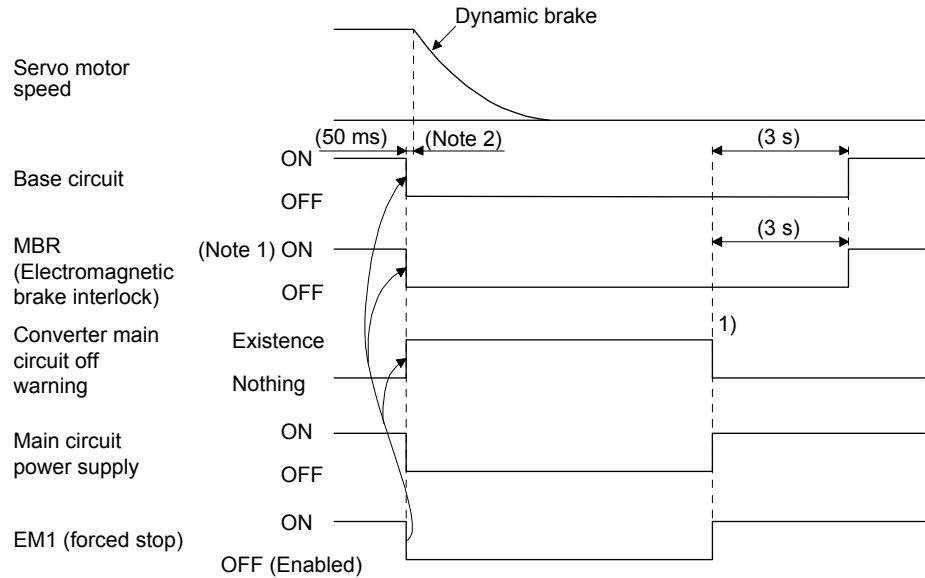

- Note 1. When setting up an electromagnetic brake at customer's side, make up a sequence which will operate the electromagnetic brake as follow using MBR (Electromagnetic brake interlock).
 ON: Electromagnetic brake is not activated.
 OFF: Electromagnetic brake is activated.
- Note 2. There is delay caused by magnetic contactor built into the external dynamic brake (about 50 ms) and delay caused by the external relay.

(1) in figure) When EM1 (Forced stop) is enabled, the main circuit off warning on the drive unit disappears.

3. SIGNALS AND WIRING

(2) MR-J4-DU_B_(-RJ)

(a) When magnetic contactor drive output is enabled

When EM1 (Forced stop) is disabled in the converter unit, the magnetic contactor is turned off and the main circuit power supply is shut off. The drive unit in operation stops, and [AL. E9 Main circuit off warning] appears. When EM1 (Forced stop) is enabled in the converter unit, the magnetic contactor is turned on, the main circuit power is supplied, and then the drive unit automatically resumes the operation.

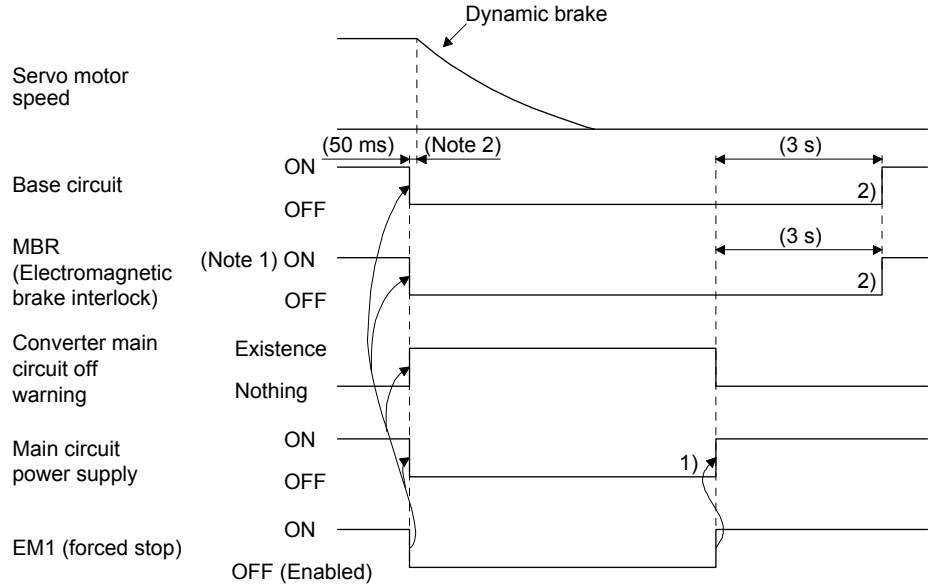

Note 1. When setting up an electromagnetic brake at customer's side, make up a sequence which will operate the electromagnetic brake as follow using MBR (Electromagnetic brake interlock).

ON: Electromagnetic brake is not activated.

OFF: Electromagnetic brake is activated.

Note 2. There is delay caused by magnetic contactor built into the external dynamic brake (about 50 ms) and delay caused by the external relay.

(1) in figure) When EM1 (Forced stop) is enabled in the converter unit, the main circuit power is supplied.

(2) in figure) After the capacitor in the main circuit is fully charged, the base circuit and MBR (Electromagnetic brake interlock) turn on.

3. SIGNALS AND WIRING

(b) When magnetic contactor drive output is disabled

When EM1 (Forced stop) is disabled in the converter unit, the base circuit of the drive unit that is in operation shuts off, and [AL. E9 Main circuit off warning] appears on the drive unit. When EM1 (Forced stop) is enabled in the converter unit, the drive unit automatically resumes the operation.

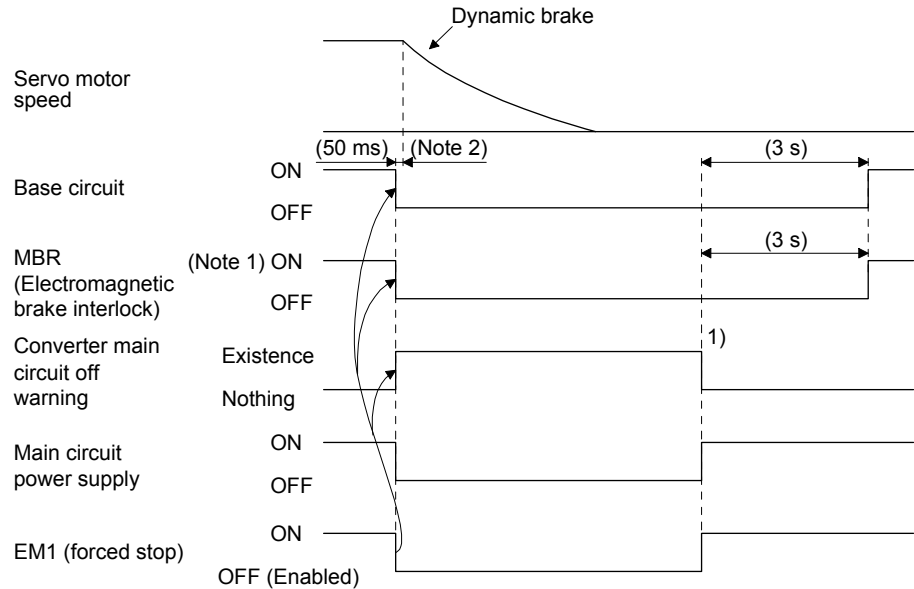

Note 1. When setting up an electromagnetic brake at customer's side, make up a sequence which will operate the electromagnetic brake as follow using MBR (Electromagnetic brake interlock).

ON: Electromagnetic brake is not activated.

OFF: Electromagnetic brake is activated.

Note 2. There is delay caused by magnetic contactor built into the external dynamic brake (about 50 ms) and delay caused by the external relay.

(1) in figure) When EM1 (Forced stop) is enabled, the main circuit off warning on the drive unit disappears.

3. SIGNALS AND WIRING

3.6 Interfaces

The interfaces of MR-J4-DU_(-RJ) are the same as those of MR-J4_(-RJ). For the MR-J4-DU_A_(-RJ), refer to section 3.9 of "MR-J4_A_(-RJ) Servo Amplifier Instruction Manual". For the MR-J4-DU_B_(-RJ), refer to section 3.8 of "MR-J4_B_(-RJ) Servo Amplifier Instruction Manual".

3.6.1 Detailed explanation of interfaces

This section provides the details of the I/O signal interfaces (refer to the I/O division in the table) given in section 3.4. Refer to this section and make connections to the external device.

(1) Digital input interface DI

This is an input circuit in which the cathode of the photocoupler is the input terminal. Transmit signals from sink (open-collector) type transistor output, relay switch, etc. The following shows a connection diagram for sink input. Refer to section 3.6.2 for source input.

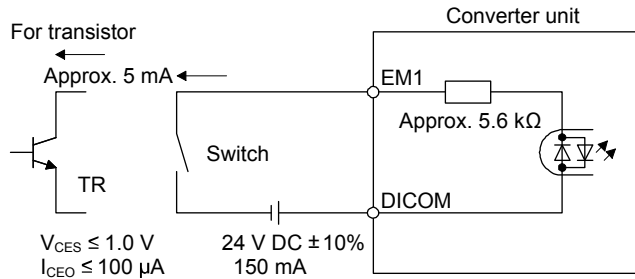

(2) Digital output interface DO

This is a circuit in which the collector of the output transistor is the output terminal. When the output transistor is turned on, the current will flow from the collector terminal.

A lamp, relay, or photocoupler can be driven. Install a diode (D) for an inductive load, or install an inrush current suppressing resistor (R) for a lamp load.

(Rated current: 40 mA or less, maximum current: 50 mA or less, inrush current: 100 mA or less)

A maximum of 2.6 V voltage drop occurs in the converter unit.

The following shows a connection diagram for sink output. Refer to section 3.6.2 for source output.

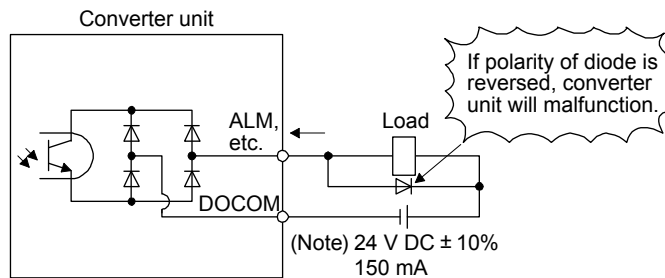

Note. If the voltage drop (maximum of 2.6 V) interferes with the relay operation, apply high voltage (maximum of 26.4 V) from external source.

3. SIGNALS AND WIRING

3.6.2 Source I/O interfaces

In this converter unit, source type I/O interfaces can be used.

(1) Digital input interface DI

This is an input circuit in which the anode of the photocoupler is the input terminal. Transmit signals from source (open-collector) type transistor output, relay switch, etc.

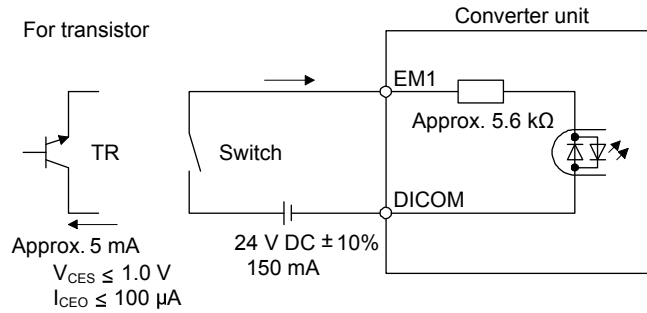

(2) Digital output interface DO

This is a circuit in which the emitter of the output transistor is the output terminal. When the output transistor is turned on, the current will flow from the output terminal to a load.

A maximum of 2.6 V voltage drop occurs in the converter unit.

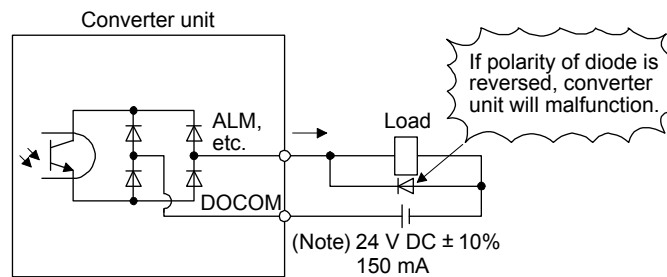

Note. If the voltage drop (maximum of 2.6 V) interferes with the relay operation, apply high voltage (maximum of 26.4 V) from external source.

3. SIGNALS AND WIRING

3.7 Grounding

⚠ WARNING

- Ground the converter unit, the drive unit and the servo motor securely.
- To prevent an electric shock, always connect the protective earth (PE) terminal (marked ⊕) of the converter unit and drive unit to the protective earth (PE) of the cabinet.

The drive unit switches the power transistor on-off to supply power to the servo motor. Depending on the wiring and ground cable routing, the drive unit may be affected by the switching noise (due to di/dt and dv/dt) of the transistor. To prevent such a fault, refer to the following diagram and always ground.

To conform to the EMC Directive, refer to the EMC Installation Guidelines (IB(NA)67310).

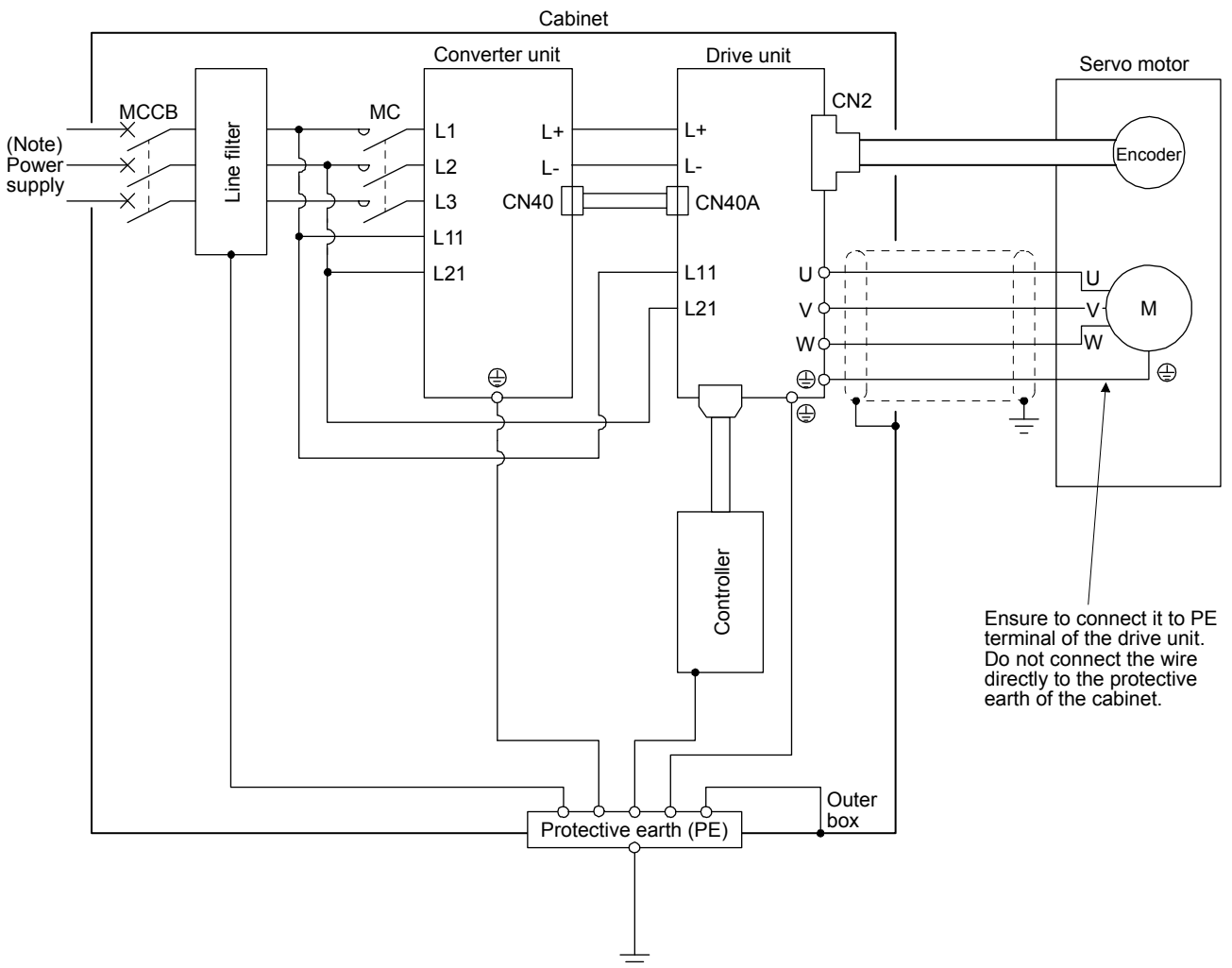

Note. Refer to section 1.2 for the power supply specifications.

4. STARTUP

4. STARTUP

 **WARNING** ● Do not operate the switches with wet hands. Otherwise, it may cause an electric shock.

 **CAUTION**

- Before starting operation, check the parameters. Improper settings may cause some machines to operate unexpectedly.
- The heat sink of the converter unit and the drive unit, the regenerative resistor, the servo motor, etc. may become hot while power is on or for some time after power-off. Take safety measures, such as providing covers, to avoid accidentally touching the parts (cables, etc.) by hand.
- During operation, never touch the rotor of the servo motor. Otherwise, it may cause injury.

The following items are the same as those of the MR-J4-_-(-RJ). For details of the items, refer to each chapter/section of the detailed explanation field. Read the corresponding section or chapter by replacing "servo amplifier" to "drive unit". "MR-J4-_A_" means "MR-J4-_A_(-RJ) Servo Amplifier Instruction Manual". "MR-J4-_B_" means "MR-J4-_B_(-RJ) Servo Amplifier Instruction Manual".

Model	Item	Detailed explanation
MR-J4-DU_A_(-RJ)	Display and operation section	MR-J4-_A_ section 4.5
MR-J4-DU_B_(-RJ)	Switch setting and display of the servo amplifier	MR-J4-_B_ section 4.3
	Test operation	MR-J4-_B_ section 4.4
	Test operation mode	MR-J4-_B_ section 4.5

4. STARTUP

4.1 Switching power on for the first time

When switching power on for the first time, follow this section to make a startup.

4.1.1 Startup procedure

(1) MR-J4-DU_A_(-RJ)

"MR-J4-_A_" means "MR-J4-_A_(-RJ) Servo Amplifier Instruction Manual".

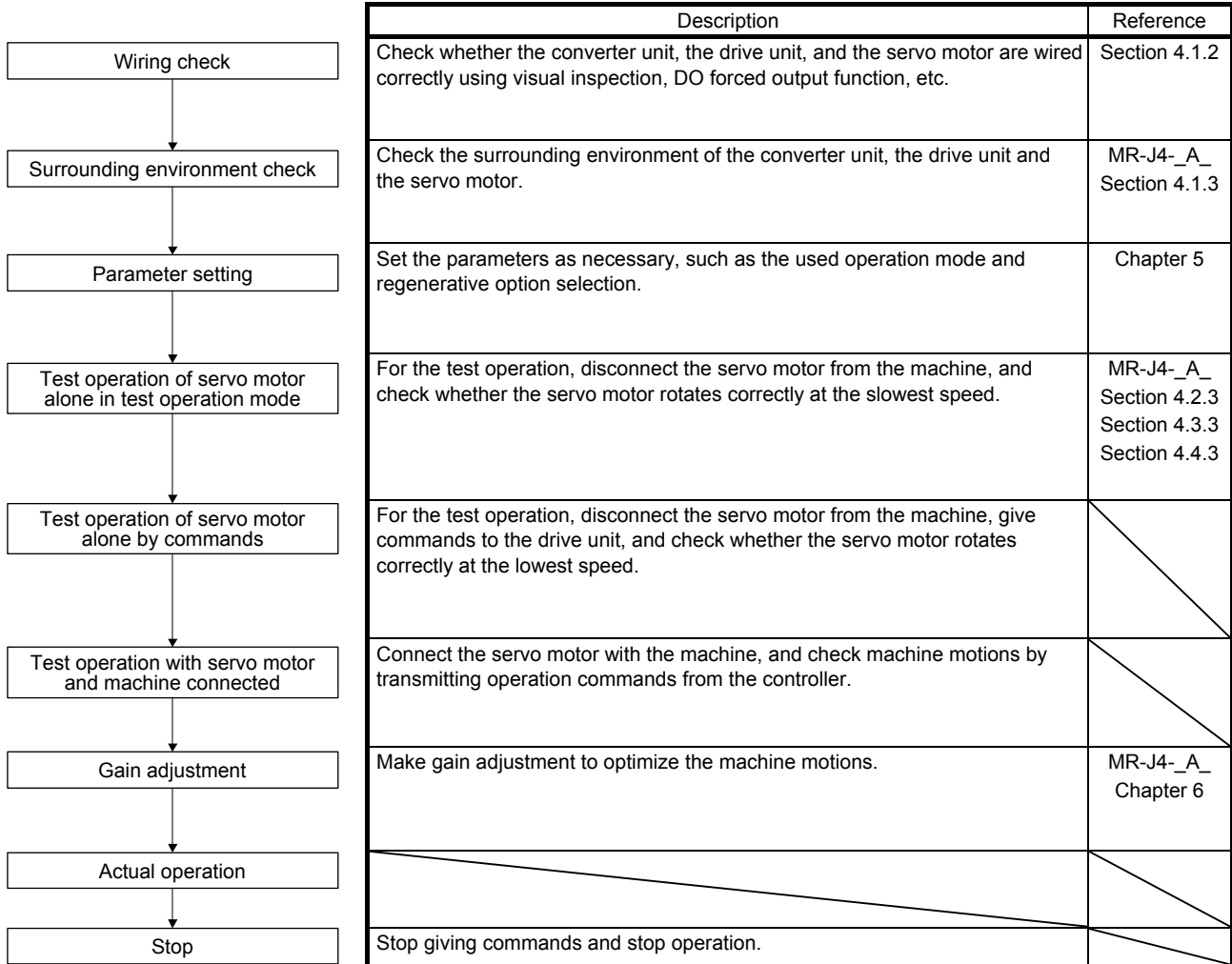

4. STARTUP

(2) MR-J4-DU_B_(-RJ)

"MR-J4-_B_" means "MR-J4-_B_(-RJ) Servo Amplifier Instruction Manual".

	Description	Reference
Wiring check	Check whether the converter unit, the drive unit, and the servo motor are wired correctly using visual inspection, DO forced output function, etc.	Section 4.1.2
Surrounding environment check	Check the surrounding environment of the converter unit, the drive unit and the servo motor.	MR-J4-_B_ Section 4.1.3
Axis No. settings	Confirm that the control axis No. set with the auxiliary axis number setting switches (SW2-3 and SW2-4) and with the axis selection rotary switch (SW1) match the control axis No. set with the servo system controller.	MR-J4-_B_ Section 4.3.1 (3)
Parameter setting	Set the parameters as necessary, such as the used operation mode and regenerative option selection.	Chapter 5
Test operation of servo motor alone in test operation mode	For the test operation, disconnect the servo motor from the machine, and check whether the servo motor rotates correctly at the slowest speed.	MR-J4-_B_ Section 4.5
Test operation of servo motor alone by commands	For the test operation, disconnect the servo motor from the machine, give commands to the drive unit, and check whether the servo motor rotates correctly at the lowest speed.	
Test operation with servo motor and machine connected	Connect the servo motor with the machine, and check machine motions by transmitting operation commands from the servo system controller.	
Gain adjustment	Make gain adjustment to optimize the machine motions.	MR-J4-_B_ Chapter 6
Actual operation		
Stop	Stop giving commands and stop operation.	

4. STARTUP

4.1.2 Wiring check

(1) Power supply system wiring

Before turning on the power supplies of the main circuit and the control circuit, check the following items.

(a) Power supply system wiring

- 1) The power supplied to the converter unit power input terminals (L1, L2, L3, L11, and L21) and the drive unit power input terminals (L11 and L21) should satisfy the defined specifications. (Refer to section 1.2.)
- 2) When magnetic contactor drive output is enabled, the magnetic contactor control connector (CNP1) should be connected to the coil of the magnetic contactor.
- 3) When the power factor improving DC reactor is not used, P1 and P2 in the converter unit should be connected.

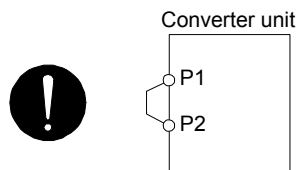

(b) Connection of drive unit and servo motor

- 1) The drive unit power outputs (U, V, and W) should match in phase with the servo motor power input terminals (U, V, and W).

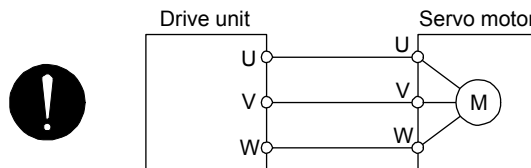

- 2) The power supplied to the converter unit should not be connected to the drive unit power outputs (U, V, and W). Doing so will fail the connected drive unit and servo motor.

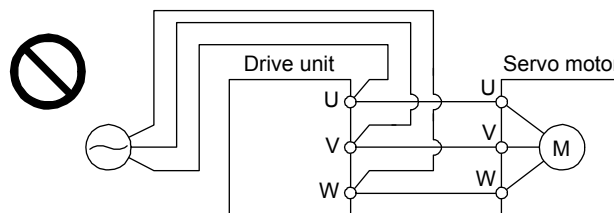

- 3) The grounding terminal of the servo motor is connected to the PE terminal of the drive unit.

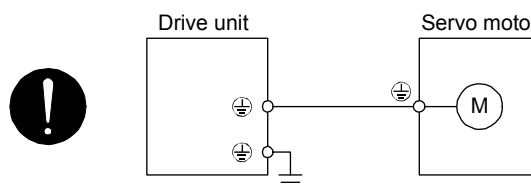

- 4) The CN2 connector of the drive unit should be connected to the encoder of the servo motor securely by using the encoder cable.

4. STARTUP

(c) When using options and peripheral equipment

1) When using a regenerative option

- The regenerative option should be connected to P+ and C terminals of the converter unit.
- A twisted wire should be used. (Refer to section 9.2.4.)

2) When using a brake unit

- The brake unit should be connected to L+ and L- terminals of TE2-1 of the converter unit. (Refer to section 9.10.3.)
- A twisted wire should be used for the wiring over 5 m and under 10 m when the brake unit is used. (Refer to section 9.10.3.)

3) The power factor improving DC reactor should be connected between P1 and P2 of the converter unit. (Refer to section 9.6.)

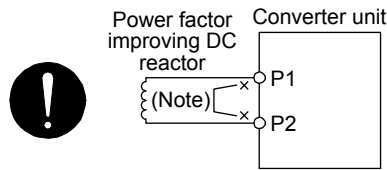

Note. Always disconnect wiring between P1 and P2.

(2) I/O signal wiring

(a) Converter unit

1) The I/O signals should be connected correctly.

Use DO forced output to forcibly turn on/off the pins of the CN1 connector. This function can be used to perform a wiring check. In this case, turn on the control circuit power supply only.

For details of I/O signal connection, refer to section 3.1.2. For details of DO forced output, refer to section 4.3.3 (3).

2) A voltage exceeding 24 V DC is not applied to the pins of the CN1 connector.

3) Between plate and DOCOM of the CN1 connector should not be shorted.

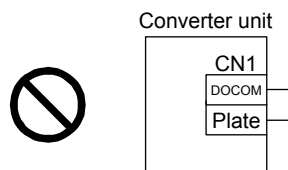

4. STARTUP

(b) Drive unit

1) MR-J4-DU_A_(-RJ)

a) The I/O signals should be connected correctly.

Use DO forced output to forcibly turn on/off the pins of the CN1 connector. This function can be used to perform a wiring check. In this case, turn on the control circuit power supply only.

For details of I/O signal connection, refer to section 3.2 of "MR-J4-_A_(-RJ) Servo Amplifier Instruction Manual". For details of DO forced output, refer to section 4.5.8 of "MR-J4-_A_(-RJ) Servo Amplifier Instruction Manual".

b) A voltage exceeding 24 V DC is not applied to the pins of the CN1 connector.

c) Between plate and DOCOM of the CN1 connector should not be shorted.

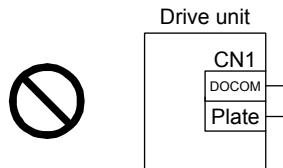

2) MR-J4-DU_B_(-RJ)

a) The I/O signals should be connected correctly.

Use DO forced output to forcibly turn on/off the pins of the CN3 connector. This function can be used to perform a wiring check. In this case, turn on the control circuit power supply only.

For details of I/O signal connection, refer to section 3.2 of "MR-J4-_B_(-RJ) Servo Amplifier Instruction Manual". For details of DO forced output, refer to section 4.5.1 of "MR-J4-_B_(-RJ) Servo Amplifier Instruction Manual".

b) A voltage exceeding 24 V DC is not applied to the pins of the CN3 connector.

c) Between plate and DOCOM of the CN3 connector should not be shorted.

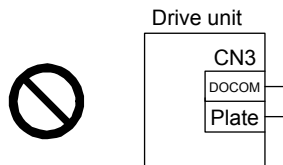

4. STARTUP

4.2 Startup

4.2.1 MR-J4-DU_A_(-RJ)

Startup of the MR-J4-DU_A_(-RJ) is the same as that of the MR-J4-_A_(-RJ). For details, refer to section 4.2 to 4.4 of "MR-J4-_A_(-RJ) Servo Amplifier Instruction Manual".

The converter unit display shows "ron" (ready-on) at power-on.

When an error occurs or EM1 (Forced stop) is disabled in the converter unit, the operation will stop.

4.2.2 MR-J4-DU_B_(-RJ)

Startup of the MR-J4-DU_B_(-RJ) is the same as that of the MR-J4-_B_(-RJ). For details, refer to section 4.2 of "MR-J4-_B_(-RJ) Servo Amplifier Instruction Manual".

The converter unit display shows "rof" (ready-off) at power-on.

When an error occurs or EM1 (Forced stop) is disabled in the converter unit, the operation will stop.

4. STARTUP

4.3 Display and operation section of the converter unit

4.3.1 Display flowchart

The converter unit has the display (3-digit, 7-segment LED) and the operation section (4 pushbuttons) for converter unit status display, alarm display, parameter setting, etc. Set the parameters before operation, diagnose an alarm, confirm external sequences, and/or confirm the operation status.

The following shows the operation procedure after power-on.

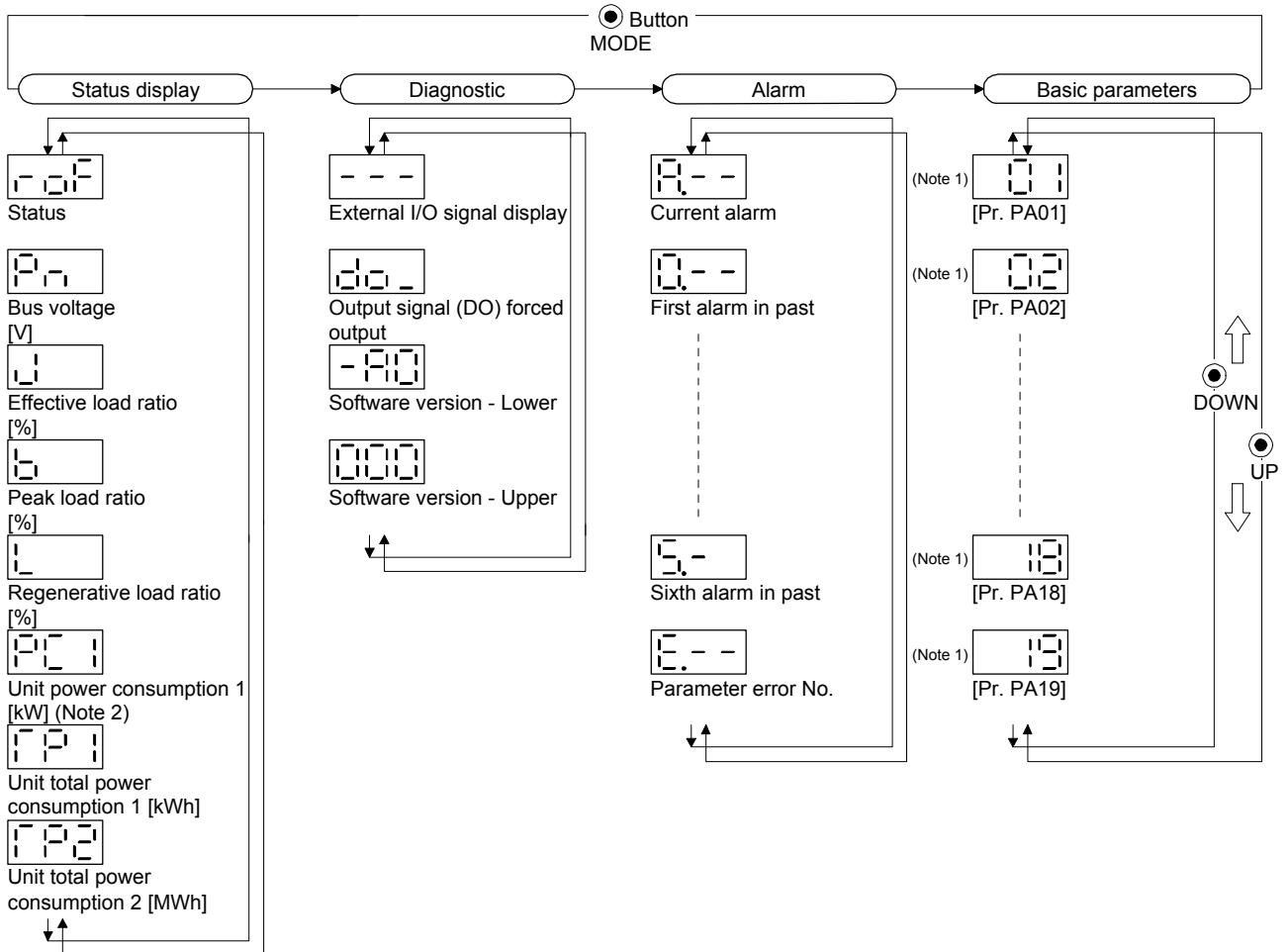

Note 1. When a parameter is selected, the parameter group and the parameter No. are displayed alternately. Refer to section 4.3.5 for details.

Note 2. The unit of unit power consumption 1 can be changed with [Pr. PA15].

4. STARTUP

4.3.2 Status display mode

The converter unit status during operation is shown on the 3-digit, 7-segment LED display. Press the "UP" or "DOWN" button to change display data as desired. When the required data is selected, the corresponding symbol is displayed. Press the "SET" button to display that data.

(1) Display examples

The following table shows the display examples.

Item	State	Displayed data
Status	Ready-off	roF
	Ready-on	ron
Bus voltage	300 [V]	300
Effective load ratio	67 [%]	67
Peak load ratio	95 [%]	95
Regenerative load ratio	90 [%]	90

(2) Status display list

The following table lists the converter unit statuses that may be displayed.

Status display	Symbol	Unit	Description	Indication range
Status	Ready-off		Ready-off is displayed during initialization or alarm occurrence, in the external forced stop status, or when the bus voltage is not established.	roF
	Ready-on		Ready-on is displayed when the servo was switched on after completion of initialization and the converter unit is ready to operate.	ron
Bus voltage	Pn	V	The bus voltage is displayed.	0 to 999
Effective load ratio	J	%	The effective load ratio in the past 15 s is displayed relative to the rated load of 100%.	0 to 300
Peak load ratio	b	%	The peak load ratio in the past 15 s is displayed relative to the rated load of 100%.	0 to 400
Regenerative load ratio	L	%	The ratio of regenerative power to permissible regenerative power is displayed in %.	0 to 300
Unit power consumption 1	PC1	kW (Note)	Unit power consumption is displayed by increment of 1 kW or 0.1 kW.	0 to 999
Unit total power consumption 1	TP1	kWh	Unit total power consumption is displayed by increment of 1 kWh.	0 to 999
Unit total power consumption 2	TP2	MWh	Unit total power consumption is displayed by increment of 1 MWh.	0 to 999

Note. The unit of unit power consumption 1 can be changed with [Pr. PA15].

4. STARTUP

4.3.3 Diagnostic mode

(1) Diagnostic list

Name	Display	Description
External I/O signal display		Indicates the on/off status of external I/O signal. Refer to (2) of this section for details.
Output signal (DO) forced output		Indicates that the digital output signal can be switched on/off forcibly. Refer to (3) of this section for details.
Software version - Lower		Indicates the version of the software.
Software version - Upper		Indicates the system number of the software.

(2) External I/O signal display

The on/off states of the digital I/O signals connected to the converter unit can be confirmed.

(a) Operation

The following shows the display screen at power-on. Using the "MODE" button, display the diagnostic screen.

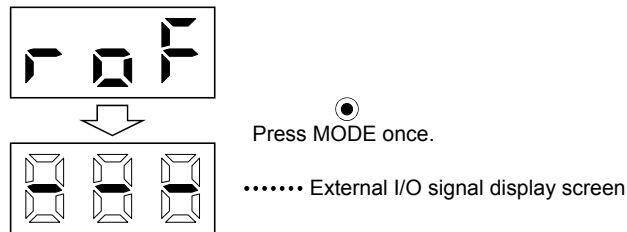

(b) Display definition

The LED segment corresponding to the pin is lit to indicate on, and is extinguished to indicate off. The 7-segment LED segments and CN1 connector pins correspond as shown below.

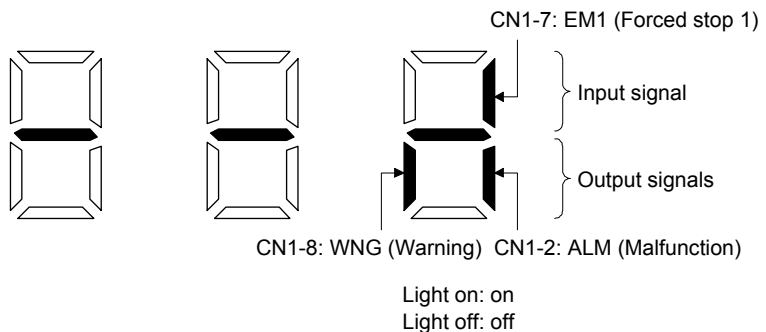

4. STARTUP

(3) Output signal (DO) forced output

Output signals can be forcibly switched on/off independently of the converter unit status. Use this function for checking output signal wiring, etc. The following shows the display screen at power-on. When turning CN1-8 on and off

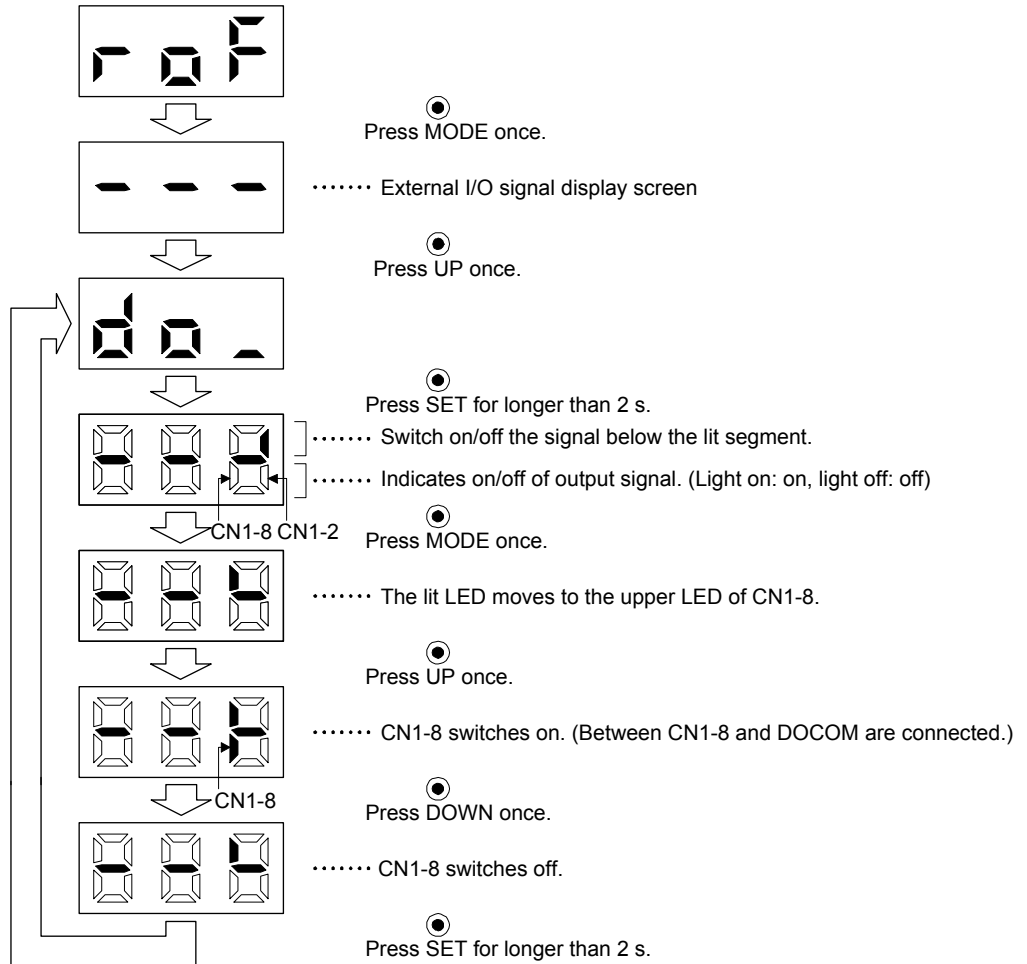

4. STARTUP

4.3.4 Alarm mode

The current alarm, past alarm history, and parameter error are displayed. The lower 2 digits on the display indicate the alarm number that has occurred or the parameter number in error.

Name	Display	Description
Current alarm		Indicates no occurrence of an alarm.
		Indicates that [AL. 33 Overvoltage] occurred. Flickers at alarm occurrence.
Alarm history		Indicates that the last alarm is [AL. 50 Overload 1].
		Indicates that the second alarm in the past is [AL. 33 Undervoltage].
		Indicates that the third alarm in the past is [AL. 10 Undervoltage].
		Indicates that the fourth alarm in the past is [AL. 10 Undervoltage].
		Indicates that the fifth alarm in the past is [AL. 10 Undervoltage].
		Indicates that the sixth alarm in the past is [AL. 50 Overload 1].
Parameter error No.		Indicates no occurrence of [AL. 37 Parameter error].
	 ↑ Displayed alternately 	Indicates that the data of [Pr. PA01 Regenerative option] is faulty.

4. STARTUP

Functions at alarm occurrence

- (1) Any mode screen displays the current alarm.
- (2) Even during alarm occurrence, the other screen can be viewed by pressing the button in the operation area. At this time, the decimal point in the third digit remains flickering.
- (3) For any alarm, remove its cause and clear it in any of the following methods. (Refer to chapter 6 for the alarms that can be cleared.)
 - (a) Switch power off, then on.
 - (b) Press the "SET" button on the current alarm screen.
- (4) Use [Pr. PA09] to clear the alarm history.

4.3.5 Parameter mode

POINT
<ul style="list-style-type: none"> ● The display of the converter unit has three digits. When a parameter No. is displayed, the parameter group and the parameter No. are displayed alternately. For example, when [Pr. PA01] is displayed, "PA" and "01" are displayed alternately.

The following example shows how to select MR-RB137 in [Pr. PA01 Regenerative option] after power-on.

raf

↓

PA

↔
Displayed alternately

01

↓

000

(Note)

↓

002

↓

002

● Press MODE three times.
..... The parameter number is displayed.
For [Pr. PA01], "PA" and "01" are displayed alternately.

● Press UP or DOWN to change the number.

● Press MODE twice.
..... The set value of the specified parameter number flickers. In this case, the lower three digits of the setting value "0 0 0 0" are displayed.

● Press MODE once.
..... During flickering, the set value can be changed.

● Use UP or DOWN. When a negative value is set, the decimal point flickers.
(_ _ _ 2: MR-RB137 (3 pcs.) are used.)

● Press SET to enter.

Note. When the lower three digits of the four digits are displayed, pressing the "MODE" button displays the fourth digit. However, do not change the setting of the fourth digit. Pressing the "MODE" button again resets the display to the lower three digits.

To shift to the next parameter, press the "UP" or "DOWN" button.

When changing the [Pr. PA01] setting, change its setting value, and then cycle the power to enable the new value.

5. PARAMETERS

5. PARAMETERS

⚠ CAUTION

- Never make a drastic adjustment or change to the parameter values as doing so will make the operation unstable.
- If fixed values are written in the digits of a parameter, do not change these values.
- Do not change parameters for manufacturer setting.
- Do not set a value other than the described values to each parameter.

5.1 Parameters for converter unit

5.1.1 Parameter list

POINT

- To enable a parameter whose symbol is preceded by *, cycle the power after setting it.

No.	Symbol	Name	Initial value	Unit
PA01	*REG	Regenerative option	0000h	
PA02	*MCC	Magnetic contactor drive output selection	0001h	
PA03		For manufacturer setting	0001h	
PA04			0	
PA05			100	
PA06			0	
PA07			100	
PA08	*DMD	Status display selection	0000h	
PA09	*BPS	Alarm history clear	0000h	
PA10		For manufacturer setting	0	
PA11			0000h	
PA12	*DIF	Input filter setting	0002h	
PA13		For manufacturer setting	0000h	
PA14			0000h	
PA15	AOP3	Function selection A-3	0000h	
PA16		For manufacturer setting	0000h	
PA17	*AOP5	Function selection A-5	0001h	
PA18	CVAT	SEMI-F47 function - Instantaneous power failure detection time	200	[ms]
PA19		For manufacturer setting	0000h	

5. PARAMETERS

5.1.2 Detailed list of parameters

POINT
● Set a value to each "x" in the "Setting digit" columns.

No./symbol/ name	Setting digit	Function	Initial value [unit]
PA01 *REG Regenerative option	__ x x	Regenerative option Select a regenerative option. Incorrect setting will trigger [AL. 37 Parameter error]. 00: Regenerative option is not used. When using the FR-BU2-(H) brake unit, select the value. 01: MR-RB139 02: MR-RB137 (3 pcs.) 13: MR-RB137-4 14: MR-RB13V-4 (3 pcs.)	00h
	_ x _ _	For manufacturer setting	0h
	x _ _ _		0h
PA02 *MCC Magnetic contactor drive output selection	___ x	Magnetic contactor drive output selection Select the magnetic contactor drive output. 0: Disabled 1: Enabled	1h
	_ _ x _	For manufacturer setting	0h
	_ x _ _		0h
PA08 *DMD Status display selection	___ x	Status display selection Select a status display shown at power-on. 0: Status 1: Bus voltage 2: Effective load ratio 3: Peak load ratio 4: Regenerative load ratio 5: Unit power consumption 1 6: Unit total power consumption 1 7: Unit total power consumption 2	0h
	_ _ x _	For manufacturer setting	0h
	_ x _ _		0h
PA09 *BPS Alarm history clear	___ x	Alarm history clear Used to clear the alarm history. 0: Disabled 1: Enabled When you select "Enabled", the alarm history will be cleared at next power-on. After the alarm history is cleared, the setting is automatically disabled.	0h
	_ _ x _	For manufacturer setting	0h
	_ x _ _		0h
	x _ _ _		0h

5. PARAMETERS

No./symbol/ name	Setting digit	Function	Initial value [unit]
PA12 *DIF Input filter setting	___x	Input filter setting Select the input filter. If external input signal causes chattering due to noise, etc., input filter is used to suppress it. 0: None 1: 1.777 [ms] 2: 3.555 [ms] 3: 5.333 [ms]	2h
	__x_	For manufacturer setting	0h
	_x__		0h
	x___		0h
PA15 AOP3 Function selection A-3	___x	Selection of unit power consumption display unit 0: increment of 1 kW 1: increment of 0.1 kW	0h
	__x_	For manufacturer setting	0h
	_x__		0h
	x___		0h
PA17 *AOP5 Function selection A-5	The [Pr. PA17 SEMI-F47 function selection] and [Pr. PA18 SEMI-F47 function - Instantaneous power failure detection time] settings of the converter unit must be the same as [Pr. PA20 SEMI-F47 function selection] and [Pr. PF25 SEMI-F47 function - Instantaneous power failure detection time] settings of the drive unit.		
	___x	[AL. 10 Undervoltage] detection method selection Set this parameter when [AL. 10 Undervoltage] occurs due to distorted power supply voltage waveform. 0: [AL. 10] not occurrence 1: [AL. 10] occurrence	1h
	__x_	SEMI-F47 function selection 0: Disabled 1: Enabled Selecting "1" enables to avoid triggering [AL. 10 Undervoltage] using the electrical energy charged in the capacitor in case that an instantaneous power failure occurs during operation. In [Pr. PA18 SEMI-F47 function - Instantaneous power failure detection time], set the time until the occurrence of [AL. 10 Undervoltage].	0h
	_x__	For manufacturer setting	0h
x___	0h		
PA18 CVAT SEMI-F47 function - Instantaneous power failure detection time	The [Pr. PA17 SEMI-F47 function selection] and [Pr. PA18 SEMI-F47 function - Instantaneous power failure detection time] settings of the converter unit must be the same as [Pr. PA20 SEMI-F47 function selection] and [Pr. PF25 SEMI-F47 function - Instantaneous power failure detection time] settings of the drive unit.		
		Set the time until the occurrence of [AL. 10 Undervoltage]. To disable the parameter setting value, select "Disabled (_ _ 0 _)" of "SEMI-F47 function selection" in [Pr. PA17]. Setting range: 30 to 200	200 [ms]

5. PARAMETERS

5.2 Parameters for drive unit

5.2.1 MR-J4-DU_A_(-RJ)

POINT
<ul style="list-style-type: none"> ● To enable a parameter whose symbol is preceded by *, cycle the power after setting it. ● Set a value to each "x" in the "Setting digit" columns.

The following shows parameter settings exclusively for the driver unit. Other parameters are the same as those of MR-J4-_A_(-RJ). Refer to chapter 5 of "MR-J4-_A_(-RJ) Servo Amplifier Instruction Manual".

No./symbol/ name	Setting digit	Function	Initial value [unit]
PA02 *REG Regenerative option	__ x x	Regenerative option Select a regenerative option. For the drive unit, select the regenerative option with the converter unit. Selecting other than "__ 0 0" or "__ 0 1" will trigger [AL. 37 Parameter error]. 00: Regenerative option is not used, or when you use a regenerative option, set the regenerative option with the converter unit. 01: FR-BU2-(H) When you use FR-BU2-(H), select "Mode 2 (___ 1)" of "Undervoltage alarm detection mode selection" in [Pr. PC27].	00h
	_ x _ _	For manufacturer setting	0h
	x _ _ _		0h
PA20 *TDS Tough drive setting		Alarms may not be avoided with the tough drive function depending on the situations of the power supply and load fluctuation. You can assign MTRR (During tough drive) to pins CN1-22 to CN1-25, CN1-49, CN1-13, and CN1-14 with [Pr. PD23] to [Pr. PD26], [Pr. PD28], and [Pr. PD47].	
	__ _ x	For manufacturer setting	0h
	__ x _	Vibration tough drive selection 0: Disabled 1: Enabled Selecting "1" enables to suppress vibrations by automatically changing setting values of [Pr. PB13 Machine resonance suppression filter 1] and [Pr. PB15 Machine resonance suppression filter 2] in case that the vibration exceeds the value of the oscillation level set in [Pr. PF23]. To output the oscillation detection alarm as a warning, set [Pr. PF24 Vibration tough drive function selection]. For details, refer to section 7.3 of "MR-J4-_A_(-RJ) Servo Amplifier Instruction Manual".	0h
	_ x _ _	SEMI-F47 function selection The [Pr. PA20 SEMI-F47 function selection] and [Pr. PF25 SEMI-F47 function - Instantaneous power failure detection time] settings of the drive unit must be the same as [Pr. PA17 SEMI-F47 function selection] and [Pr. PA18 SEMI-F47 function - Instantaneous power failure detection time] settings of the converter unit. 0: Disabled 1: Enabled Selecting "1" enables to avoid triggering [AL. 10 Undervoltage] using the electrical energy charged in the capacitor in case that an instantaneous power failure occurs during operation. In [Pr. PF25 SEMI-F47 function - Instantaneous power failure detection time], set the time until the occurrence of [AL. 10.1 Voltage drop in the control circuit power].	0h
	x _ _ _	For manufacturer setting	0h

5. PARAMETERS

No./symbol/ name	Setting digit	Function	Initial value [unit]
PF25 CVAT SEMI-F47 function - Instanta- neous power failure detection time		<p>The [Pr. PA20 SEMI-F47 function selection] and [Pr. PF25 SEMI-F47 function - Instantaneous power failure detection time] settings of the drive unit must be the same as [Pr. PA17 SEMI-F47 function selection] and [Pr. PA18 SEMI-F47 function - Instantaneous power failure detection time] settings of the converter unit.</p> <p>Set the time until the occurrence of [AL. 10.1 Voltage drop in the control circuit power]. To disable the parameter setting value, select "Disabled (_ 0 _)" of "SEMI-F47 function selection" in [Pr. PA20].</p> <p>Setting range: 30 to 200</p>	200 [ms]

5.2.2 MR-J4-DU_B_(-RJ)

POINT
<ul style="list-style-type: none"> ● When you connect the amplifier to a servo system controller, servo parameter values of the servo system controller will be written to each parameter. ● Setting may not be made to some parameters and their ranges depending on the servo system controller model, drive unit software version, and MR Configurator2 software version. For details, refer to the servo system controller user's manual. ● The parameter whose symbol is preceded by * is enabled with the following conditions: <ul style="list-style-type: none"> *: After setting the parameter, cycle the power or reset the controller. ** : After setting the parameter, cycle the power. ● Set a value to each "x" in the "Setting digit" columns.

The following shows parameter settings exclusively for the driver unit. Other parameters are the same as those of MR-J4-_B_(-RJ). Refer to chapter 5 of "MR-J4-_B_(-RJ) Servo Amplifier Instruction Manual".

5. PARAMETERS

No.	Symbol	Name and function	Initial value [unit]	Setting range															
PA02	**REG	Regenerative option Select a regenerative option. For the drive unit, select the regenerative option with the converter unit. Selecting other than " __ 0 0" or " __ 0 1" will trigger [AL. 37 Parameter error].	Refer to the "Name and function" column.																
		<table border="1"> <thead> <tr> <th>Setting digit</th> <th>Explanation</th> <th>Initial value</th> </tr> </thead> <tbody> <tr> <td>__ x x</td> <td>Regenerative option selection 00: Regenerative option is not used, or when you use a regenerative option, set the regenerative option with the converter unit. 01: FR-BU2-(H) When you use FR-BU2-(H), select "Mode 2 (__ 1)" of "Undervoltage alarm detection mode selection" in [Pr. PC20].</td> <td>00h</td> </tr> <tr> <td>_ x _ _</td> <td rowspan="2">For manufacturer setting</td> <td>0h</td> </tr> <tr> <td>x _ _ _</td> <td>0h</td> </tr> </tbody> </table>			Setting digit	Explanation	Initial value	__ x x	Regenerative option selection 00: Regenerative option is not used, or when you use a regenerative option, set the regenerative option with the converter unit. 01: FR-BU2-(H) When you use FR-BU2-(H), select "Mode 2 (__ 1)" of "Undervoltage alarm detection mode selection" in [Pr. PC20].	00h	_ x _ _	For manufacturer setting	0h	x _ _ _	0h				
		Setting digit			Explanation	Initial value													
		__ x x			Regenerative option selection 00: Regenerative option is not used, or when you use a regenerative option, set the regenerative option with the converter unit. 01: FR-BU2-(H) When you use FR-BU2-(H), select "Mode 2 (__ 1)" of "Undervoltage alarm detection mode selection" in [Pr. PC20].	00h													
_ x _ _	For manufacturer setting	0h																	
x _ _ _		0h																	
PA20	*TDS	Tough drive setting Alarms may not be avoided with the tough drive function depending on the situations of the power supply and load fluctuation. You can assign MTTT (During tough drive) to pins CN3-9, CN3-13, and CN3-15 with [Pr. PD07] to [Pr. PD09].	Refer to the "Name and function" column.																
		<table border="1"> <thead> <tr> <th>Setting digit</th> <th>Explanation</th> <th>Initial value</th> </tr> </thead> <tbody> <tr> <td>__ _ x</td> <td>For manufacturer setting</td> <td>0h</td> </tr> <tr> <td>_ _ x _</td> <td>Vibration tough drive selection 0: Disabled 1: Enabled Selecting "1" enables to suppress vibrations by automatically changing setting values of [Pr. PB13 Machine resonance suppression filter 1] and [Pr. PB15 Machine resonance suppression filter 2] in case that the vibration exceeds the value of the oscillation level set in [Pr. PF23]. For details, refer to section 7.3 of "MR-J4-_B_(-RJ) Servo Amplifier Instruction Manual".</td> <td>0h</td> </tr> <tr> <td>_ x _ _</td> <td>SEMI-F47 function selection The [Pr. PA20 SEMI-F47 function selection] and [Pr. PF25 SEMI-F47 function - Instantaneous power failure detection time] settings of the drive unit must be the same as [Pr. PA17 SEMI-F47 function selection] and [Pr. PA18 SEMI-F47 function - Instantaneous power failure detection time] settings of the converter unit. 0: Disabled 1: Enabled Selecting "1" enables to avoid triggering [AL. 10 Undervoltage] using the electrical energy charged in the capacitor in case that an instantaneous power failure occurs during operation. In [Pr. PF25 SEMI-F47 function - Instantaneous power failure detection time], set the time until the occurrence of [AL. 10.1 Voltage drop in the control circuit power].</td> <td>0h</td> </tr> <tr> <td>x _ _ _</td> <td>For manufacturer setting</td> <td>0h</td> </tr> </tbody> </table>			Setting digit	Explanation	Initial value	__ _ x	For manufacturer setting	0h	_ _ x _	Vibration tough drive selection 0: Disabled 1: Enabled Selecting "1" enables to suppress vibrations by automatically changing setting values of [Pr. PB13 Machine resonance suppression filter 1] and [Pr. PB15 Machine resonance suppression filter 2] in case that the vibration exceeds the value of the oscillation level set in [Pr. PF23]. For details, refer to section 7.3 of "MR-J4-_B_(-RJ) Servo Amplifier Instruction Manual".	0h	_ x _ _	SEMI-F47 function selection The [Pr. PA20 SEMI-F47 function selection] and [Pr. PF25 SEMI-F47 function - Instantaneous power failure detection time] settings of the drive unit must be the same as [Pr. PA17 SEMI-F47 function selection] and [Pr. PA18 SEMI-F47 function - Instantaneous power failure detection time] settings of the converter unit. 0: Disabled 1: Enabled Selecting "1" enables to avoid triggering [AL. 10 Undervoltage] using the electrical energy charged in the capacitor in case that an instantaneous power failure occurs during operation. In [Pr. PF25 SEMI-F47 function - Instantaneous power failure detection time], set the time until the occurrence of [AL. 10.1 Voltage drop in the control circuit power].	0h	x _ _ _	For manufacturer setting	0h
		Setting digit			Explanation	Initial value													
		__ _ x			For manufacturer setting	0h													
_ _ x _	Vibration tough drive selection 0: Disabled 1: Enabled Selecting "1" enables to suppress vibrations by automatically changing setting values of [Pr. PB13 Machine resonance suppression filter 1] and [Pr. PB15 Machine resonance suppression filter 2] in case that the vibration exceeds the value of the oscillation level set in [Pr. PF23]. For details, refer to section 7.3 of "MR-J4-_B_(-RJ) Servo Amplifier Instruction Manual".	0h																	
_ x _ _	SEMI-F47 function selection The [Pr. PA20 SEMI-F47 function selection] and [Pr. PF25 SEMI-F47 function - Instantaneous power failure detection time] settings of the drive unit must be the same as [Pr. PA17 SEMI-F47 function selection] and [Pr. PA18 SEMI-F47 function - Instantaneous power failure detection time] settings of the converter unit. 0: Disabled 1: Enabled Selecting "1" enables to avoid triggering [AL. 10 Undervoltage] using the electrical energy charged in the capacitor in case that an instantaneous power failure occurs during operation. In [Pr. PF25 SEMI-F47 function - Instantaneous power failure detection time], set the time until the occurrence of [AL. 10.1 Voltage drop in the control circuit power].	0h																	
x _ _ _	For manufacturer setting	0h																	
PF25	CVAT	The [Pr. PA20 SEMI-F47 function selection] and [Pr. PF25 SEMI-F47 function - Instantaneous power failure detection time] settings of the drive unit must be the same as [Pr. PA17 SEMI-F47 function selection] and [Pr. PA18 SEMI-F47 function - Instantaneous power failure detection time] settings of the converter unit.																	
		SEMI-F47 function - Instantaneous power failure detection time Set the time until the occurrence of [AL. 10.1 Voltage drop in the control circuit power]. To disable the parameter setting value, select "Disabled (_ 0 _)" of "SEMI-F47 function selection" in [Pr. PA20].	200 [ms]	30 to 200															

6. TROUBLESHOOTING

6. TROUBLESHOOTING

6.1 Troubleshooting for MR-CR55K(4) converter unit

POINT
● [AL. 37 Parameter error] and warnings are not recorded in the alarm history.

When an error occurs during operation, the corresponding alarm or warning is displayed. When an alarm or warning is displayed, refer to "MELSERVO-J4 Servo Amplifier Instruction Manual (Troubleshooting)" to remove the failure. When an alarm occurs, ALM will turn off.

6.1.1 Explanation for the lists

(1) No./Name

Indicates each No./Name of alarms or warnings.

(2) Alarm deactivation

After its cause has been removed, the alarm can be deactivated in any of the methods marked ○ in the alarm deactivation column. Warnings are automatically canceled after the cause of occurrence is removed. Alarms are deactivated with alarm reset or cycling the power.

Alarm deactivation	Explanation
Alarm reset	Push the "SET" button on the current alarm screen of the display.
Cycling the power	Turning off the power and on again

6.1.2 Alarm/warning list

	Display	Name	Alarm deactivation	
			Alarm reset	Cycling the power
Alarm	A.10	Undervoltage	○	○
	A.12	Memory error 1 (RAM)	/	○
	A.15	Memory error 2 (EEP-ROM)	/	○
	A.17	Board error	/	○
	A.19	Memory error 3 (Flash-ROM)	/	○
	A.30	Regenerative error	(Note)○	(Note)○
	A.33	Overvoltage	○	○
	A.37	Parameter error	/	○
	A.38	MC drive circuit error	/	○
	A.39	Open phase	/	○
	A.3A	Inrush current suppression circuit error	/	○
	A.45	Main circuit device overheat	(Note)○	(Note)○
	A.47	Cooling fan error	/	○
	A.50	Overload 1	(Note)○	(Note)○
	A.51	Overload 2	(Note)○	(Note)○
	888	Watchdog	/	○

	Display	Name
Warning	A.91	Converter overheat warning
	A.E0	Excessive regeneration warning
	A.E1	Overload warning 1
	A.E6	Converter forced stop warning
	A.E8	Cooling fan speed reduction warning

Note. Leave for about 30 minutes of cooling time after removing the cause of occurrence.

6. TROUBLESHOOTING

6.2 Troubleshooting for drive unit

POINT	
	<ul style="list-style-type: none"> ● As soon as an alarm occurs, turn SON (Servo-on) off and interrupt the power. ● [AL. 37 Parameter error] and warnings (except [AL. F0 Tough drive warning]) are not recorded in the alarm history.

When an error occurs during operation, the corresponding alarm or warning is displayed. When an alarm or warning is displayed, refer to "MELSERVO-J4 Servo Amplifier Instruction Manual (Troubleshooting)" to remove the failure. When an alarm occurs, ALM (Malfunction) will turn off.

6.2.1 Explanation for the lists

(1) No./Name/Detail No./Detail name

Indicates each No./Name/Detail No./Detail name of alarms or warnings.

(2) Stop method

For the alarms and warnings in which "SD" is written in the stop method column, the servo motor stops with the dynamic brake after forced stop deceleration. For the alarms and warnings in which "DB" is written in the stop method column, the servo motor stops with the dynamic brake without forced stop deceleration.

(3) Alarm deactivation

After its cause has been removed, the alarm can be deactivated in any of the methods marked ○ in the alarm deactivation column. Warnings are automatically canceled after the cause of occurrence is removed. Alarms are deactivated with alarm reset, CPU reset, or cycling the power.

(a) MR-J4-DU_A_(-RJ)

Alarm deactivation	Explanation
Alarm reset	1. Turning on RES (Reset) with input device 2. Pushing the "SET" button while the display of the drive unit is the current alarm display status 3. Pushing the "Occurring Alarm Reset" button in the "Alarm Display" window of MR Configurator2
Cycling the power	Turning off the power and on again

(b) MR-J4-DU_B_(-RJ)

Alarm deactivation	Explanation
Alarm reset	1. Error reset command from controller 2. Pushing the "Occurring Alarm Reset" button in the "Alarm Display" window of MR Configurator2
CPU reset	Resetting the controller itself
Cycling the power	Turning off the power and on again

(4) Alarm code

Alarm codes are outputted only from MR-J4-DU_A_(-RJ). To output alarm codes, set [Pr. PD34] to "_ _ _ 1" when using a MR-J4-DU_A_(-RJ). Alarm codes are outputted by on/off of bit 0 to bit 2. Warnings ([AL. 90] to [AL. F3]) do not have alarm codes. The alarm codes in the following table will be outputted when they occur. The alarm codes will not be outputted in normal condition.

6. TROUBLESHOOTING

6.2.2 Alarm list

	No.	Name	Detail No.	Detail name	Stop method (Note 2, 3)	Alarm deactivation			Alarm code (Note 8)		
						Alarm reset	CPU reset	Cycling the power	ACD2 (Bit 2)	ACD1 (Bit 1)	ACD0 (Bit 0)
Alarm	10	Undervoltage	10.1	Voltage drop in the control circuit power	DB	○	○	○	0	1	0
			10.2	Voltage drop in the main circuit power	SD	○	○	○			
	11	Switch setting error	11.1	Axis number setting error	DB	△	△	○	△	△	△
			11.2	Disabling control axis setting error	DB	△	△	○	△	△	△
	12	Memory error 1 (RAM)	12.1	RAM error 1	DB	△	△	○	0	0	0
			12.2	RAM error 2	DB	△	△	○			
			12.3	RAM error 3	DB	△	△	○			
			12.4	RAM error 4	DB	△	△	○			
			12.5	RAM error 5	DB	△	△	○			
	13	Clock error	13.1	Clock error 1	DB	△	△	○	0	0	0
			13.2	Clock error 2	DB	△	△	○			
	14	Control process error	14.1	Control process error 1	DB	△	△	○	0	0	0
			14.2	Control process error 2	DB	△	△	○			
			14.3	Control process error 3	DB	△	△	○			
			14.4	Control process error 4	DB	△	△	○			
			14.5	Control process error 5	DB	△	△	○			
			14.6	Control process error 6	DB	△	△	○			
			14.7	Control process error 7	DB	△	△	○			
			14.8	Control process error 8	DB	△	△	○			
			14.9	Control process error 9	DB	△	△	○			
			14.A	Control process error 10	DB	△	△	○			
	15	Memory error 2 (EEP-ROM)	15.1	EEP-ROM error at power on	DB	△	△	○	0	0	0
			15.2	EEP-ROM error during operation	DB	△	△	○			
			15.4	Home position information read error	DB	△	△	○			
	16	Encoder initial communication error 1	16.1	Encoder initial communication - Receive data error 1	DB	△	△	○	1	1	0
			16.2	Encoder initial communication - Receive data error 2	DB	△	△	○			
			16.3	Encoder initial communication - Receive data error 3	DB	△	△	○			
			16.5	Encoder initial communication - Transmission data error 1	DB	△	△	○			
			16.6	Encoder initial communication - Transmission data error 2	DB	△	△	○			
			16.7	Encoder initial communication - Transmission data error 3	DB	△	△	○			
			16.A	Encoder initial communication - Process error 1	DB	△	△	○			
			16.B	Encoder initial communication - Process error 2	DB	△	△	○			
16.C			Encoder initial communication - Process error 3	DB	△	△	○				
16.D			Encoder initial communication - Process error 4	DB	△	△	○				
16.E			Encoder initial communication - Process error 5	DB	△	△	○				
16.F			Encoder initial communication - Process error 6	DB	△	△	○				
17			Board error	17.1	Board error 1	DB	△	△			
	17.3	Board error 2		DB	△	△	○				
	17.4	Board error 3		DB	△	△	○				
	17.5	Board error 4		DB	△	△	○				
	17.6	Board error 5		DB	△	△	○				
	17.7	Board error 7		DB	△	△	○				
	17.8	Board error 6 (Note 6)		DB	△	△	○				

6. TROUBLESHOOTING

	No.	Name	Detail No.	Detail name	Stop method (Note 2, 3)	Alarm deactivation			Alarm code (Note 8)		
						Alarm reset	CPU reset	Cycling the power	ACD2 (Bit 2)	ACD1 (Bit 1)	ACD0 (Bit 0)
Alarm	19	Memory error 3 (Flash-ROM)	19.1	Flash-ROM error 1	DB	<input type="checkbox"/>	<input type="checkbox"/>	<input type="radio"/>	0	0	0
			19.2	Flash-ROM error 2	DB	<input type="checkbox"/>	<input type="checkbox"/>	<input type="radio"/>			
	1A	Servo motor combination error	1A.1	Servo motor combination error 1	DB	<input type="checkbox"/>	<input type="checkbox"/>	<input type="radio"/>	1	1	0
			1A.2	Servo motor control mode combination error	DB	<input type="checkbox"/>	<input type="checkbox"/>	<input type="radio"/>			
			1A.4	Servo motor combination error 2	DB	<input type="checkbox"/>	<input type="checkbox"/>	<input type="radio"/>			
	1B	Converter alarm	1B.1	Converter unit error	DB	<input type="checkbox"/>	<input type="checkbox"/>	<input type="radio"/>	0	1	0
	1E	Encoder initial communication error 2	1E.1	Encoder malfunction	DB	<input type="checkbox"/>	<input type="checkbox"/>	<input type="radio"/>	1	1	0
			1E.2	Load-side encoder malfunction	DB	<input type="checkbox"/>	<input type="checkbox"/>	<input type="radio"/>			
	1F	Encoder initial communication error 3	1F.1	Incompatible encoder	DB	<input type="checkbox"/>	<input type="checkbox"/>	<input type="radio"/>	1	1	0
			1F.2	Incompatible load-side encoder	DB	<input type="checkbox"/>	<input type="checkbox"/>	<input type="radio"/>			
	20	Encoder normal communication error 1	20.1	Encoder normal communication - Receive data error 1	DB	<input type="checkbox"/>	<input type="checkbox"/>	<input type="radio"/>	1	1	0
			20.2	Encoder normal communication - Receive data error 2	DB	<input type="checkbox"/>	<input type="checkbox"/>	<input type="radio"/>			
			20.3	Encoder normal communication - Receive data error 3	DB	<input type="checkbox"/>	<input type="checkbox"/>	<input type="radio"/>			
			20.5	Encoder normal communication - Transmission data error 1	DB	<input type="checkbox"/>	<input type="checkbox"/>	<input type="radio"/>			
			20.6	Encoder normal communication - Transmission data error 2	DB	<input type="checkbox"/>	<input type="checkbox"/>	<input type="radio"/>			
			20.7	Encoder normal communication - Transmission data error 3	DB	<input type="checkbox"/>	<input type="checkbox"/>	<input type="radio"/>			
			20.9	Encoder normal communication - Receive data error 4	DB	<input type="checkbox"/>	<input type="checkbox"/>	<input type="radio"/>			
			20.A	Encoder normal communication - Receive data error 5	DB	<input type="checkbox"/>	<input type="checkbox"/>	<input type="radio"/>			
	21	Encoder normal communication error 2	21.1	Encoder data error 1	DB	<input type="checkbox"/>	<input type="checkbox"/>	<input type="radio"/>	1	1	0
			21.2	Encoder data update error	DB	<input type="checkbox"/>	<input type="checkbox"/>	<input type="radio"/>			
			21.3	Encoder data waveform error	DB	<input type="checkbox"/>	<input type="checkbox"/>	<input type="radio"/>			
			21.4	Encoder non-signal error	DB	<input type="checkbox"/>	<input type="checkbox"/>	<input type="radio"/>			
			21.5	Encoder hardware error 1	DB	<input type="checkbox"/>	<input type="checkbox"/>	<input type="radio"/>			
			21.6	Encoder hardware error 2	DB	<input type="checkbox"/>	<input type="checkbox"/>	<input type="radio"/>			
			21.9	Encoder data error 2	DB	<input type="checkbox"/>	<input type="checkbox"/>	<input type="radio"/>			
	24	Main circuit error	24.1	Ground fault detected at hardware detection circuit	DB	<input type="checkbox"/>	<input type="checkbox"/>	<input type="radio"/>	1	0	0
			24.2	Ground fault detected by software detection function	DB	<input type="radio"/>	<input type="radio"/>	<input type="radio"/>			
	25	Absolute position erased	25.1	Servo motor encoder - Absolute position erased	DB	<input type="checkbox"/>	<input type="checkbox"/>	<input type="radio"/>	1	1	0
			25.2	Scale measurement encoder - Absolute position erased	DB	<input type="checkbox"/>	<input type="checkbox"/>	<input type="radio"/>			
	27	Initial magnetic pole detection error	27.1	Initial magnetic pole detection - Abnormal termination	DB	<input type="radio"/>	<input type="checkbox"/>	<input type="radio"/>	1	1	0
27.2			Initial magnetic pole detection - Time out error	DB	<input type="radio"/>	<input type="checkbox"/>	<input type="radio"/>				
27.3			Initial magnetic pole detection - Limit switch error	DB	<input type="radio"/>	<input type="checkbox"/>	<input type="radio"/>				
27.4			Initial magnetic pole detection - Estimated error	DB	<input type="radio"/>	<input type="checkbox"/>	<input type="radio"/>				
27.5			Initial magnetic pole detection - Position deviation error	DB	<input type="radio"/>	<input type="checkbox"/>	<input type="radio"/>				
27.6			Initial magnetic pole detection - Speed deviation error	DB	<input type="radio"/>	<input type="checkbox"/>	<input type="radio"/>				
27.7			Initial magnetic pole detection - Current error	DB	<input type="radio"/>	<input type="checkbox"/>	<input type="radio"/>				
28	Linear encoder error 2	28.1	Linear encoder - Environment error	DB	<input type="checkbox"/>	<input type="checkbox"/>	<input type="radio"/>	1	1	0	

6. TROUBLESHOOTING

	No.	Name	Detail No.	Detail name	Stop method (Note 2, 3)	Alarm deactivation			Alarm code (Note 8)		
						Alarm reset	CPU reset	Cycling the power	ACD2 (Bit 2)	ACD1 (Bit 1)	ACD0 (Bit 0)
Alarm	2A	Linear encoder error 1	2A.1	Linear encoder error 1-1	DB	<input type="checkbox"/>	<input type="checkbox"/>	<input type="checkbox"/>	1	1	0
			2A.2	Linear encoder error 1-2	DB	<input type="checkbox"/>	<input type="checkbox"/>	<input type="checkbox"/>			
			2A.3	Linear encoder error 1-3	DB	<input type="checkbox"/>	<input type="checkbox"/>	<input type="checkbox"/>			
			2A.4	Linear encoder error 1-4	DB	<input type="checkbox"/>	<input type="checkbox"/>	<input type="checkbox"/>			
			2A.5	Linear encoder error 1-5	DB	<input type="checkbox"/>	<input type="checkbox"/>	<input type="checkbox"/>			
			2A.6	Linear encoder error 1-6	DB	<input type="checkbox"/>	<input type="checkbox"/>	<input type="checkbox"/>			
			2A.7	Linear encoder error 1-7	DB	<input type="checkbox"/>	<input type="checkbox"/>	<input type="checkbox"/>			
			2A.8	Linear encoder error 1-8	DB	<input type="checkbox"/>	<input type="checkbox"/>	<input type="checkbox"/>			
	2B	Encoder counter error	2B.1	Encoder counter error 1	DB	<input type="checkbox"/>	<input type="checkbox"/>	<input type="checkbox"/>	1	1	0
			2B.2	Encoder counter error 2	DB	<input type="checkbox"/>	<input type="checkbox"/>	<input type="checkbox"/>			
	30	Regenerative error	30.1	Regeneration heat error	DB	<input type="checkbox"/> (Note 1)	<input type="checkbox"/> (Note 1)	<input type="checkbox"/> (Note 1)	0	0	1
			30.2	Regeneration signal error	DB	<input type="checkbox"/> (Note 1)	<input type="checkbox"/> (Note 1)	<input type="checkbox"/> (Note 1)			
			30.3	Regeneration feedback signal error	DB	<input type="checkbox"/> (Note 1)	<input type="checkbox"/> (Note 1)	<input type="checkbox"/> (Note 1)			
	31	Overspeed	31.1	Abnormal motor speed	SD	<input type="checkbox"/>	<input type="checkbox"/>	<input type="checkbox"/>	1	0	1
	32	Overcurrent	32.1	Overcurrent detected at hardware detection circuit (during operation)	DB	<input type="checkbox"/>	<input type="checkbox"/>	<input type="checkbox"/>	1	0	0
			32.2	Overcurrent detected at software detection function (during operation)	DB	<input type="checkbox"/>	<input type="checkbox"/>	<input type="checkbox"/>			
			32.3	Overcurrent detected at hardware detection circuit (during a stop)	DB	<input type="checkbox"/>	<input type="checkbox"/>	<input type="checkbox"/>			
			32.4	Overcurrent detected at software detection function (during a stop)	DB	<input type="checkbox"/>	<input type="checkbox"/>	<input type="checkbox"/>			
	33	Overvoltage	33.1	Main circuit voltage error	DB	<input type="checkbox"/>	<input type="checkbox"/>	<input type="checkbox"/>	0	0	1
	34	SSCNET receive error 1	34.1	SSCNET receive data error	SD	<input type="checkbox"/>	<input type="checkbox"/> (Note 5)	<input type="checkbox"/>	<input type="checkbox"/>	<input type="checkbox"/>	<input type="checkbox"/>
			34.2	SSCNET connector connection error	SD	<input type="checkbox"/>	<input type="checkbox"/>	<input type="checkbox"/>	<input type="checkbox"/>	<input type="checkbox"/>	<input type="checkbox"/>
			34.3	SSCNET communication data error	SD	<input type="checkbox"/>	<input type="checkbox"/>	<input type="checkbox"/>	<input type="checkbox"/>	<input type="checkbox"/>	<input type="checkbox"/>
			34.4	Hardware error signal detection	SD	<input type="checkbox"/>	<input type="checkbox"/>	<input type="checkbox"/>	<input type="checkbox"/>	<input type="checkbox"/>	<input type="checkbox"/>
			34.5	SSCNET receive data error (safety observation function)	SD	<input type="checkbox"/>	<input type="checkbox"/>	<input type="checkbox"/>	<input type="checkbox"/>	<input type="checkbox"/>	<input type="checkbox"/>
			34.6	SSCNET communication data error (safety observation function)	SD	<input type="checkbox"/>	<input type="checkbox"/>	<input type="checkbox"/>	<input type="checkbox"/>	<input type="checkbox"/>	<input type="checkbox"/>
	35	Command frequency error	35.1	Command frequency error	SD	<input type="checkbox"/>	<input type="checkbox"/>	<input type="checkbox"/>	1	0	1
36	SSCNET receive error 2	36.1	Continuous communication data error	SD	<input type="checkbox"/>	<input type="checkbox"/>	<input type="checkbox"/>	<input type="checkbox"/>	<input type="checkbox"/>	<input type="checkbox"/>	
		36.2	Continuous communication data error (safety observation function)	SD	<input type="checkbox"/>	<input type="checkbox"/>	<input type="checkbox"/>	<input type="checkbox"/>	<input type="checkbox"/>	<input type="checkbox"/>	
37	Parameter error	37.1	Parameter setting range error	DB	<input type="checkbox"/>	<input type="checkbox"/>	<input type="checkbox"/>	0	0	0	
		37.2	Parameter combination error	DB	<input type="checkbox"/>	<input type="checkbox"/>	<input type="checkbox"/>				
		37.3	Point table setting error	DB	<input type="checkbox"/>	<input type="checkbox"/>	<input type="checkbox"/>				
39	Program error	39.1	Program error	DB	<input type="checkbox"/>	<input type="checkbox"/>	<input type="checkbox"/>	0	0	0	
		39.2	Command argument external error	DB	<input type="checkbox"/>	<input type="checkbox"/>	<input type="checkbox"/>				
		39.3	Register No. error	DB	<input type="checkbox"/>	<input type="checkbox"/>	<input type="checkbox"/>				
		39.4	Non-correspondence command error	DB	<input type="checkbox"/>	<input type="checkbox"/>	<input type="checkbox"/>				
3A	Inrush current suppression circuit error	3A.1	Inrush current suppression circuit error	DB	<input type="checkbox"/>	<input type="checkbox"/>	<input type="checkbox"/>	0	0	0	
3D	Parameter setting error for driver communication	3D.1	Parameter combination error for driver communication on slave	DB	<input type="checkbox"/>	<input type="checkbox"/>	<input type="checkbox"/>	<input type="checkbox"/>	<input type="checkbox"/>	<input type="checkbox"/>	
		3D.2	Parameter combination error for driver communication on master	DB	<input type="checkbox"/>	<input type="checkbox"/>	<input type="checkbox"/>	<input type="checkbox"/>	<input type="checkbox"/>	<input type="checkbox"/>	
3E	Operation mode error	3E.1	Operation mode error	DB	<input type="checkbox"/>	<input type="checkbox"/>	<input type="checkbox"/>	0	0	0	
		3E.6	Operation mode switch error	DB	<input type="checkbox"/>	<input type="checkbox"/>	<input type="checkbox"/>				

6. TROUBLESHOOTING

	No.	Name	Detail No.	Detail name	Stop method (Note 2, 3)	Alarm deactivation			Alarm code (Note 8)		
						Alarm reset	CPU reset	Cycling the power	ACD2 (Bit 2)	ACD1 (Bit 1)	ACD0 (Bit 0)
Alarm	42	Servo control error (for linear servo motor and direct drive motor)	42.1	Servo control error by position deviation	DB	(Note 4)	(Note 4)	○	1	1	0
			42.2	Servo control error by speed deviation	DB	(Note 4)	(Note 4)	○			
			42.3	Servo control error by torque/thrust deviation	DB	(Note 4)	(Note 4)	○			
		Fully closed loop control error (during fully closed loop control)	42.8	Fully closed loop control error by position deviation	DB	(Note 4)	(Note 4)	○			
			42.9	Fully closed loop control error by speed deviation	DB	(Note 4)	(Note 4)	○			
			42.A	Fully closed loop control error by position deviation during command stop	DB	(Note 4)	(Note 4)	○			
	45	Main circuit device overheat	45.1	Main circuit device overheat error 1	SD	○ (Note 1)	○ (Note 1)	○ (Note 1)	0	1	1
			45.2	Main circuit device overheat error 2	SD	○ (Note 1)	○ (Note 1)	○ (Note 1)			
	46	Servo motor overheat	46.1	Abnormal temperature of servo motor 1	SD	○ (Note 1)	○ (Note 1)	○ (Note 1)	0	1	1
			46.2	Abnormal temperature of servo motor 2	SD	○ (Note 1)	○ (Note 1)	○ (Note 1)			
			46.3	Thermistor disconnected error	SD	○ (Note 1)	○ (Note 1)	○ (Note 1)			
			46.4	Thermistor circuit error	SD	○ (Note 1)	○ (Note 1)	○ (Note 1)			
			46.5	Abnormal temperature of servo motor 3	DB	○ (Note 1)	○ (Note 1)	○ (Note 1)			
			46.6	Abnormal temperature of servo motor 4	DB	○ (Note 1)	○ (Note 1)	○ (Note 1)			
	47	Cooling fan error	47.1	Cooling fan stop error	SD	△	△	○	0	1	1
			47.2	Cooling fan speed reduction error	SD	△	△	○			
	50	Overload 1	50.1	Thermal overload error 1 during operation	SD	○ (Note 1)	○ (Note 1)	○ (Note 1)	0	1	1
			50.2	Thermal overload error 2 during operation	SD	○ (Note 1)	○ (Note 1)	○ (Note 1)			
			50.3	Thermal overload error 4 during operation	SD	○ (Note 1)	○ (Note 1)	○ (Note 1)			
			50.4	Thermal overload error 1 during a stop	SD	○ (Note 1)	○ (Note 1)	○ (Note 1)			
			50.5	Thermal overload error 2 during a stop	SD	○ (Note 1)	○ (Note 1)	○ (Note 1)			
			50.6	Thermal overload error 4 during a stop	SD	○ (Note 1)	○ (Note 1)	○ (Note 1)			
	51	Overload 2	51.1	Thermal overload error 3 during operation	DB	○ (Note 1)	○ (Note 1)	○ (Note 1)	0	1	1
			51.2	Thermal overload error 3 during a stop	DB	○ (Note 1)	○ (Note 1)	○ (Note 1)			
	52	Error excessive	52.1	Excess droop pulse 1	SD	○	○	○	1	0	1
			52.3	Excess droop pulse 2	SD	○	○	○			
52.4			Error excessive during 0 torque limit	SD	○	○	○				
52.5			Excess droop pulse 3	DB	○	○	○				
54	Oscillation detection	54.1	Oscillation detection error	DB	○	○	○	0	1	1	
56	Forced stop error	56.2	Over speed during forced stop	DB	○	○	○	1	1	0	
		56.3	Estimated distance over during forced stop	DB	○	○	○				
61	Operation error	61.1	Point table setting error	DB	○	△	○	1	0	1	
63	STO timing error	63.1	STO1 off	DB	○	○	○	1	1	0	
		63.2	STO2 off	DB	○	○	○				
		63.5	STO by functional safety unit	DB	○	○	○				
64	Functional safety unit setting error	64.1	STO input error	DB	△	△	○	0	0	0	
		64.2	Compatibility mode setting error	DB	△	△	○				
		64.3	Operation mode setting error	DB	△	△	○				

6. TROUBLESHOOTING

	No.	Name	Detail No.	Detail name	Stop method (Note 2, 3)	Alarm deactivation			Alarm code (Note 8)		
						Alarm reset	CPU reset	Cycling the power	ACD2 (Bit 2)	ACD1 (Bit 1)	ACD0 (Bit 0)
Alarm	65	Functional safety unit connection error	65.1	Functional safety unit communication error 1	SD	/	/	○	0	0	0
			65.2	Functional safety unit communication error 2	SD	/	/	○			
			65.3	Functional safety unit communication error 3	SD	/	/	○			
			65.4	Functional safety unit communication error 4	SD	/	/	○			
			65.5	Functional safety unit communication error 5	SD	/	/	○			
			65.6	Functional safety unit communication error 6	SD	/	/	○			
			65.7	Functional safety unit communication error 7	SD	/	/	○			
			65.8	Functional safety unit shut-off signal error 1	DB	/	/	○			
			65.9	Functional safety unit shut-off signal error 2	DB	/	/	○			
	66	Encoder initial communication error (safety observation function)	66.1	Encoder initial communication - Receive data error 1 (safety observation function)	DB	/	/	○	1	1	0
			66.2	Encoder initial communication - Receive data error 2 (safety observation function)	DB	/	/	○			
			66.3	Encoder initial communication - Receive data error 3 (safety observation function)	DB	/	/	○			
			66.7	Encoder initial communication - Transmission data error 1 (safety observation function)	DB	/	/	○			
			66.9	Encoder initial communication - Process error 1 (safety observation function)	DB	/	/	○			
	67	Encoder normal communication error 1 (safety observation function)	67.1	Encoder normal communication - Receive data error 1 (safety observation function)	DB	/	/	○	1	1	0
			67.2	Encoder normal communication - Receive data error 2 (safety observation function)	DB	/	/	○			
			67.3	Encoder normal communication - Receive data error 3 (safety observation function)	DB	/	/	○			
			67.4	Encoder normal communication - Receive data error 4 (safety observation function)	DB	/	/	○			
			67.7	Encoder normal communication - Transmission data error 1 (safety observation function)	DB	/	/	○			
	68	STO diagnosis error	68.1	Mismatched STO signal error	DB	/	/	○	0	0	0

6. TROUBLESHOOTING

	No.	Name	Detail No.	Detail name	Stop method (Note 2, 3)	Alarm deactivation			Alarm code (Note 8)		
						Alarm reset	CPU reset	Cycling the power	ACD2 (Bit 2)	ACD1 (Bit 1)	ACD0 (Bit 0)
Alarm	70	Load-side encoder initial communication error 1	70.1	Load-side encoder initial communication - Receive data error 1	DB	/	/	○	1	1	0
			70.2	Load-side encoder initial communication - Receive data error 2	DB	/	/	○			
			70.3	Load-side encoder initial communication - Receive data error 3	DB	/	/	○			
			70.5	Load-side encoder initial communication - Transmission data error 1	DB	/	/	○			
			70.6	Load-side encoder initial communication - Transmission data error 2	DB	/	/	○			
			70.7	Load-side encoder initial communication - Transmission data error 3	DB	/	/	○			
			70.A	Load-side encoder initial communication - Process error 1	DB	/	/	○			
			70.B	Load-side encoder initial communication - Process error 2	DB	/	/	○			
			70.C	Load-side encoder initial communication - Process error 3	DB	/	/	○			
			70.D	Load-side encoder initial communication - Process error 4	DB	/	/	○			
			70.E	Load-side encoder initial communication - Process error 5	DB	/	/	○			
			70.F	Load-side encoder initial communication - Process error 6	DB	/	/	○			
	71	Load-side encoder normal communication error 1	71.1	Load-side encoder normal communication - Receive data error 1	DB	/	/	○	1	1	0
			71.2	Load-side encoder normal communication - Receive data error 2	DB	/	/	○			
			71.3	Load-side encoder normal communication - Receive data error 3	DB	/	/	○			
			71.5	Load-side encoder normal communication - Transmission data error 1	DB	/	/	○			
			71.6	Load-side encoder normal communication - Transmission data error 2	DB	/	/	○			
			71.7	Load-side encoder normal communication - Transmission data error 3	DB	/	/	○			
			71.9	Load-side encoder normal communication - Receive data error 4	DB	/	/	○			
			71.A	Load-side encoder normal communication - Receive data error 5	DB	/	/	○			
	72	Load-side encoder normal communication error 2	72.1	Load-side encoder data error 1	DB	/	/	○	1	1	0
			72.2	Load-side encoder data update error	DB	/	/	○			
			72.3	Load-side encoder data waveform error	DB	/	/	○			
			72.4	Load-side encoder non-signal error	DB	/	/	○			
			72.5	Load-side encoder hardware error 1	DB	/	/	○			
			72.6	Load-side encoder hardware error 2	DB	/	/	○			
			72.9	Load-side encoder data error 2	DB	/	/	○			

6. TROUBLESHOOTING

	No.	Name	Detail No.	Detail name	Stop method (Note 2, 3)	Alarm deactivation			Alarm code (Note 8)		
						Alarm reset	CPU reset	Cycling the power	ACD2 (Bit 2)	ACD1 (Bit 1)	ACD0 (Bit 0)
Alarm	74	Option card error 1	74.1	Option card error 1	DB	/	/	○	/	/	/
			74.2	Option card error 2	DB	/	/	○	/	/	/
			74.3	Option card error 3	DB	/	/	○	/	/	/
			74.4	Option card error 4	DB	/	/	○	/	/	/
			74.5	Option card error 5	DB	/	/	○	/	/	/
	75	Option card error 2	75.3	Option card connection error	DB	/	/	○	/	/	/
			75.4	Option card disconnected	DB	/	/	○	/	/	/
	79	Functional safety unit diagnosis error	79.1	Functional safety unit power voltage error	DB	○ (Note 7)	/	○	1	1	1
			79.2	Functional safety unit internal error	DB	/	○				
			79.3	Abnormal temperature of functional safety unit	SD	○ (Note 7)	/	○			
			79.4	Servo amplifier error	SD	/	○				
			79.5	Input device error	SD	/	○				
			79.6	Output device error	SD	/	○				
			79.7	Mismatched input signal error	SD	/	○				
	79.8	Position feedback fixing error	DB	/	○						
	7A	Parameter setting error (safety observation function)	7A.1	Parameter verification error (safety observation function)	DB	/	/	○	0	0	0
			7A.2	Parameter setting range error (safety observation function)	DB	/	/	○			
			7A.3	Parameter combination error (safety observation function)	DB	/	/	○			
			7A.4	Functional safety unit combination error (safety observation function)	DB	/	/	○			
	7B	Encoder diagnosis error (safety observation function)	7B.1	Encoder diagnosis error 1 (safety observation function)	DB	/	/	○	1	1	0
			7B.2	Encoder diagnosis error 2 (safety observation function)	DB	/	/	○			
			7B.3	Encoder diagnosis error 3 (safety observation function)	DB	/	/	○			
			7B.4	Encoder diagnosis error 4 (safety observation function)	DB	/	/	○			
	7C	Functional safety unit communication diagnosis error (safety observation function)	7C.1	Functional safety unit communication cycle error (safety observation function)	SD	○ (Note 7)	○	○	0	0	0
			7C.2	Functional safety unit communication data error (safety observation function)	SD	○ (Note 7)	○	○			
	7D	Safety observation error	7D.1	Stop observation error	DB	○ (Note 3)	/	○	1	1	1
7D.2			Speed observation error	DB	○ (Note 7)	/	○				
82	Master-slave operation error 1	82.1	Master-slave operation error 1	DB	○	○	○	/	/	/	
8A	USB communication time-out error/serial communication time-out error/Modbus-RTU communication time-out error	8A.1	USB communication time-out error/Serial communication time-out error	SD	○	○	○	0	0	0	
		8A.2	Modbus-RTU communication time-out error	SD	○	○	○				
8D	CC-Link IE communication error	8D.1	CC-Link IE communication error 1	SD	○	○	○	/	/	/	
		8D.2	CC-Link IE communication error 2	SD	○	○	○	/	/	/	
		8D.3	Master station setting error 1	DB	○	○	○	/	/	/	
		8D.5	Master station setting error 2	DB	/	○	○	/	/	/	
		8D.6	CC-Link IE communication error 3	SD	○	○	○	/	/	/	
		8D.7	CC-Link IE communication error 4	SD	○	○	○	/	/	/	
		8D.8	CC-Link IE communication error 5	SD	○	○	○	/	/	/	
		8D.9	Synchronization error 1	SD	/	○	○	/	/	/	
		8D.A	Synchronization error 2	SD	/	○	○	/	/	/	

6. TROUBLESHOOTING

	No.	Name	Detail No.	Detail name	Stop method (Note 2, 3)	Alarm deactivation			Alarm code (Note 8)		
						Alarm reset	CPU reset	Cycling the power	ACD2 (Bit 2)	ACD1 (Bit 1)	ACD0 (Bit 0)
Alarm	8E	USB communication error/serial communication error/Modbus-RTU communication error	8E.1	USB communication receive error/Serial communication receive error	SD	○	○	○	0	0	0
			8E.2	USB communication checksum error/Serial communication checksum error	SD	○	○	○			
			8E.3	USB communication character error/serial communication character error	SD	○	○	○			
			8E.4	USB communication command error/Serial communication command error	SD	○	○	○			
			8E.5	USB communication data number error/Serial communication data number error	SD	○	○	○			
			8E.6	Modbus-RTU communication receive error	SD	○	○	○			
			8E.7	Modbus-RTU communication message frame error	SD	○	○	○			
			8E.8	Modbus-RTU communication CRC error	SD	○	○	○			
	88888	Watchdog	8888_	Watchdog	DB	△	△	○	△	△	△

- Note
1. Leave for about 30 minutes of cooling time after removing the cause of occurrence.
 2. The following shows two stop methods of DB and SD.
DB: Stop with dynamic brake
SD: Forced stop deceleration
 3. This is applicable when [Pr. PA04] is set to the initial value. The stop system of SD can be changed to DB using [Pr. PA04].
 4. The alarm can be canceled by setting as follows:
For the fully closed loop control: set [Pr. PE03] to "1 _ _ _".
 5. In some controller communication status, the alarm factor may not be removed.
 6. This alarm will occur only in the J3 compatibility mode.
 7. Reset this while all the safety observation functions are stopped.
 8. Alarm codes are outputted only from MR-J4-DU_A_(-RJ). Refer to section 6.2.1 for details.

6.2.3 Warning list

	No.	Name	Detail No.	Detail name	Stop method (Note 2, 3)
Warning	90	Home position return incomplete warning	90.1	Home position return incomplete	△
			90.2	Home position return abnormal termination	△
			90.5	Z-phase unpassed	△
	91	Servo amplifier overheat warning (Note 1)	91.1	Main circuit device overheat warning	△
	92	Battery cable disconnection warning	92.1	Encoder battery cable disconnection warning	△
			92.3	Battery degradation	△
93	ABS data transfer warning	93.1	Magnetic pole detection incomplete warning at ABS data transfer request	△	

6. TROUBLESHOOTING

	No.	Name	Detail No.	Detail name	Stop method (Note 2, 3)
Warning	95	STO warning	95.1	STO1 off detection	DB
			95.2	STO2 off detection	DB
			95.3	STO warning 1 (safety observation function)	DB
			95.4	STO warning 2 (safety observation function)	DB
			95.5	STO warning 3 (safety observation function)	DB
	96	Home position setting warning	96.1	In-position warning at home positioning	
			96.2	Command input warning at home positioning	
			96.3	Servo off warning at home positioning	
			96.4	Magnetic pole detection incomplete warning at home positioning	
	97	Program operation disabled/next station position warning	97.1	Program operation disabled warning	
			97.2	Next station position warning	
	98	Software limit warning	98.1	Forward rotation-side software stroke limit reached	
			98.2	Reverse rotation-side software stroke limit reached	
	99	Stroke limit warning	99.1	Forward rotation stroke end off	(Note 4)
			99.2	Reverse rotation stroke end off	(Note 4)
	9A	Optional unit input data error warning	9A.1	Optional unit input data sign error	
			9A.2	Optional unit BCD input data error	
	9B	Error excessive warning	9B.1	Excess droop pulse 1 warning	
			9B.3	Excess droop pulse 2 warning	
			9B.4	Error excessive warning during 0 torque limit	
	9C	Converter warning	9C.1	Converter unit warning	
	9D	CC-Link IE warning 1	9D.1	Station number switch change warning	
			9D.2	Master station setting warning	
			9D.3	Overlapping station number warning	
			9D.4	Mismatched station number warning	
	9E	CC-Link IE warning 2	9E.1	CC-Link IE communication warning	
	9F	Battery warning	9F.1	Low battery	
			9F.2	Battery degradation warning	
	E0	Excessive regeneration warning	E0.1	Excessive regeneration warning	
	E1	Overload warning 1	E1.1	Thermal overload warning 1 during operation	
			E1.2	Thermal overload warning 2 during operation	
			E1.3	Thermal overload warning 3 during operation	
E1.4			Thermal overload warning 4 during operation		
E1.5			Thermal overload warning 1 during a stop		
E1.6			Thermal overload warning 2 during a stop		
E1.7			Thermal overload warning 3 during a stop		
E1.8			Thermal overload warning 4 during a stop		
E2	Servo motor overheat warning	E2.1	Servo motor temperature warning		

6. TROUBLESHOOTING

	No.	Name	Detail No.	Detail name	Stop method (Note 2, 3)
Warning	E3	Absolute position counter warning	E3.1	Multi-revolution counter travel distance excess warning	
			E3.2	Absolute position counter warning	
			E3.4	Absolute positioning counter EEPROM writing frequency warning	
			E3.5	Encoder absolute positioning counter warning	
	E4	Parameter warning	E4.1	Parameter setting range error warning	
	E5	ABS time-out warning	E5.1	Time-out during ABS data transfer	
			E5.2	ABSM off during ABS data transfer	
			E5.3	SON off during ABS data transfer	
	E6	Servo forced stop warning	E6.1	Forced stop warning	SD
			E6.2	SS1 forced stop warning 1 (safety observation function)	SD
			E6.3	SS1 forced stop warning 2 (safety observation function)	SD
	E7	Controller forced stop warning	E7.1	Controller forced stop input warning	SD
	E8	Cooling fan speed reduction warning	E8.1	Decreased cooling fan speed warning	
			E8.2	Cooling fan stop	
	E9	Main circuit off warning	E9.1	Servo-on signal on during main circuit off	DB
			E9.2	Bus voltage drop during low speed operation	DB
			E9.3	Ready-on signal on during main circuit off	DB
			E9.4	Converter unit forced stop	DB
	EA	ABS servo-on warning	EA.1	ABS servo-on warning	
	EB	The other axis error warning	EB.1	The other axis error warning	DB
	EC	Overload warning 2	EC.1	Overload warning 2	
	ED	Output watt excess warning	ED.1	Output watt excess warning	
	F0	Tough drive warning	F0.1	Instantaneous power failure tough drive warning	
			F0.3	Vibration tough drive warning	
	F2	Drive recorder - Miswriting warning	F2.1	Drive recorder - Area writing time-out warning	
			F2.2	Drive recorder - Data miswriting warning	
	F3	Oscillation detection warning	F3.1	Oscillation detection warning	
	F5	Simple cam function - Cam data miswriting warning	F5.1	Cam data - Area writing time-out warning	
			F5.2	Cam data - Area miswriting warning	
			F5.3	Cam data checksum error	
	F6	Simple cam function - Cam control warning	F6.1	Cam axis one cycle current value restoration failed	
F6.2			Cam axis feed current value restoration failed		
F6.3			Cam unregistered error		
F6.4			Cam control data setting range error		
F6.5			Cam No. external error		
F6.6			Cam control inactive		

- Note
1. Leave for about 30 minutes of cooling time after removing the cause of occurrence.
 2. The following shows two stop methods of DB and SD.
DB: Stop with dynamic brake
SD: Forced stop deceleration
 3. This is applicable when [Pr. PA04] is set to the initial value. The stop system of SD can be changed to DB using [Pr. PA04].
 4. Quick stop or slow stop can be selected using [Pr. PD30].

7. DIMENSIONS

7. DIMENSIONS

POINT

● Refer to section 2.1 for the mounting hole process drawing.

7.1 Converter unit (MR-CR55K_)

[Unit: mm]

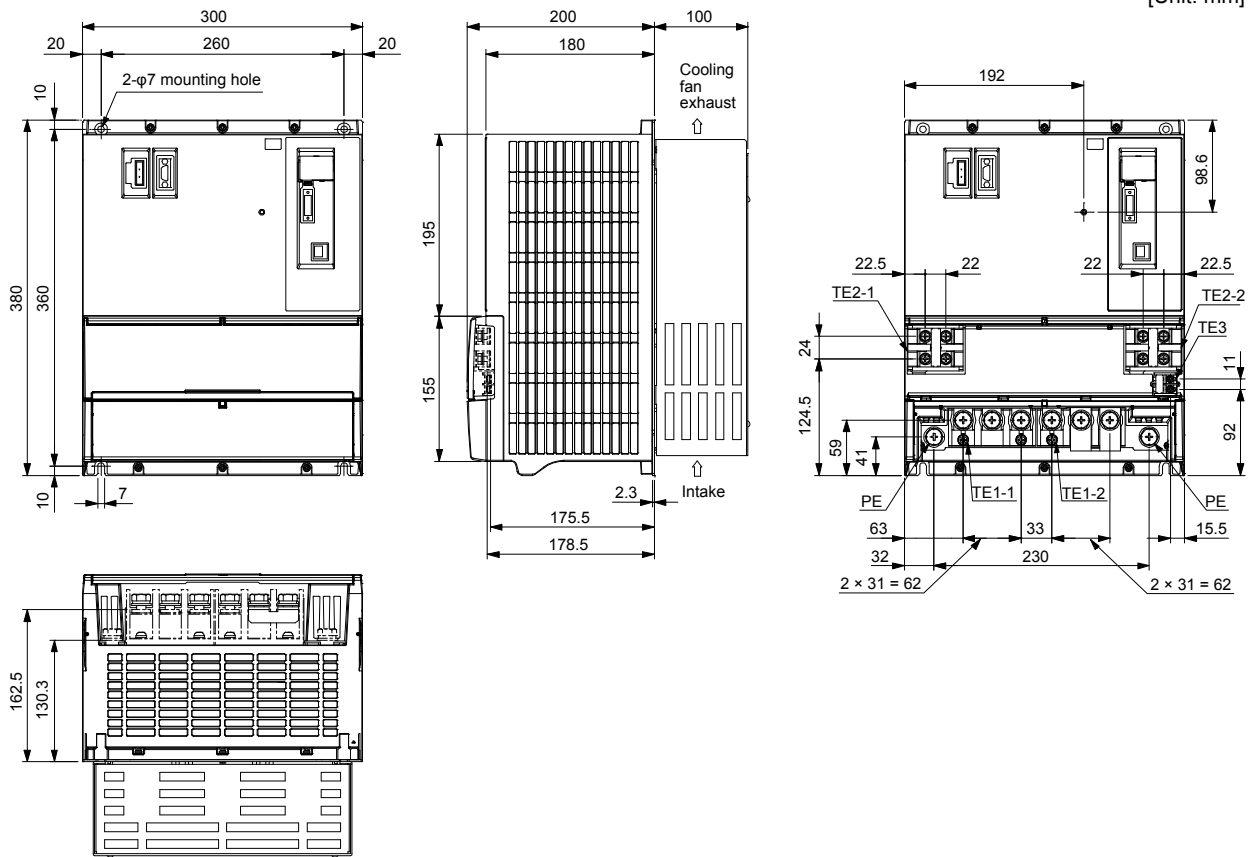

Mass: 22 [kg]

Mounting screw
Screw size: M6
Tightening torque: 5.49 [N•m]

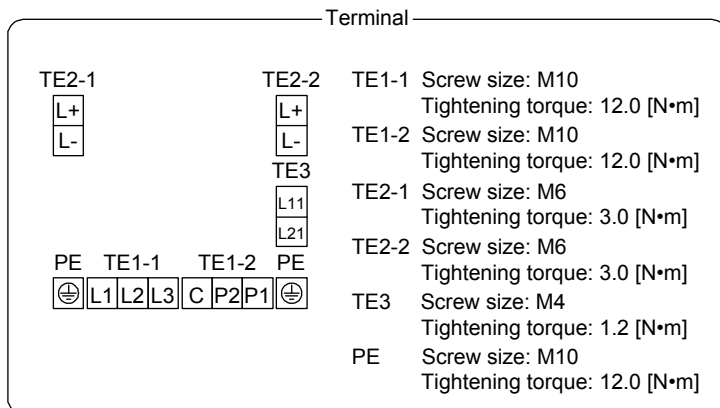

7. DIMENSIONS

7.2 Drive unit

7.2.1 MR-J4-DU_A_(-RJ)

POINT

● Only MR-J4-DU_A_-RJ is shown for dimensions. MR-J4-DU_A_ does not have CN2L connector. The dimensions of MR-J4-DU_A_ are the same as those of MR-J4-DU_A_-RJ except CN2L connector.

(1) MR-J4-DU30KA(-RJ)/MR-J4-DU37KA(-RJ)/MR-J4-DU45KA4(-RJ)/MR-J4-DU55KA4(-RJ)

[Unit: mm]

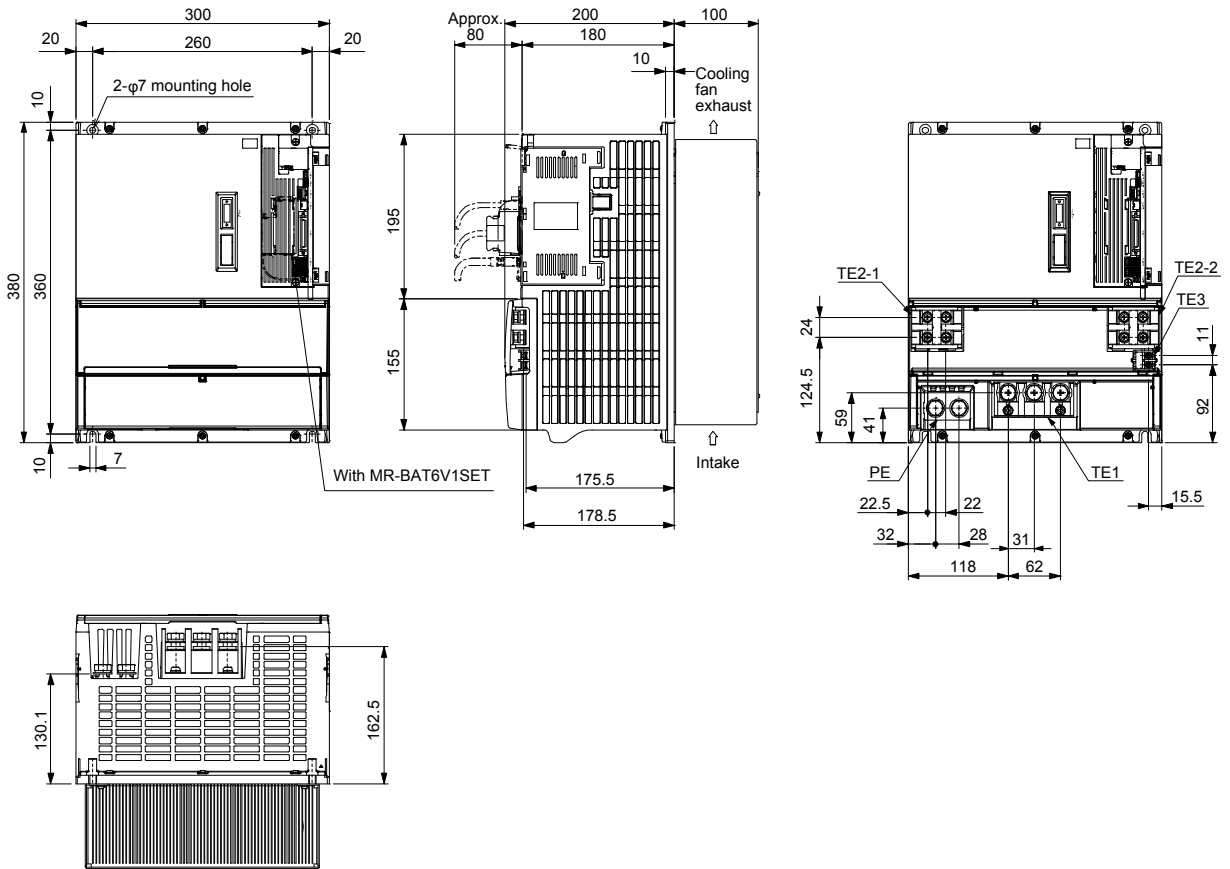

Terminal		
TE2-1	TE2-2	TE1
L+	L+	Screw size: M10
L-	L-	Tightening torque: 12.0 [N·m]
	TE3	TE2-1
	L11	Screw size: M6
	L21	Tightening torque: 3.0 [N·m]
PE	TE1	TE2-2
⊕ ⊖	U V W	Screw size: M6
		Tightening torque: 3.0 [N·m]
		TE3
		Screw size: M4
		Tightening torque: 1.2 [N·m]
		PE
		Screw size: M10
		Tightening torque: 12.0 [N·m]

Mass: 21 [kg]
 Mounting screw
 Screw size: M6
 Tightening torque: 5.49 [N·m]

7. DIMENSIONS

(2) MR-J4-DU30KA4(-RJ)/MR-J4-DU37KA4(-RJ)

[Unit: mm]

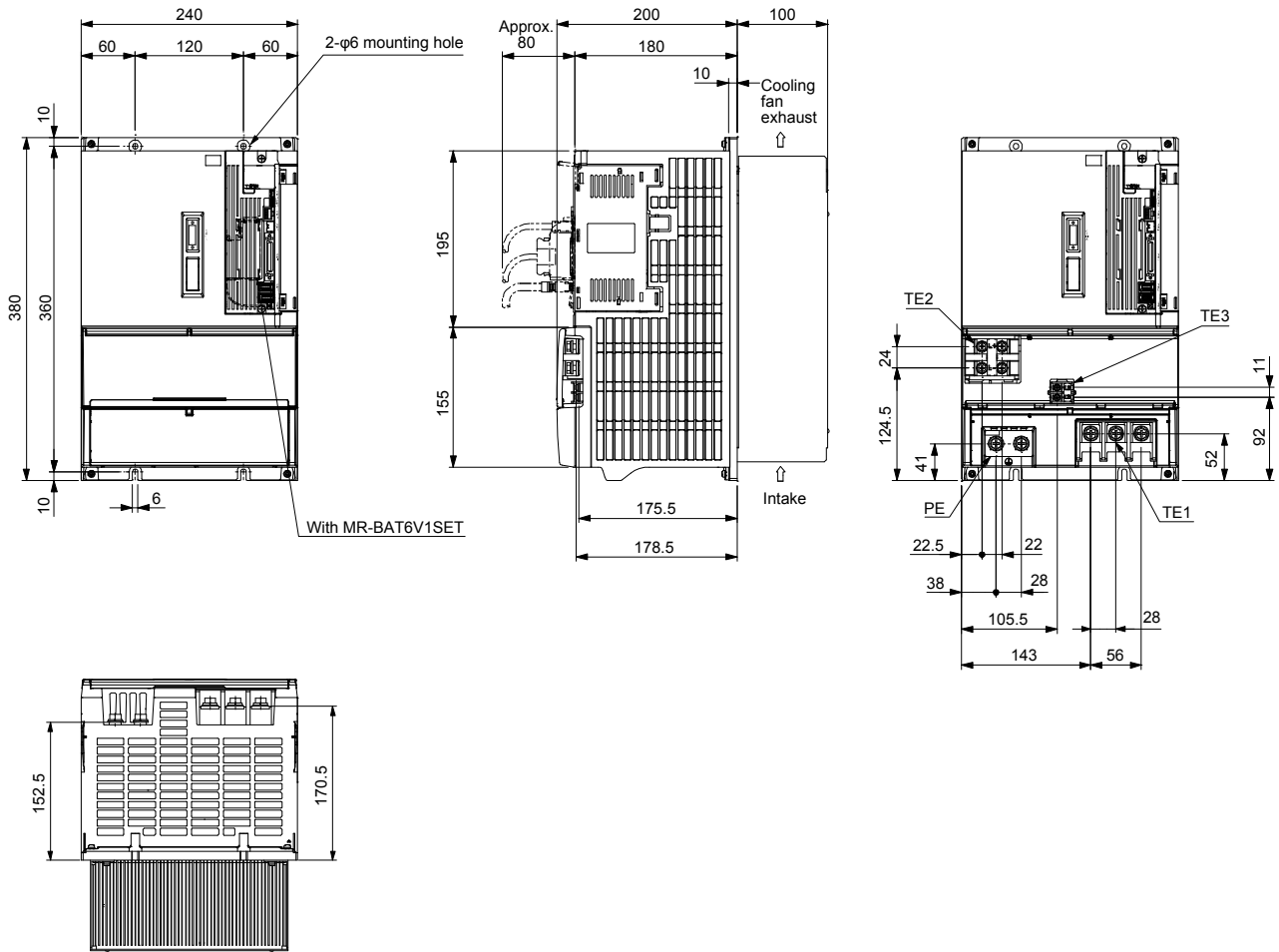

Mass: 16 [kg]

Mounting screw
Screw size: M5
Tightening torque: 3.24 [N•m]

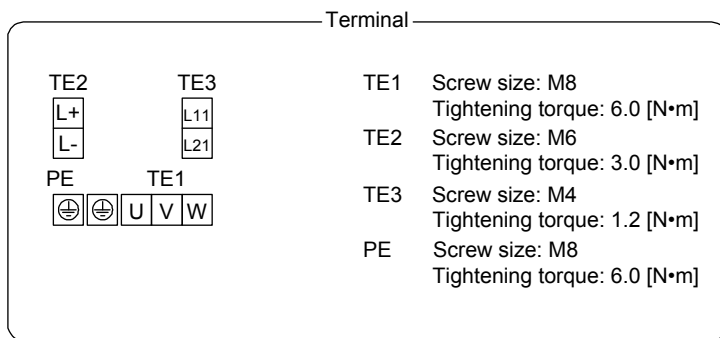

7. DIMENSIONS

7.2.2 MR-J4-DU_B_(-RJ)

POINT

● Only MR-J4-DU_B_-RJ is shown for dimensions. MR-J4-DU_B_ does not have CN2L connector. The dimensions of MR-J4-DU_B_ are the same as those of MR-J4-DU_B_-RJ except CN2L connector.

(1) MR-J4-DU30KB(-RJ)/MR-J4-DU37KB(-RJ)/MR-J4-DU45KB4(-RJ)/MR-J4-DU55KB4(-RJ)

[Unit: mm]

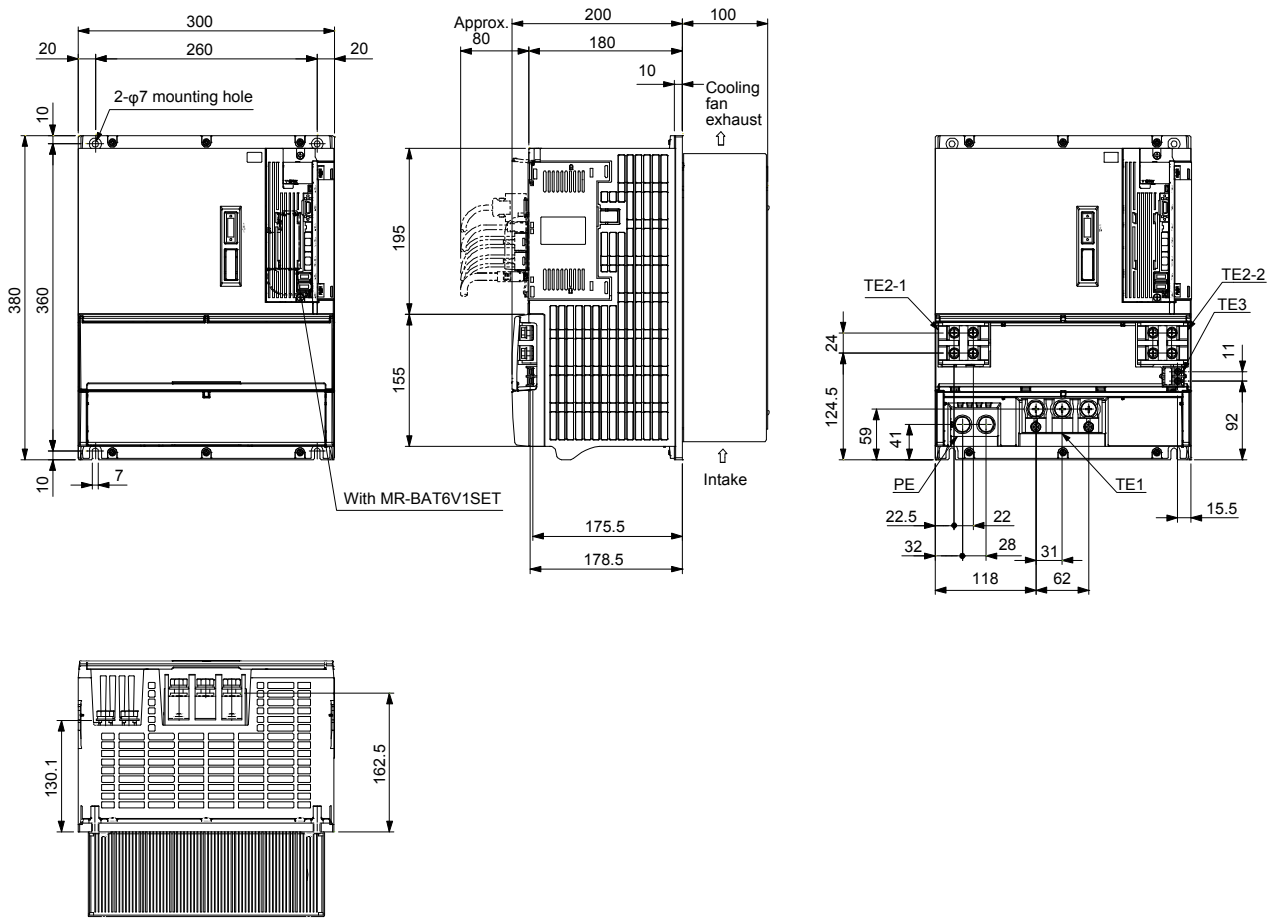

Mass: 21 [kg]

Terminal		
TE2-1	TE2-2	TE1
L+	L+	Screw size: M10
L-	L-	Tightening torque: 12.0 [N•m]
	TE3	TE2-1
	L11	Screw size: M6
	L21	Tightening torque: 3.0 [N•m]
PE	TE1	TE2-2
⊕ ⊖	U V W	Screw size: M6
		Tightening torque: 3.0 [N•m]
		TE3
		Screw size: M4
		Tightening torque: 1.2 [N•m]
		PE
		Screw size: M10
		Tightening torque: 12.0 [N•m]

Mounting screw
Screw size: M6
Tightening torque: 5.49 [N•m]

7. DIMENSIONS

(2) MR-J4-DU30KB4(-RJ)/MR-J4-DU37KB4(-RJ)

[Unit: mm]

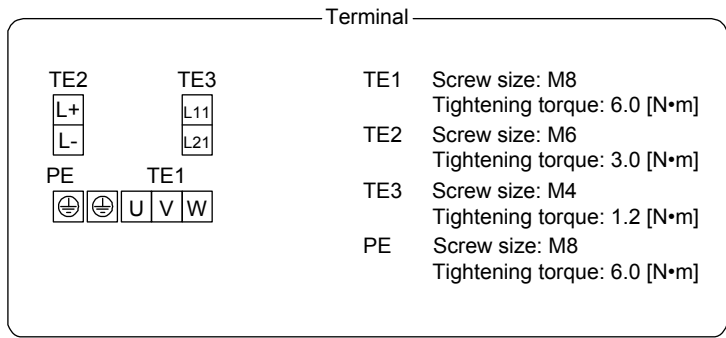
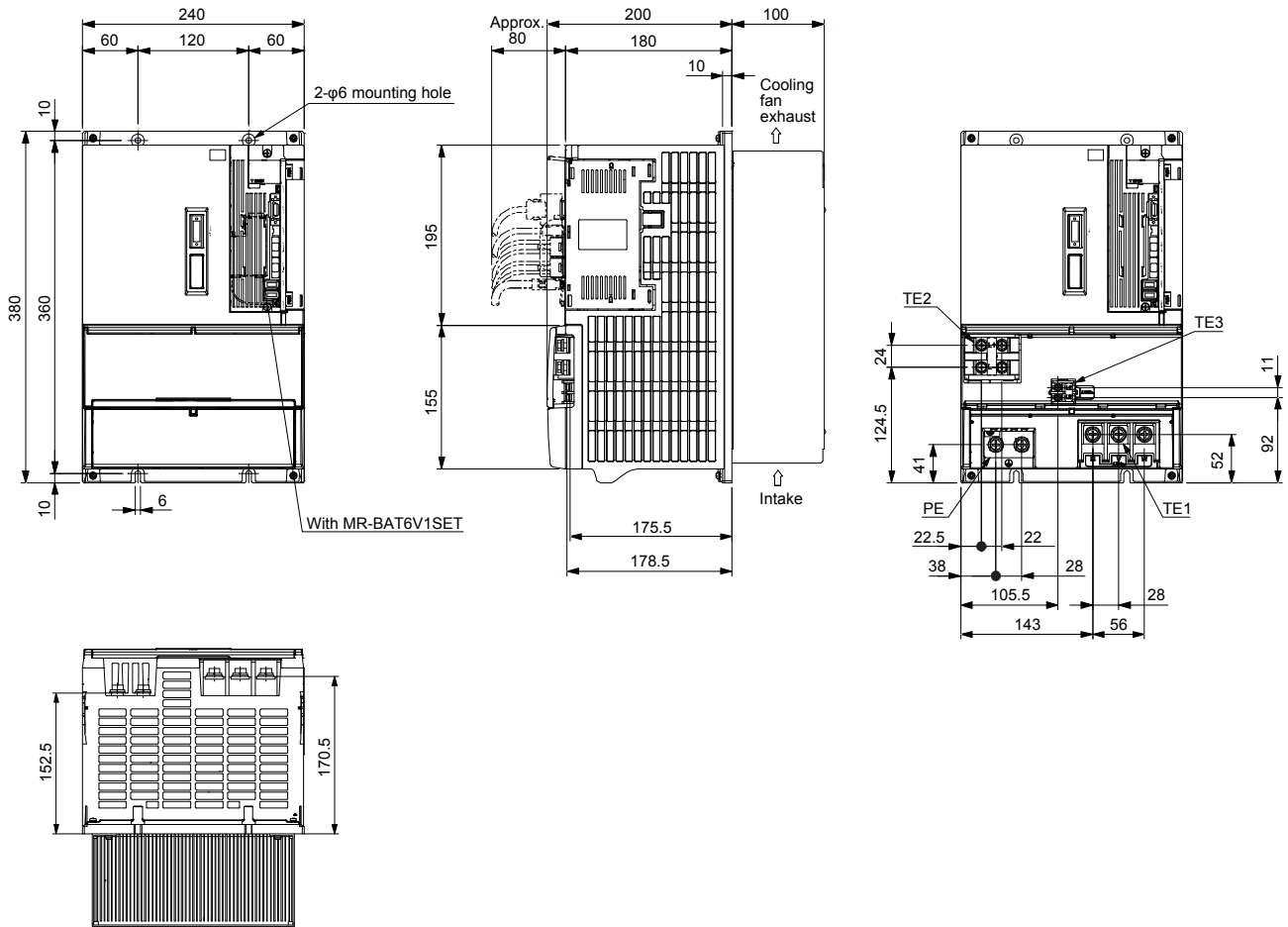

Mass: 16 [kg]
 Mounting screw
 Screw size: M5
 Tightening torque: 3.24 [N·m]

8. CHARACTERISTICS

8. CHARACTERISTICS

The following items are the same as those of MR-J4-_-(-RJ). For details of the items, refer to each chapter/section of the detailed explanation field. "MR-J4- _A_" means "MR-J4- _A_-(-RJ) Servo Amplifier Instruction Manual". "MR-J4- _B_" means "MR-J4- _B_-(-RJ) Servo Amplifier Instruction Manual".

Model	Item	Detailed explanation
MR-J4-DU_A_-(-RJ)	Cable bending life	MR-J4- _A_ section 10.4
MR-J4-DU_B_-(-RJ)	Cable bending life	MR-J4- _B_ section 10.4

8.1 Overload protection characteristics

8.1.1 Converter unit

An electronic thermal is built in the converter unit to protect the converter unit from overloads. [AL. 50 Overload 1] occurs if overload operation performed is above the electronic thermal protection curve shown in fig. 8.1. [AL. 51 Overload 2] occurs if the maximum current is applied continuously for several seconds due to machine collision, etc. Use the equipment on the left-side area of the graph.

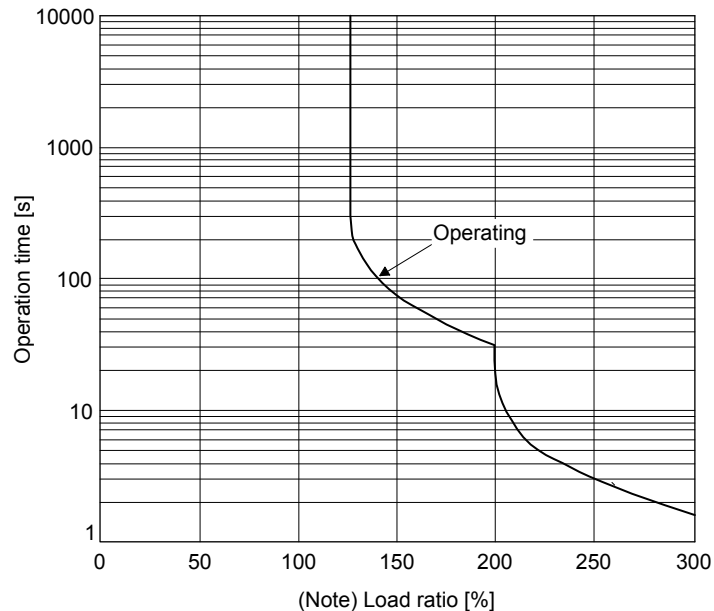

Note. Load ratio 100% indicates the rated output of the converter unit. Refer to section 1.2.1 for rated output.

Fig. 8.1 Electronic thermal protection characteristics

8. CHARACTERISTICS

8.1.2 Drive unit

An electronic thermal is built in the drive unit to protect the servo motor, drive unit and servo motor power wires from overloads.

[AL. 50 Overload 1] occurs if overload operation performed is above the electronic thermal protection curve shown in fig. 8.2. [AL. 51 Overload 2] occurs if the maximum current is applied continuously for several seconds due to machine collision, etc. Use the equipment on the left-side area of the continuous or broken line in the graph.

For the system where the unbalanced torque occurs, such as a vertical axis system, the unbalanced torque of the machine should be kept at 70% or lower of the motor's rated torque.

The drive unit has the servo motor overload protective function. (The servo motor overload current (full load current) is set on the basis of 120% rated current of the drive unit.)

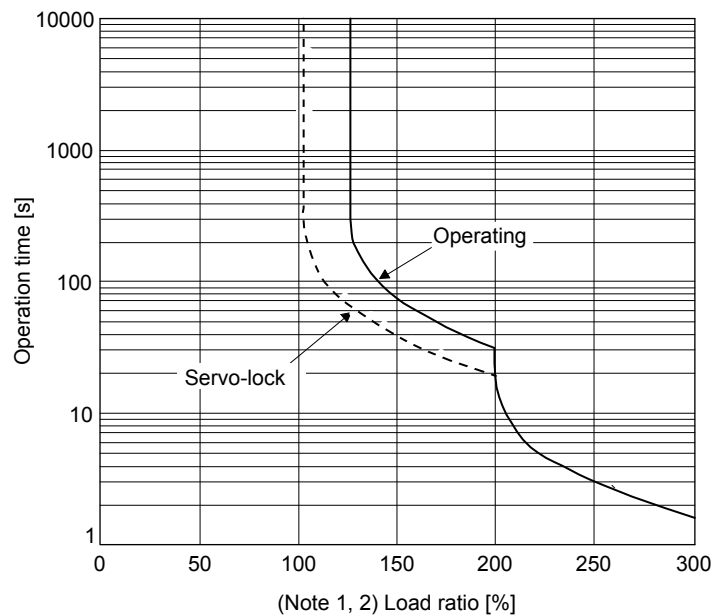

- Note 1. If operation that generates torque more than 100% of the rating is performed with an abnormally high frequency in a servo motor stop status (servo-lock status) or in a 30 r/min or less low-speed operation status, the drive unit may malfunction regardless of the electronic thermal protection.
- Note 2. Load ratio 100% indicates the rated output of the drive unit. Refer to section 1.2.2 for rated output.

Fig. 8.2 Electronic thermal protection characteristics

8. CHARACTERISTICS

8.2 Power supply capacity and generated loss

(1) Generated heat of the converter unit/drive unit

Table 8.1 indicates the generated loss and power supply capacity under rated load per combination of the converter unit and drive unit. When the servo motors are run at less than the rated speed, the power supply equipment capacity is lower than the value in the table but the heat generated does not change. Since the servo motor requires 2 times to 2.5 times greater instantaneous power for acceleration, use the power supply which ensures that the voltage lies within the permissible voltage fluctuation at the main circuit power supply terminals (L1, L2, and L3) of the converter unit. The power supply equipment capacity changes with the power supply impedance.

The actually generated heat falls within the ranges at rated output and at servo-off according to the frequencies of use during operation. When designing an enclosed cabinet, use the values in the table, considering the worst operating conditions. The generated heat in table 8.1 does not include heat produced during regeneration.

Table 8.1 Power supply capacity and generated heat per servo motor at rated output

Converter unit	Drive unit	Servo motor	Power supply capacity [kVA]		(Note) Drive unit-generated heat [W]			Area required for heat dissipation [m ²]
			Power factor improving DC reactor is not used	Power factor improving DC reactor is used	At rated output	At rated output [Generated heat in the cabinet when cooled outside the cabinet]	With servo-off	
MR-CR55K	MR-J4-DU30K_(-RJ)	HG-JR30K1 HG-JR30K1M	48	40	1350 (900 + 450)	470	60 (30 + 30)	31.0
	MR-J4-DU37K_(-RJ)	HG-JR37K1 HG-JR37K1M	59	49	1550 (1000 + 550)	550		36.6
MR-CR55K4	MR-J4-DU30K_4(-RJ)	HG-JR30K14 HG-JR30K1M4	48	40	1070 (790 + 280)	390		25.8
	MR-J4-DU37K_4(-RJ)	HG-JR37K14 HG-JR37K1M4	59	49	1252 (910 + 342)	470		30.8
	MR-J4-DU45K_4(-RJ)	HG-JR45K1M4	71	59	1580 (1110 + 470)	550	42.4	
	MR-J4-DU55K_4(-RJ)	HG-JR55K1M4	87	72	1940 (1440 + 500)	650	43.0	

Note. The heat generated by the drive unit is indicated in the left term within the parentheses, and the heat generated by the converter unit in the right term.

8. CHARACTERISTICS

(2) Heat dissipation area for an enclosed type cabinet

The enclosed type cabinet (hereafter called the cabinet) which will contain the converter unit and drive unit should be designed to ensure that its temperature rise is within +10 °C at the ambient temperature of 40 °C. (With an approximately 5 °C safety margin, the system should operate within a maximum 55 °C limit.) The necessary cabinet heat dissipation area can be calculated by equation 8.1.

$$A = \frac{P}{K \cdot \Delta T} \dots\dots\dots (8.1)$$

A: Heat dissipation area [m²]

P: Loss generated in the cabinet [W]

ΔT: Difference between internal and ambient temperatures [°C]

K: Heat dissipation coefficient [5 to 6]

When calculating the heat dissipation area with equation 8.1, assume that P is the sum of all losses generated in the cabinet. Refer to table 8.1 for the generated heat of the converter unit/drive unit. "A" indicates the effective area for heat dissipation, but if the cabinet is directly installed on an insulated wall, that extra amount must be added to the cabinet's surface area. The required heat dissipation area will vary with the conditions in the cabinet. If convection in the cabinet is poor and heat builds up, effective heat dissipation will not be possible. Therefore, arrangement of the equipment in the cabinet and the use of a cooling fan should be considered. Table 8.1 lists the cabinet dissipation area (guideline) when the converter unit and drive unit are operated at the ambient temperature of 40 °C under rated load.

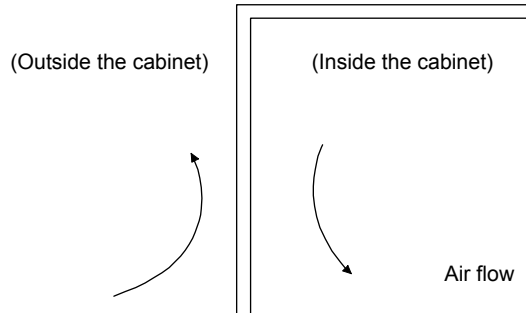

Fig. 8.3 Temperature distribution in an enclosed type cabinet

When air flows along the outer wall of the cabinet, effective heat exchange will be possible, because the temperature slope inside and outside the cabinet will be steeper.

8. CHARACTERISTICS

8.3 Dynamic brake characteristics

POINT
● Do not use dynamic brake to stop in a normal operation as it is the function to stop in emergency.
● For a machine operating at the recommended load to motor inertia ratio or less, the estimated number of usage times of the dynamic brake is 1000 times while the machine decelerates from the rated speed to a stop once in 10 minutes.
● Be sure to enable EM1 (Forced stop 1) after servo motor stops when using EM1 (Forced stop 1) frequently in other than emergency.
● Servo motors for MR-J4 may have the different coasting distance from that of the previous model.

8.3.1 Dynamic brake operation

(1) Calculation of coasting distance

Fig. 8.4 shows the pattern in which the servo motor comes to a stop when the dynamic brake is operated. Use equation 8.2 to calculate an approximate coasting distance to a stop. The dynamic brake time constant τ varies with the servo motor and machine operation speeds. (Refer to (2) of this section.) A working part generally has a friction force. Therefore, actual coasting distance will be shorter than a maximum coasting distance calculated with the following equation.

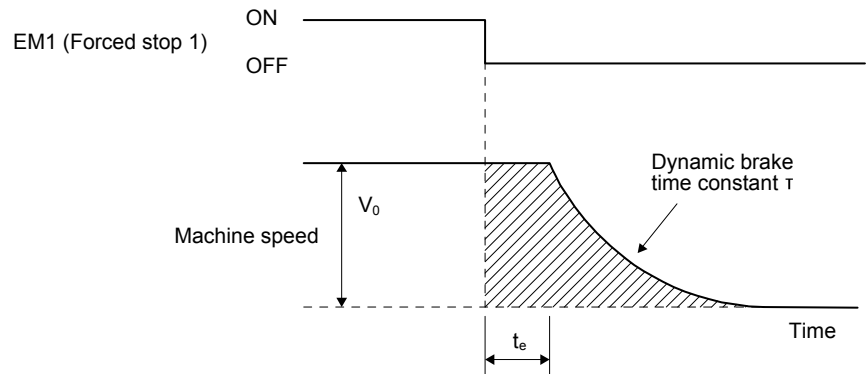

Fig. 8.4 Dynamic brake operation diagram

$$L_{\max} = \frac{V_0}{60} \cdot \left\{ t_e + \tau \left(1 + \frac{J_L}{J_M} \right) \right\} \dots\dots\dots (8.2)$$

- L_{\max} : Maximum coasting distance [mm]
 - V_0 : Machine's fast feed speed [mm/min]
 - J_M : Moment of inertia of the servo motor [$\times 10^{-4}$ kg·m²]
 - J_L : Load moment of inertia converted into equivalent value on servo motor shaft [$\times 10^{-4}$ kg·m²]
 - τ : Dynamic brake time constant [s]
 - t_e : Delay time of control section [s]
- There is delay caused by magnetic contactor built into the external dynamic brake (about 50 ms) and delay caused by the external relay.

8. CHARACTERISTICS

(2) Dynamic brake time constant

The following shows necessary dynamic brake time constant τ for equation 8.2.

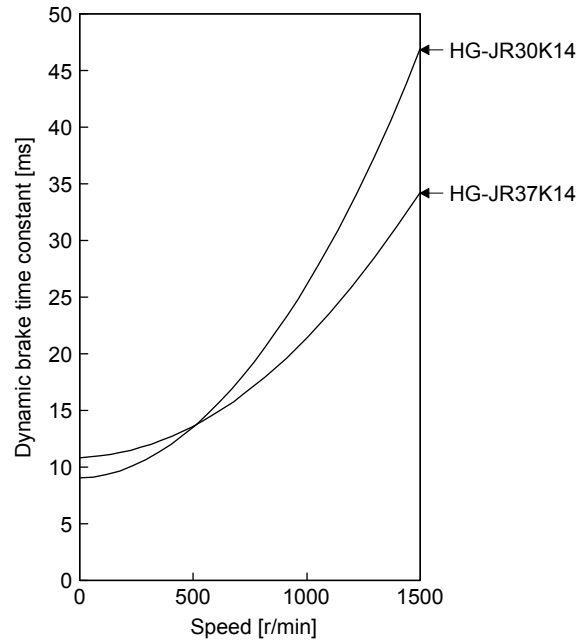
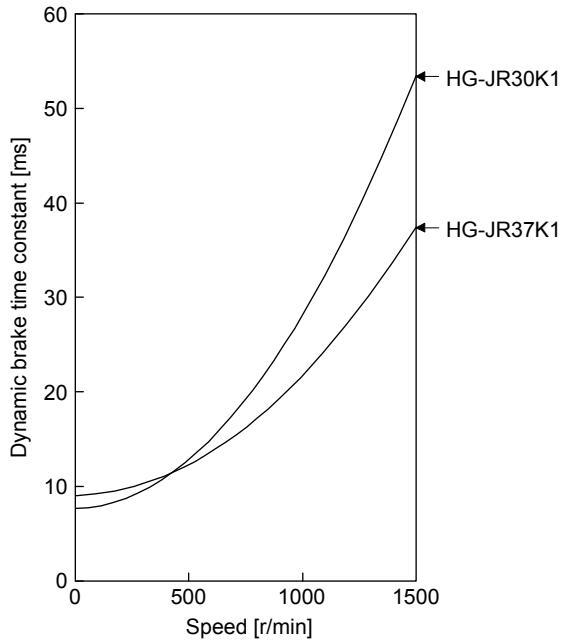

HG-JR1000 r/min series

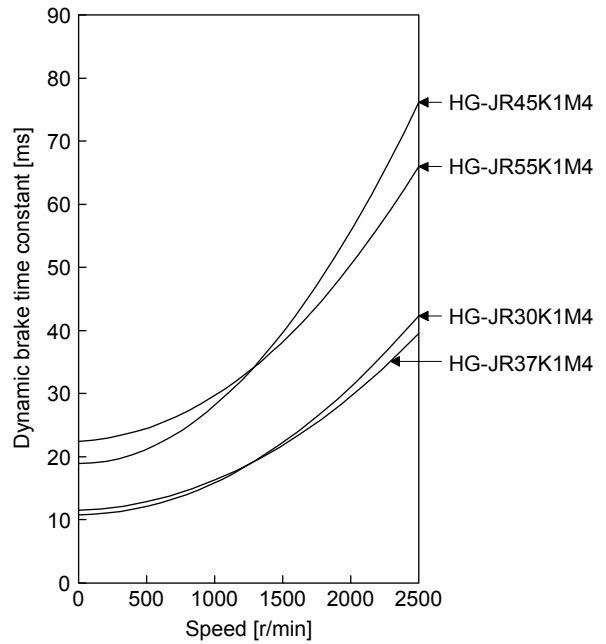
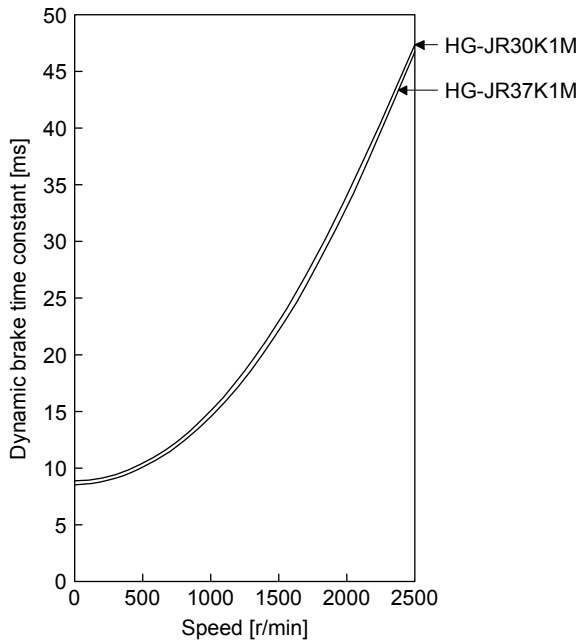

HG-JR1500 r/min series

8. CHARACTERISTICS

8.3.2 Permissible load to motor inertia when the dynamic brake is used

Use the dynamic brake under the load to motor inertia ratio indicated in the following table. If the ratio is higher than this value, the dynamic brake may burn. If there is a possibility that the ratio may exceed the value, contact your local sales office.

The values of the permissible load to motor inertia ratio in the table are the values at the maximum rotation speed of the servo motor. The value in the parenthesis shows the value at the rated speed.

Servo motor	Load to motor inertia ratio [multiplier]
HG-JR30K1	10
HG-JR37K1	
HG-JR30K14	
HG-JR37K14	
HG-JR30K1M	
HG-JR37K1M	
HG-JR30K1M4	
HG-JR37K1M4	
HG-JR45K1M4	8 (10)
HG-JR55K1M4	7 (10)

8. CHARACTERISTICS

8.4 Inrush currents at power-on of main circuit/control circuit

POINT
<ul style="list-style-type: none"> ● The inrush current values can change depending on frequency of turning on/off the power and ambient temperature.

Since large inrush currents flow in the power supplies, always use molded-case circuit breakers and magnetic contactors. (Refer to section 9.5.)

When circuit protectors are used, it is recommended that the inertia delay type, which is not tripped by an inrush current, be used.

(1) 200 V class

The following table indicates the inrush currents (reference data) that will flow when 240 V AC is applied at the power supply capacity of 2500 kVA and the wiring length of 1 m.

(a) Converter unit

Converter unit	Inrush currents (A_{0-P})	
	Main circuit power supply (L1, L2, and L3)	Control circuit power supply (L11 and L21)
MR-CR55K	154 A (Attenuated to approx. 20 A in 150 ms)	31 A (attenuated to approx. 2 A in 60 ms)

(b) Drive unit

Drive unit	Inrush currents (A_{0-P})
	Control circuit power supply (L11 and L21)
MR-J4-DU30K_(-RJ)	31 A (attenuated to approx. 2 A in 60 ms)
MR-J4-DU37K_(-RJ)	

(2) 400 V class

The following table indicates the inrush currents (reference data) that will flow when 480 V AC is applied at the power supply capacity of 2500 kVA and the wiring length of 1 m.

(a) Converter unit

Converter unit	Inrush currents (A_{0-P})	
	Main circuit power supply (L1, L2, and L3)	Control circuit power supply (L11 and L21)
MR-CR55K4	305 A (attenuated to approx. 20 A in 70 ms)	27 A (attenuated to approx. 2 A in 45 ms)

(b) Drive unit

Drive unit	Inrush currents (A_{0-P})
	Control circuit power supply (L11 and L21)
MR-J4-DU30K_4(-RJ)	27 A (attenuated to approx. 2 A in 45 ms)
MR-J4-DU37K_4(-RJ)	
MR-J4-DU45K_4(-RJ)	
MR-J4-DU55K_4(-RJ)	

9. OPTIONS AND PERIPHERAL EQUIPMENT

9. OPTIONS AND PERIPHERAL EQUIPMENT

 WARNING	<ul style="list-style-type: none"> ● Before connecting any option or peripheral equipment, turn off the power and wait for 20 minutes or more until the charge lamp turns off. Then, confirm that the voltage between L+ and L- is safe with a voltage tester and others. Otherwise, an electric shock may occur. In addition, always confirm whether the charge lamp is off or not from the front of the converter unit.
--	--

 CAUTION	<ul style="list-style-type: none"> ● Use the specified peripheral equipment and options to prevent a malfunction or a fire.
--	--

POINT	<ul style="list-style-type: none"> ● We recommend using HIV wires to wire the converter units, drive units, options, and peripheral equipment. Therefore, the recommended wire sizes may differ from those of the used wires for the previous converter units, drive units and others.
--------------	---

The following items are the same as those of MR-J4-_-(-RJ). For details of the items, refer to each chapter/section of the detailed explanation field. "MR-J4-_A_" means "MR-J4-_A_(-RJ) Servo Amplifier Instruction Manual". "MR-J4-_B_" means "MR-J4-_B_(-RJ) Servo Amplifier Instruction Manual".

Model	Item	Detailed explanation
MR-J4-DU_A_(-RJ)	Junction terminal block MR-TB50	MR-J4-_A_ section 11.6
	MR Configurator2	MR-J4-_A_ section 11.7
	Battery	MR-J4-_A_ section 11.8
	Relay (recommended)	MR-J4-_A_ section 11.13
MR-J4-DU_B_(-RJ)	Junction terminal block PS7DW-20V14B-F (recommended)	MR-J4-_B_ section 11.6
	MR Configurator2	MR-J4-_B_ section 11.7
	Battery	MR-J4-_B_ section 11.8
	Relay (recommended)	MR-J4-_B_ section 11.13

9. OPTIONS AND PERIPHERAL EQUIPMENT

9.1 Cable/connector sets

9.1.1 Combinations of cable/connector sets

Parts other than the following cable/connector sets are the same as those of MR-J4-_-(-RJ). When you use MR-J4-DU_A_-(-RJ), refer to section 11.1 of "MR-J4-_A_-(-RJ) Servo Amplifier Instruction Manual". When you use MR-J4-DU_B_-(-RJ), refer to section 11.1 of "MR-J4-_B_-(-RJ) Servo Amplifier Instruction Manual".

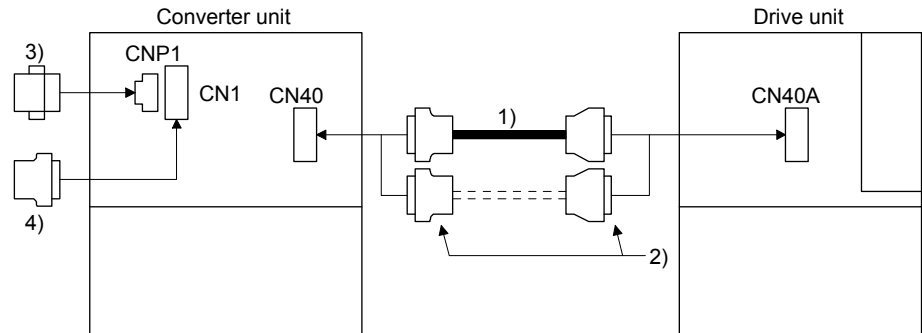

No.	Product name	Model	Description		Application
1)	Protection coordination cable	MR-J3CDL05M (Refer to section 9.1.2.)	Connector: 10120-3000PE Shell kit: 10320-52F0-008 (3M or equivalent)	Connector: PCR-S20FS+ Case: PCR-LS20LA1 (Honda Tsushin Kogyo)	
2)	Connector set	MR-J2CN1-A (Refer to section 9.1.2.)	Connector: 10120-3000PE Shell kit: 10320-52F0-008 (3M or equivalent)	Connector: PCR-S20FS+ Shell kit: PCR-LS20LA1 (Honda Tsushin Kogyo)	
3)	Magnetic contactor wiring connector		Converter unit side connector (Phoenix Contact) Socket: GFKC 2,5/ 2-STF-7,62		Supplied with converter unit
4)	Digital I/O connector		Converter unit side connector (DDK) Connector: 17JE23090-02(D8A)K11-CG		

9. OPTIONS AND PERIPHERAL EQUIPMENT

9.1.2 MR-J3CDL05M (0.5 m) protection coordination cable

CAUTION ● Wire protection coordination cables correctly if they are fabricated. Otherwise, it may cause an unexpected operation.

The cable is used to connect a converter unit to a drive unit.

(1) Internal wiring diagram

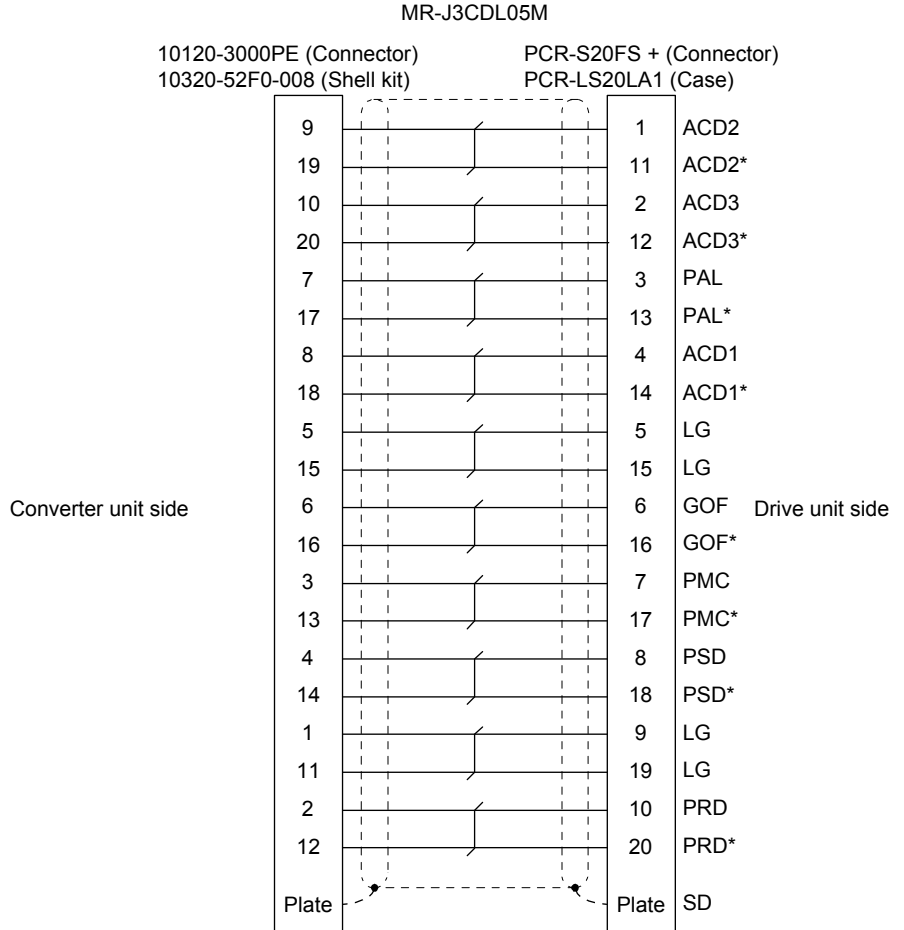

9. OPTIONS AND PERIPHERAL EQUIPMENT

(2) When fabricating a cable

When fabricating a cable, use MR-J2CN1-A connector set and the following recommended wire to fabricate it according to the wiring diagram in (1) of this section.

Model	Length [m]	Core size [mm ²]	Number of cores	Characteristics of one core			(Note 2) Cable OD [mm]	Wire model
				Structure [Wires/mm]	Conductor resistance [Ω/km]	(Note 1) Insulator OD d [mm]		
MR-J3CDL05M	0.5	0.08	20 (10 pairs)	7/0.127	222 or less	0.38	6.1	UL 20276 AWG#28 10pair (cream)

Note 1. The following shows the detail of d.

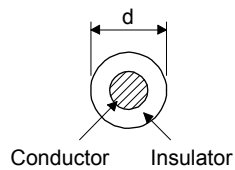

2. Standard OD. Maximum OD is about 10% greater.

9. OPTIONS AND PERIPHERAL EQUIPMENT

9.2 Regenerative option



CAUTION

● Do not use the converter unit and drive unit with the regenerative options other than the combinations specified below. Otherwise, it may cause a fire.

9.2.1 Combination and regenerative power

The regenerative power values in the table are the regenerative power of the resistor and are not the rated power.

Converter unit	Drive unit	Regenerative power [W]			
		MR-RB139 (1.3 Ω)	(Note 1) Three MR-RB137 (1.3 Ω) in parallel	MR-RB137-4 (4 Ω)	(Note 2) Three MR-RB13V-4 (4 Ω) in parallel
MR-CR55K	MR-J4-DU30K_(-RJ)	1300	3900		
	MR-J4-DU37K_(-RJ)				
MR-CR55K4	MR-J4-DU30K_4(-RJ)			1300	3900
	MR-J4-DU37K_4(-RJ)				
	MR-J4-DU45K_4(-RJ)				
	MR-J4-DU55K_4(-RJ)				

- Note
1. The resultant resistance of three options is 1.3 Ω.
 2. The resultant resistance of three options is 4 Ω.

9. OPTIONS AND PERIPHERAL EQUIPMENT

9.2.2 Selection of regenerative option

Use the following method when regeneration occurs continuously in vertical motion applications or when it is desired to make an in-depth selection of the regenerative option.

(1) Regenerative energy calculation

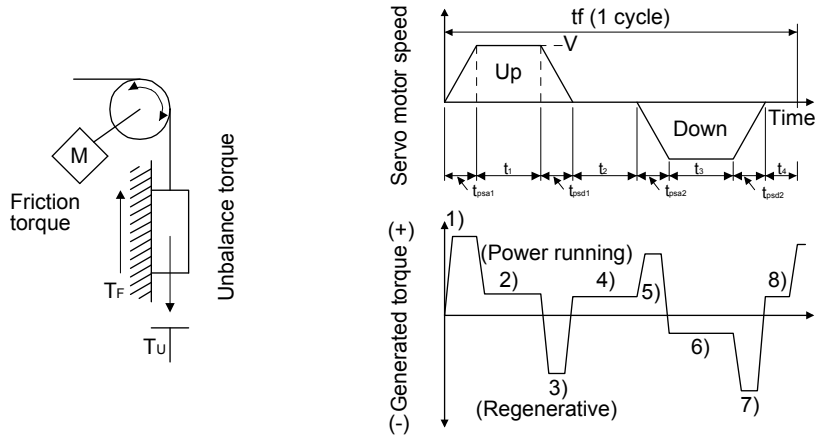

Formulas for calculating torque and energy in operation

Regenerative power	Torque applied to servo motor T [N·m]	Energy E [J]
1)	$T_1 = \frac{(J_L/\eta + J_M) \cdot V}{9.55 \cdot 10^4} \cdot \frac{1}{t_{psa1}} + T_U + T_F$	$E_1 = \frac{0.1047}{2} \cdot V \cdot T_1 \cdot t_{psa1}$
2)	$T_2 = T_U + T_F$	$E_2 = 0.1047 \cdot V \cdot T_2 \cdot t_1$
3)	$T_3 = \frac{-(J_L \cdot \eta + J_M) \cdot V}{9.55 \cdot 10^4} \cdot \frac{1}{t_{psa2}} + T_U + T_F$	$E_3 = \frac{0.1047}{2} \cdot V \cdot T_3 \cdot t_{psa2}$
4), 8)	$T_4, T_8 = T_U$	$E_4, E_8 \geq 0$ (No regeneration)
5)	$T_5 = \frac{(J_L/\eta + J_M) \cdot V}{9.55 \cdot 10^4} \cdot \frac{1}{t_{psd2}} - T_U + T_F$	$E_5 = \frac{0.1047}{2} \cdot V \cdot T_5 \cdot t_{psd2}$
6)	$T_6 = -T_U + T_F$	$E_6 = 0.1047 \cdot V \cdot T_6 \cdot t_3$
7)	$T_7 = \frac{-(J_L \cdot \eta + J_M) \cdot V}{9.55 \cdot 10^4} \cdot \frac{1}{t_{psd2}} - T_U + T_F$	$E_7 = \frac{0.1047}{2} \cdot V \cdot T_7 \cdot t_{psd2}$

From the calculation results in 1) to 8), find the absolute value (Es) of the sum total of negative energies.

9. OPTIONS AND PERIPHERAL EQUIPMENT

(2) Regenerative loss of servo motor and drive unit

The following table lists the efficiencies and other data of the servo motor and drive unit in the regenerative mode.

Converter unit	Drive unit	Inverse efficiency [%]	Capacitor charging [J]
MR-CR55K	MR-J4-DU30K_(-RJ)	90	450
	MR-J4-DU37K_(-RJ)		
MR-CR55K4	MR-J4-DU30K_4(-RJ)		
	MR-J4-DU37K_4(-RJ)		
	MR-J4-DU45K_4(-RJ)		
	MR-J4-DU55K_4(-RJ)		

Inverse efficiency (η): Efficiency including some efficiencies of the servo motor and drive unit when rated (regenerative) torque is generated at rated speed. Since the efficiency varies with the speed and generated torque, allow for about 10%.

Capacitor charging (E_c): Energy charged into the electrolytic capacitor in the converter unit

Subtract the capacitor charging from the result of multiplying the sum total of regenerative energies by the inverse efficiency to calculate the energy consumed by the regenerative option.

$$ER [J] = \eta \cdot E_s - E_c$$

Calculate the power consumption of the regenerative option on the basis of one-cycle operation period t_f [s] to select the necessary regenerative option.

$$PR [W] = ER/t_f$$

9.2.3 Parameter setting

POINT
<p>● The regenerative option cannot be connected to the drive unit. Always set [Pr. PA02] of the drive unit to "_ _ 0 0" (the regenerative option is not used).</p>

Set [Pr. PA01] of the converter unit according to the option to be used.

[Pr. PA01]			
0	0		

Regenerative option selection
 00: Regenerative option is not used.
 01: MR-RB139
 02: MR-RB137 (3 pcs.)
 13: MR-RB137-4
 14: MR-RB13V-4 (3 pcs.)

9. OPTIONS AND PERIPHERAL EQUIPMENT

9.2.4 Connection of regenerative option

POINT
● For the wire sizes used for wiring, refer to section 9.4.

Always supply the following power to a cooling fan.

Table 9.1 Cooling fan

Item	200 V class	400 V class
Model	MR-RB137/MR-RB139	MR-RB137-4/MR-RB13V-4
Voltage/Frequency	1-phase 198 V AC to 242 V AC, 50 Hz/60 Hz	1-phase 380 V AC to 480 V AC, 50 Hz/60 Hz
Power consumption [W]	20 (50 Hz)/18 (60 Hz)	20 (50 Hz)/18 (60 Hz)

The regenerative option generates heat of 100 °C higher than the ambient temperature. Fully consider heat dissipation, installation position, wires used, etc. before installing the option. For wiring, use flame-resistant wires or make the wires flame-resistant and keep them away from the regenerative option. The G3 and G4 terminals act as a thermal protector. Between G3 and G4 is opened when the regenerative option overheats abnormally.

Always use twisted cables of max. 5 m length for connection with the converter unit.

(1) MR-RB139/MR-RB137-4

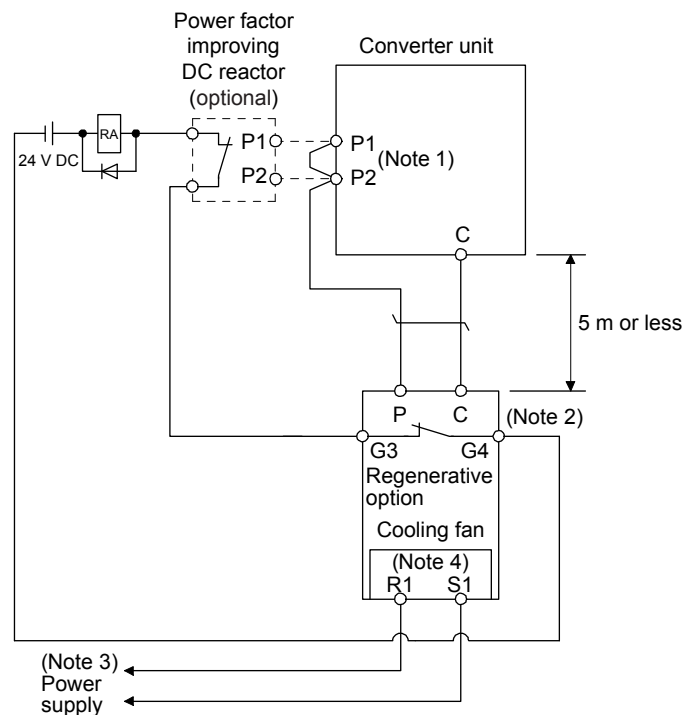

- Note 1. When using the power factor improving DC reactor, remove the short bar across P1 and P2.
- Note 2. G3-G4 contact specifications
 Maximum voltage: 120 V AC/DC
 Maximum current: 0.5 A/4.8 V DC
 Maximum capacity: 2.4 VA
- Note 3. For specifications of cooling fan power supply, refer to table 9.1.
- Note 4. For MR-RB137-4, "R1" is "R400" and "S1" is "S400".

9. OPTIONS AND PERIPHERAL EQUIPMENT

(2) MR-RB137/MR-RB13V-4

POINT
<p>● Three of MR-RB137 or MR-RB13V-4 are required per converter unit. Please purchase three of MR-RB137 or MR-RB13V-4.</p>

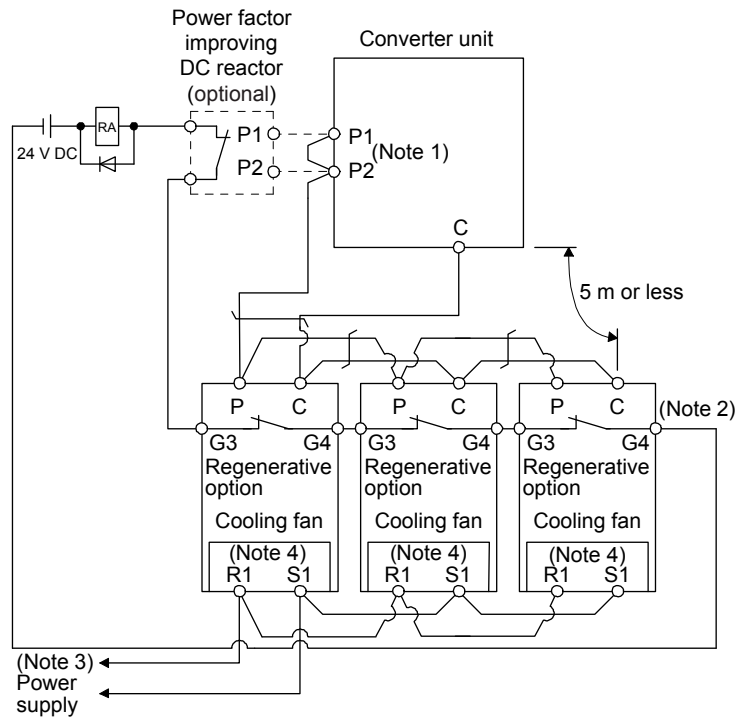

- Note 1. When using the power factor improving DC reactor, remove the short bar across P1 and P2.
- Note 2. G3-G4 contact specifications
 Maximum voltage: 120 V AC/DC
 Maximum current: 0.5 A/4.8 V DC
 Maximum capacity: 2.4 VA
- Note 3. For specifications of cooling fan power supply, refer to table 9.1.
- Note 4. For MR-RB13V-4, "R1" is "R400" and "S1" is "S400".

9. OPTIONS AND PERIPHERAL EQUIPMENT

9.2.5 Dimensions

[Unit: mm]

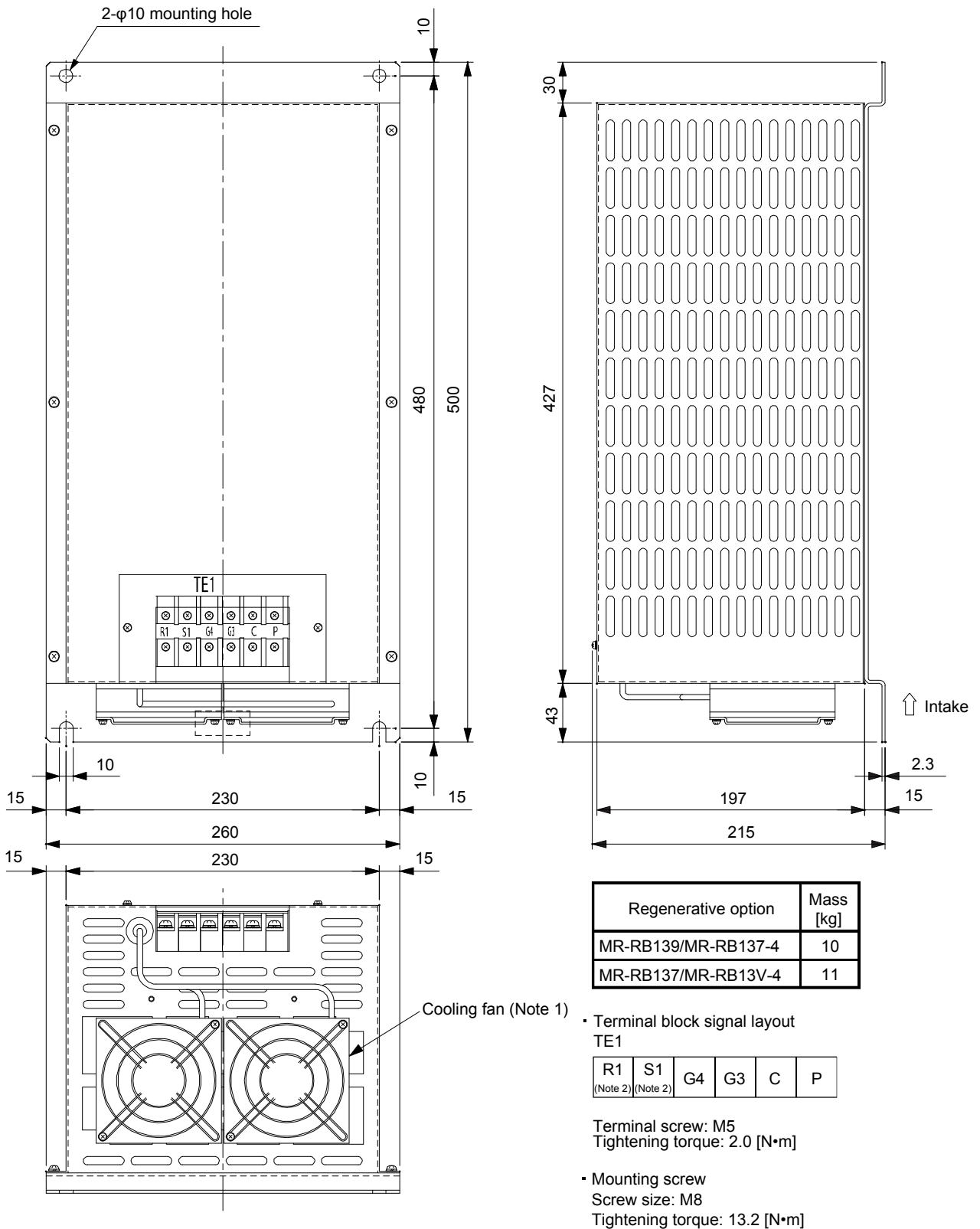

- Note 1. One cooling fan for MR-RB137-4/MR-RB13V-4.
 2. For MR-RB137-4/MR-RB13V-4, "R1" is "R400" and "S1" is "S400".

9. OPTIONS AND PERIPHERAL EQUIPMENT

9.3 External dynamic brake

CAUTION

- Use an external dynamic brake for the drive unit. Failure to do so will cause an accident because the servo motor does not stop immediately but coasts at an alarm occurrence for which the servo motor does not decelerate to stop. Ensure the safety in the entire equipment. For alarms for which the servo motor does not decelerate to stop, refer to chapter 6.
- The external dynamic brake cannot be used for compliance with SEMI-F47 standard. Do not assign DB (Dynamic brake interlock). Doing so will cause the drive unit to become servo-off when an instantaneous power failure occurs.

POINT

- For drive units, EM2 has the same function as EM1 in the torque control mode.
- Configure a sequence which switches off the magnetic contactor of the external dynamic brake after (or as soon as) SON (Servo-on) has been turned off at a power failure or a malfunction.
- For the external braking time taken when the dynamic brake is operated, refer to section 8.3.
- The external dynamic brake is rated for a short duration. Do not use it very frequently.
- The specifications of the input power supply for external dynamic brake are the same as those of the converter unit control circuit power supply.
- When an alarm, [AL. E6 Servo forced stop warning], or [AL. E7 Controller forced stop warning] occurs, or the power is turned off, the external dynamic brake will operate. Do not use external dynamic brake to stop in a normal operation as it is the function to stop in emergency.
- For a machine operating at the recommended load to motor inertia ratio or less, the estimated number of usage times of the external dynamic brake is 1000 times while the machine decelerates from the rated speed to a stop once in 10 minutes.
- Be sure to enable EM1 (Forced stop 1) after servo motor stops when using EM1 (Forced stop 1) frequently in other than emergency.

9.3.1 Selection of external dynamic brake

The external dynamic brake is designed to bring the servo motor to a sudden stop when a power failure occurs or the protective circuit is activated. For MR-J4-DU_A_(-RJ) drive unit, assign DB (Dynamic brake interlock) to any of CN1-22 to CN1-25, CN1-49, CN1-13 and CN1-14 pins in [Pr. PD23] to [Pr. PD26], [Pr. PD28] and [Pr. PD47]. For MR-J4-DU_B_(-RJ) drive unit, assign DB (Dynamic brake interlock) to any of CN3-9, CN3-13, and CN3-15 pins in [Pr. PD07] to [Pr. PD09].

Converter unit	Drive unit	External dynamic brake
MR-CR55K	MR-J4-DU30K_(-RJ)	DBU-37K-R1
	MR-J4-DU37K_(-RJ)	
MR-CR55K4	MR-J4-DU30K_4(-RJ)	DBU-55K-4-R5
	MR-J4-DU37K_4(-RJ)	
	MR-J4-DU45K_4(-RJ)	
	MR-J4-DU55K_4(-RJ)	

9. OPTIONS AND PERIPHERAL EQUIPMENT

9.3.2 Connection example

Use the following wires to connect the dynamic brake.

Dynamic brake	Wire [mm ²] (Note)	
	Except U/V/W	U/V/W
DBU-37K-R1	2	14
DBU-55K-4-R5		

Note. Selection conditions of wire size are as follows.

Wire type: 600 V grade heat-resistant polyvinyl chloride insulated wire (HIV wire)

Construction condition: Single wire set in midair

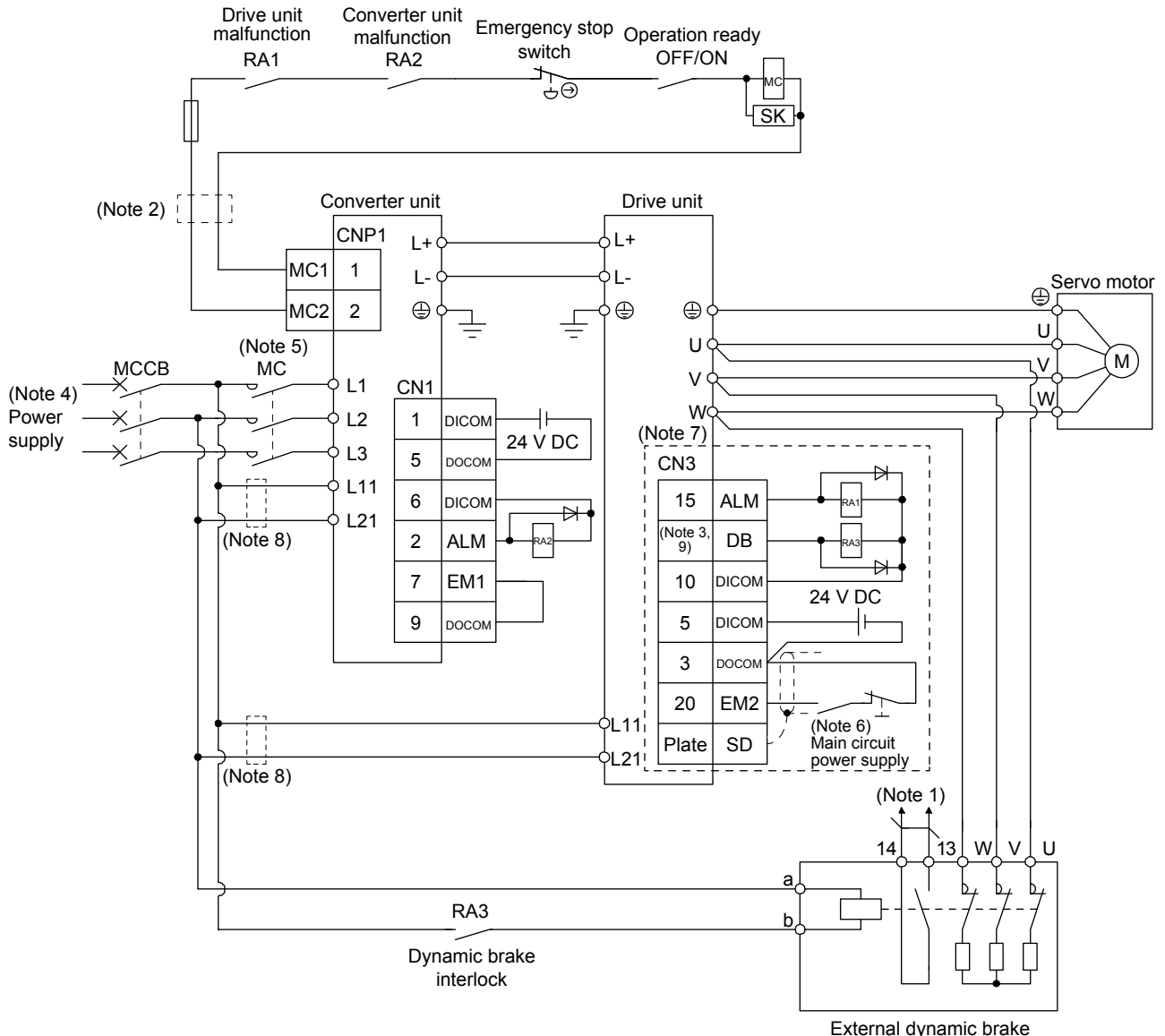

- Note
1. Terminals 13 and 14 are normally open contact outputs. If the dynamic brake is seized, terminals 13 and 14 will open. Therefore, configure an external sequence to prevent servo-on.
 2. Step-down transformer is required when coil voltage of the magnetic contactor is 200 V class, and the converter unit and the drive unit are 400 V class.
 3. Assign DB (Dynamic brake interlock) with the parameter.
 4. For the power supply specifications, refer to section 1.2.
 5. Depending on the main circuit voltage and operation pattern, bus voltage decreases, and that may cause the forced stop deceleration to shift to the dynamic brake deceleration. When dynamic brake deceleration is not required, slow the time to turn off the magnetic contactor.
 6. Turn off EM2 when the main power circuit power supply is off.
 7. The wiring is for MR-J4-DU_B_(-RJ). The connection for the interface of MR-J4-DU_(-RJ) is the same as in the case of MR-J4_(-RJ). Refer to each servo amplifier instruction manual.
 8. Install an overcurrent protection device (molded-case circuit breaker or fuse) to protect the branch circuit. (Refer to section 9.5.)
 9. The external dynamic brake cannot be used for compliance with SEMI-F47 standard. Do not assign DB (Dynamic brake interlock). Doing so will cause the drive unit to become servo-off when an instantaneous power failure occurs.

9. OPTIONS AND PERIPHERAL EQUIPMENT

9.3.3 Timing chart

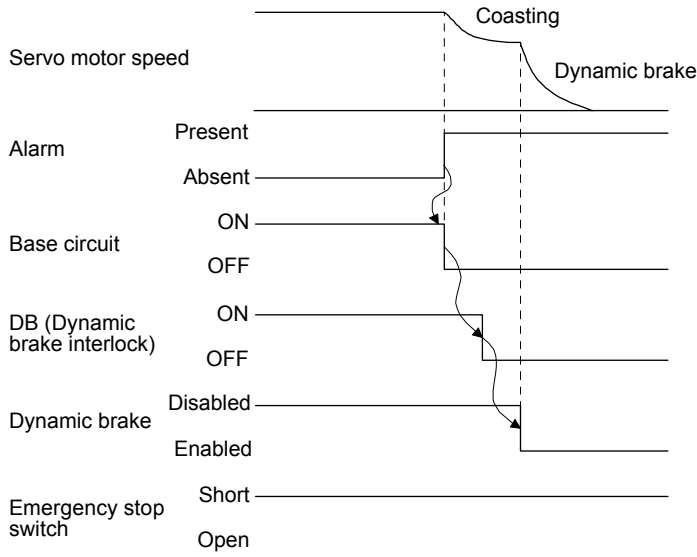

a. Timing chart at alarm occurrence

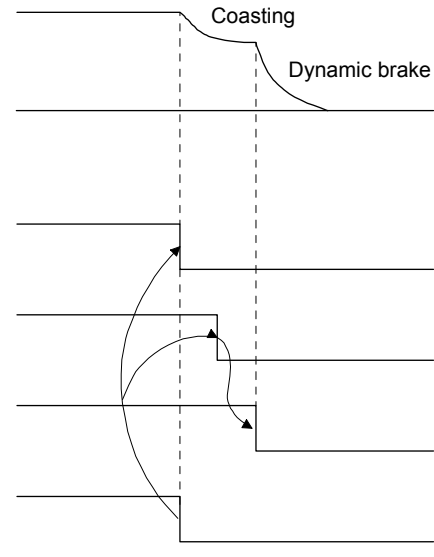

b. Timing chart at Emergency stop switch enabled

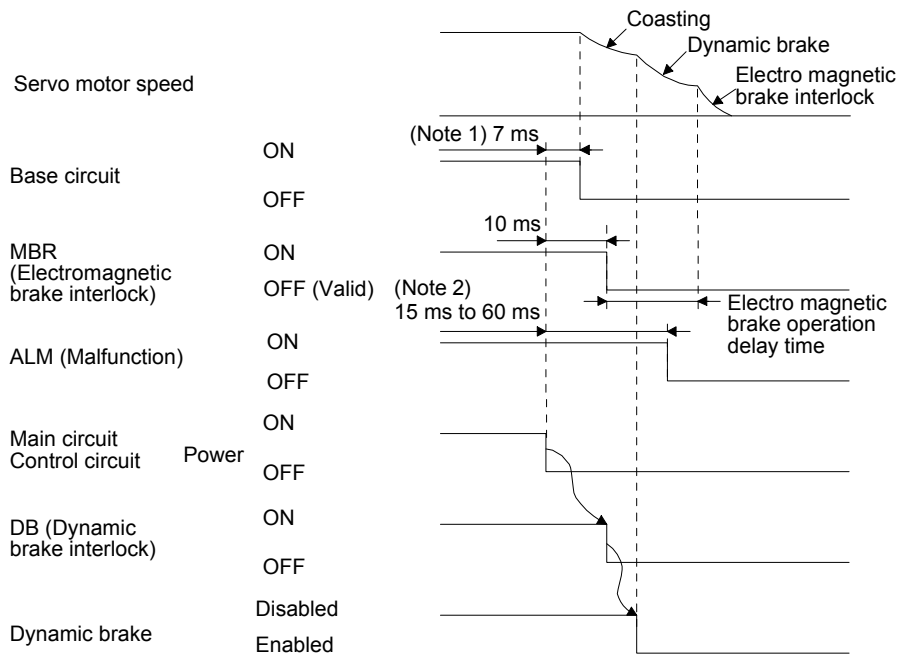

- Note 1. When powering off, DB (Dynamic brake interlock) will be turned off, and the base circuit is turned off earlier than usual before an output shortage occurs. (only when DB is assigned as an output signal)
- Note 2. Variable according to the operation status.

c. Timing chart when both of the main and control circuit power supply are off

9. OPTIONS AND PERIPHERAL EQUIPMENT

9.3.4 Dimensions

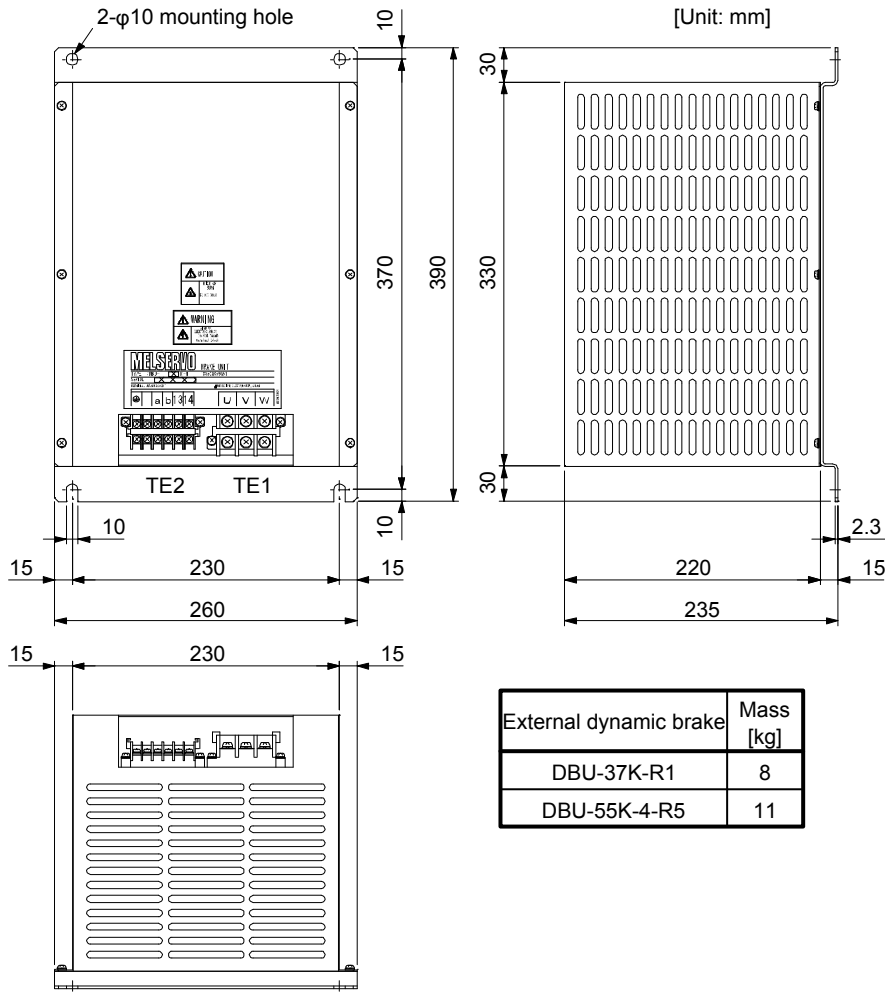

- Terminal block

TE

U	V	W
---	---	---

Screw size: M5

Tightening torque: 2.0 [N•m]

TE2

⊕		a	b	13	14
---	--	---	---	----	----

Screw size: M3.5

Tightening torque: 0.8 [N•m]

- Mounting screw

Screw size: M8

Tightening torque: 13.2 [N•m]

9. OPTIONS AND PERIPHERAL EQUIPMENT

9.4 Selection example of wires

POINT
<ul style="list-style-type: none"> ● To comply with the IEC/EN/UL/CSA standard, use the wires shown in appendix 2 for wiring. To comply with other standards, use a wire that is complied with each standard. ● Selection conditions of wire size are as follows. Construction condition: Single wire set in midair Wire length: 30 m or less

The following diagram shows the wires used for wiring. Use the wires given in this section or equivalent.

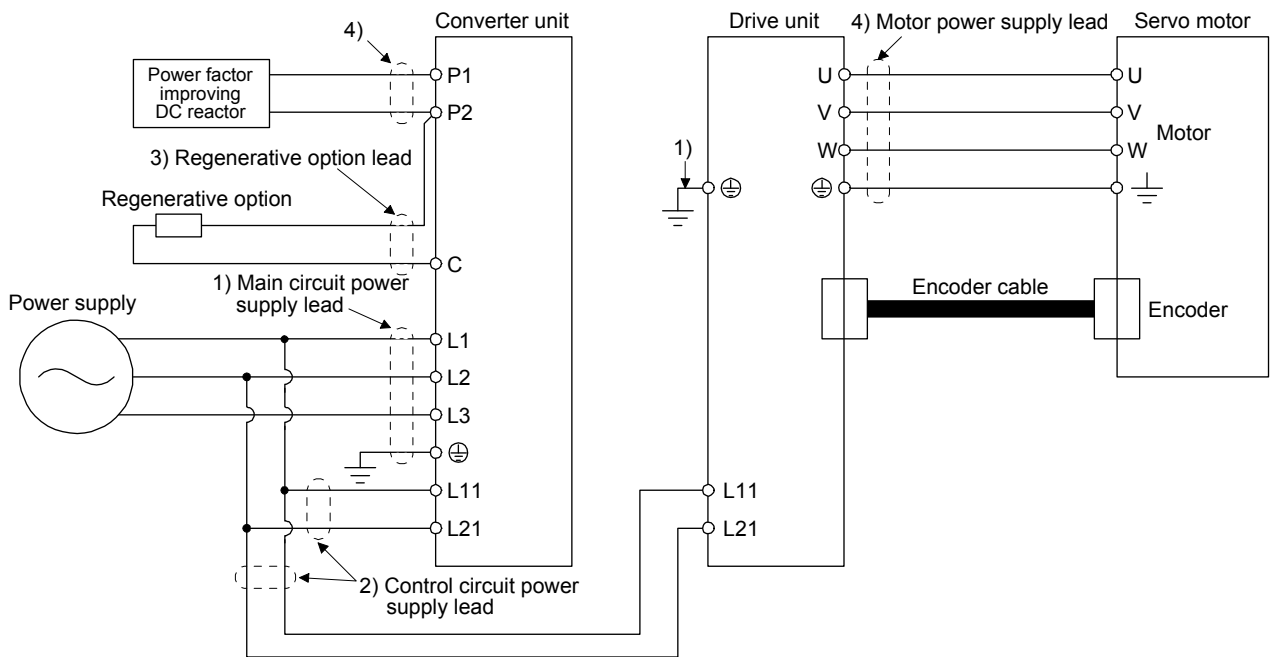

(1) Example of selecting the wire sizes

Use the 600 V grade heat-resistant polyvinyl chloride insulated wire (HIV wire) for wiring. The following shows the wire size selection example.

Table 9.2 Wire size selection example (HIV wire)

Converter unit (Note 2)	Drive unit (Note 2)	Wire [mm ²] (Note 1, 3)			
		1) L1/L2/L3/⊕	2) L11/L21	3) P2/C	4) U/V/W P1/P2/⊕
MR-CR55K	MR-J4-DU30K_(-RJ)	38 (AWG2): c	1.25 to 2 (AWG 16 to 14): g (Note 4)	5.5 (AWG10): a	60 (AWG2/0): d
	MR-J4-DU37K_(-RJ)	60 (AWG2/0): d			60 (AWG2/0): d
MR-CR55K4	MR-J4-DU30K_4(-RJ)	22 (AWG4): e			22 (AWG4): e
	MR-J4-DU37K_4(-RJ)	22 (AWG4): e			38 (AWG 2): f
	MR-J4-DU45K_4(-RJ)	38 (AWG2): c			38 (AWG2): c
	MR-J4-DU55K_4(-RJ)	38 (AWG2): c	38 (AWG2): c		

Note 1. Alphabets in the table indicate crimping tools. For crimp terminals and applicable tools, refer to (2) in this section.

Note 2. To connect these models to a terminal block, be sure to use the screws that come with the terminal block.

Note 3. Wires are selected based on the highest rated current among combining servo motors.

Note 4. Be sure to use the size of 2 mm² when corresponding to the IEC/EN/UL/CSA standard.

9. OPTIONS AND PERIPHERAL EQUIPMENT

(2) Selection example of crimp terminals

The following shows the selection example of crimp terminals for terminal blocks of the drive unit and converter unit when you use wires mentioned in (1) of this section.

Symbol	Drive unit/converter unit-side crimp terminal				Manufacturer
	(Note 2) Crimp terminal	Applicable tool			
		Body	Head	Dice	
a	FVD5.5-10	YNT-1210S			JST
b	FVD22-10	YF-1 E-4	YNE-38	DH-123 DH-113	
(Note 1) c	R38-10	YPT-60-21		TD-124	
		YF-1 E-4	YET-60-1	TD-112	
(Note 1) d	R60-10	YPT-60-21		TD-125	
		YF-1 E-4	YET-60-1	TD-113	
e	FVD22-8	YF-1 E-4	YNE-38	DH-123 DH-113	
(Note 1) f	R38-8	YPT-60-21		TD-124	
		YF-1 E-4	YET-60-1	TD-112	
g	FVD2-4	YNT-1614			

Note 1. Coat the crimping part with an insulation tube.

2. Some crimp terminals may not be mounted depending on their sizes. Make sure to use the recommended ones or equivalent ones.

9. OPTIONS AND PERIPHERAL EQUIPMENT

9.5 Molded-case circuit breakers, fuses, magnetic contactors

(1) For main circuit power supply



- To prevent the converter unit and the drive unit from smoke and a fire, select a molded-case circuit breaker which shuts off with high speed.
- Always use one molded-case circuit breaker and one magnetic contactor with one converter unit.

When using a fuse instead of the molded-case circuit breaker, use the one having the specifications given in this section.

Converter unit	Drive unit	Molded-case circuit breaker (Note 1, 3)			Fuse			Magnetic contactor (Note 2)
		Frame, rated current		Voltage AC [V]	Class	Current [A]	Voltage AC [V]	
		Power factor improving DC reactor is not used	Power factor improving DC reactor is used					
MR-CR55K	MR-J4-DU30K_(-RJ)	225 A frame 175 A	225 A frame 150 A	240	T	300	300	S-N150
	MR-J4-DU37K_(-RJ)	225 A frame 225 A	225 A frame 175 A			400		S-N180
MR-CR55K4	MR-J4-DU30K_4(-RJ)	100 A frame 100 A	100 A frame 80 A	480	T	175	600	S-N65
	MR-J4-DU37K_4(-RJ)	125 A frame 125 A	100 A frame 100 A			200		S-N80
	MR-J4-DU45K_4(-RJ)	225 A frame 150 A	125 A frame 125 A			300		S-N95
	MR-J4-DU55K_4(-RJ)	225 A frame 175 A	225 A frame 150 A			300		S-N150

- Note
1. For compliance with the IEC/EN/UL/CSA standard, refer to appendix 2.
 2. Use a magnetic contactor with an operation delay time (interval between current being applied to the coil until closure of contacts) of 80 ms or less.
 3. Use a molded-case circuit breaker which has the same or more operation characteristics than our lineup.

9. OPTIONS AND PERIPHERAL EQUIPMENT

(2) For control circuit power supply

Install an overcurrent protection device (molded-case circuit breaker or fuse) to protect the branch circuit.

(a) Converter unit

Converter unit	Molded-case circuit breaker (Note)		Fuse (Class T)		Fuse (Class K5)	
	Frame, rated current	Voltage AC [V]	Current [A]	Voltage AC [V]	Current [A]	Voltage AC [V]
MR-CR55K	30 A frame 5 A	240	1	300	1	250
MR-CR55K4	30 A frame 5 A	480	1	600	1	600

Note. When having the converter unit comply with the IEC/EN/UL/CSA standard, refer to appendix 2.

(b) Drive unit

Drive unit	Molded-case circuit breaker (Note)		Fuse (Class T)		Fuse (Class K5)	
	Frame, rated current	Voltage AC [V]	Current [A]	Voltage AC [V]	Current [A]	Voltage AC [V]
MR-J4-DU30K_ (-RJ)	30 A frame 5 A	240	1	300	1	250
MR-J4-DU37K_ (-RJ)						
MR-J4-DU30K_4 (-RJ)	30 A frame 5 A	480	1	600	1	600
MR-J4-DU37K_4 (-RJ)						
MR-J4-DU45K_4 (-RJ)						
MR-J4-DU55K_4 (-RJ)						

Note. When having the drive unit comply with the IEC/EN/UL/CSA standard, refer to appendix 2.

9. OPTIONS AND PERIPHERAL EQUIPMENT

9.6 Power factor improving DC reactor

The following shows the advantages of using power factor improving DC reactor.

- It improves the power factor by increasing the form factor of the converter unit's input current.
- It decreases the power supply capacity.
- The input power factor is improved to about 95%.

When connecting the power factor improving DC reactor to the converter unit, be sure to remove the short bar across P1 and P2. If it remains connected, the effect of the power factor improving DC reactor is not produced.

When used, the power factor improving DC reactor generates heat. To release heat, therefore, leave a 10 cm or more clearance at each of the top and bottom, and a 5 cm or more clearance on each side.

Converter unit	Drive unit	Power factor improving DC reactor	Variable dimensions [mm]					Terminal screw	Mass [kg]	
			W	D	H	W1	X			
MR-CR55K	MR-J4-DU30K_(-RJ)	MR-DCL30K	135	255	215	80	232	M12	9.5	
	MR-J4-DU37K_(-RJ)	MR-DCL37K								
MR-CR55K4	MR-J4-DU30K_4(-RJ)	MR-DCL30K-4		205	200	80	75	175	M8	6.5
	MR-J4-DU37K_4(-RJ)	MR-DCL37K-4		225			197	7		
	MR-J4-DU45K_4(-RJ)	MR-DCL45K-4		240			212	7.5		
	MR-J4-DU55K_4(-RJ)	MR-DCL55K-4		260			232	9.5		

[Unit: mm]

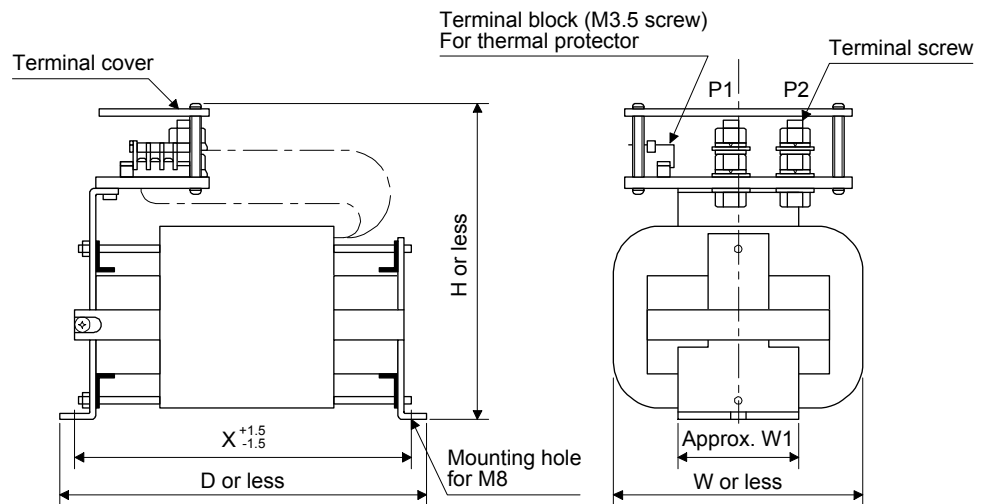

9. OPTIONS AND PERIPHERAL EQUIPMENT

9.7 Noise reduction techniques

Noises are classified into external noises which enter the converter unit and drive unit to cause them to malfunction and those radiated by the converter unit and drive unit to cause peripheral equipment to malfunction. Since the converter unit and drive unit are electronic devices which handle small signals, the following general noise reduction techniques are required.

Also, the drive unit can be a source of noise as its outputs are chopped by high carrier frequencies. If peripheral equipment malfunctions due to noise generation, take noise suppression measures. The measures will vary slightly with the routes of noise transmission.

(1) Noise reduction techniques

(a) General reduction techniques

- Avoid bundling power lines (input/output) and signal cables of the converter unit/drive unit together or running them in parallel to each other. Separate the power lines from the signal cables.
- Use a shielded twisted pair cable for connection with the encoder and for control signal transmission, and connect the external conductor of the cable to the SD terminal.
- Ground the converter unit, drive unit and the servo motor, etc. together at one point. (Refer to section 3.7.)

(b) Reduction techniques for external noises that cause the converter unit/drive unit to malfunction

If there are noise sources (such as a magnetic contactor, an electromagnetic brake, and many relays which make a large amount of noise) near the converter unit and drive unit and the converter unit/drive unit may malfunction, the following countermeasures are required.

- Provide surge killers on the noise sources to suppress noises.
- Attach data line filters to the signal cables.
- Ground the shields of the encoder connecting cable and the control signal cables with cable clamp fittings.
- Although a surge absorber is built into the converter unit, to protect the converter unit, drive unit and other equipment against large exogenous noise and lightning surge, attaching a varistor to the power input section of the equipment is recommended.

9. OPTIONS AND PERIPHERAL EQUIPMENT

- (c) Techniques for noises radiated by the converter unit/drive unit that cause peripheral equipment to malfunction

Noises produced by the converter unit and drive unit are classified into those radiated from the cables connected to the converter unit, drive unit and their main circuits (input and output circuits), those induced electromagnetically or statically by the signal cables of the peripheral equipment located near the main circuit cables, and those transmitted through the power supply cables.

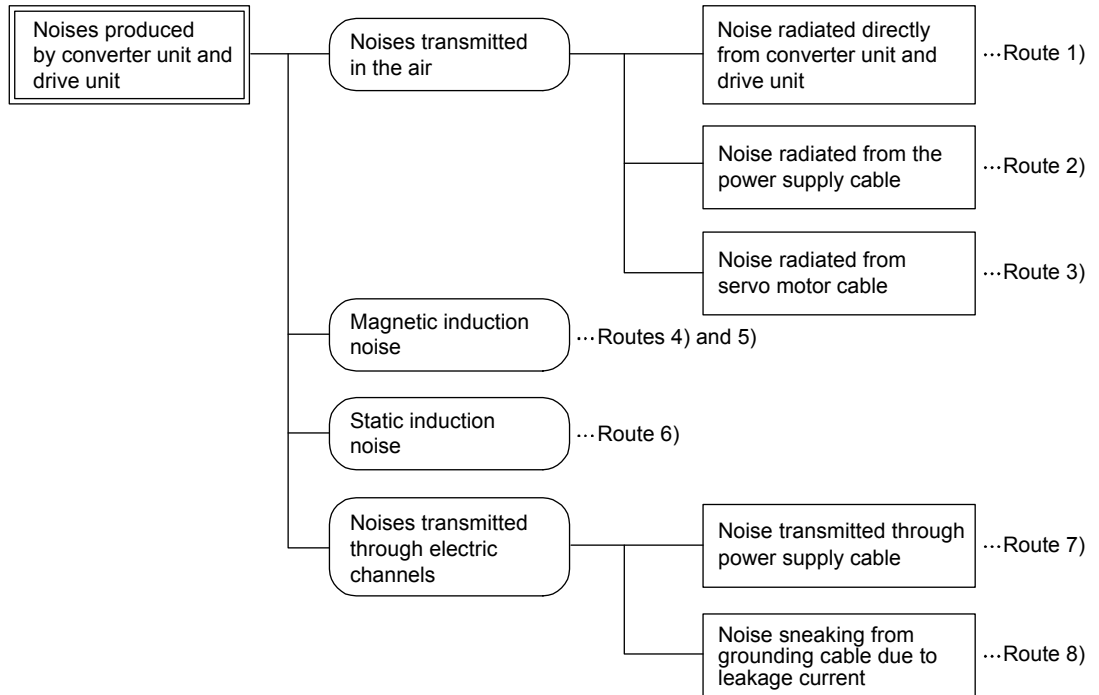

9. OPTIONS AND PERIPHERAL EQUIPMENT

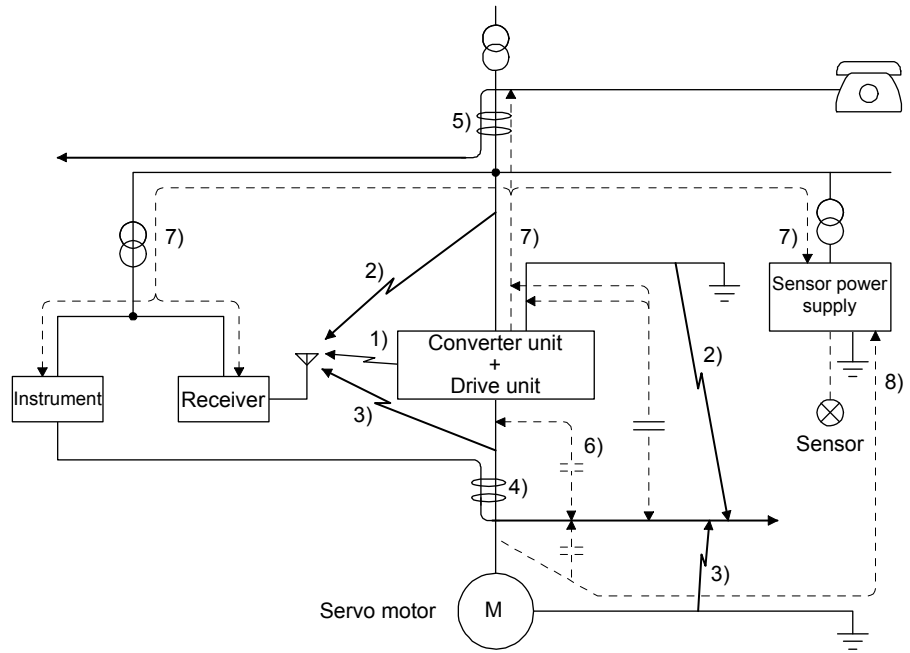

Noise transmission route	Suppression techniques
1) 2) 3)	<p>When measuring instruments, receivers, sensors, etc. which handle weak signals and may malfunction due to noise and/or their signal cables are contained in a cabinet together with the converter unit and drive unit or run near the converter unit and drive unit, such devices may malfunction due to noises transmitted through the air. The following techniques are required.</p> <ol style="list-style-type: none"> 1. Provide maximum clearance between easily affected devices and the converter unit/drive unit. 2. Provide maximum clearance between easily affected signal cables and the I/O cables of the converter unit/drive unit. 3. Avoid wiring the power lines (input/output lines of the converter unit/drive unit) and signal lines side by side or bundling them together. 4. Insert a line noise filter to the I/O cables or a radio noise filter on the input line. 5. Use shielded wires for signal and power lines or put lines in separate metal conduits.
4) 5) 6)	<p>When the power lines and the signal lines are laid side by side or bundled together, magnetic induction noise and static induction noise will be transmitted through the signal cables and malfunction may occur. The following techniques are required.</p> <ol style="list-style-type: none"> 1. Provide maximum clearance between easily affected devices and the converter unit/drive unit. 2. Provide maximum clearance between easily affected signal cables and the I/O cables of the converter unit/drive unit. 3. Avoid wiring the power lines (input/output lines of the converter unit/drive unit) and signal lines side by side or bundling them together. 4. Use shielded wires for signal and power lines or put lines in separate metal conduits.
7)	<p>When the power supply of peripheral equipment is connected to the power supply of the converter unit/drive unit systems, noises produced by the converter unit and drive unit may be transmitted back through the power supply cable and the devices may malfunction. The following techniques are required.</p> <ol style="list-style-type: none"> 1. Install the radio noise filter (FR-BIF-(H)) on the power lines (Input lines) of the converter unit/drive unit. 2. Install the line noise filter (FR-BSF01/FR-BLF) on the power lines of the converter unit/drive unit.
8)	<p>When the grounding wires of peripheral equipment are connected to the converter unit/drive unit to make a closed loop circuit, leakage current may flow to malfunction the peripheral equipment. If so, malfunction may be prevented by disconnecting the grounding cable of the peripheral device.</p>

9. OPTIONS AND PERIPHERAL EQUIPMENT

(2) Noise reduction techniques

This section explains how to use the line noise filter unique to the converter unit and drive unit. Other noise reduction products are the same as those for MR-J4-_-(-RJ). When you use MR-J4-DU_A_(-RJ), refer to section 11.14 (2) of "MR-J4-_A_(-RJ) Servo Amplifier Instruction Manual". When you use MR-J4-DU_B_(-RJ), refer to section 11.14 (2) of "MR-J4-_B_(-RJ) Servo Amplifier Instruction Manual".

(a) Line noise filter (FR-BLF)

This filter is effective in suppressing noises radiated from the power supply side and output side of the converter unit, drive unit and also in suppressing high-frequency leakage current (0-phase current). It especially affects the noises between 0.5 MHz and 5 MHz band. The filters are used with the main circuit power supply of the converter unit (L1, L2, and L3) and the power output of the drive unit (U, V, and W).

1) Usage

Pass the 3-phase wires through four line noise filters. When you use the line noise filters with the power wires, passing the power wires together with the ground wire will reduce the filter effect.

Run the ground wire separately from the power wires.

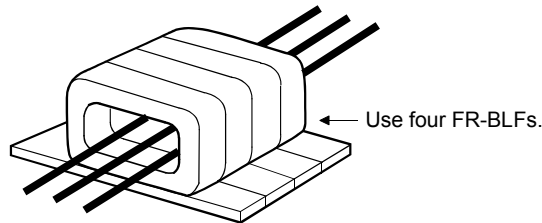

2) Dimensions

[Unit: mm]

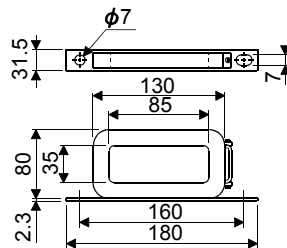

9. OPTIONS AND PERIPHERAL EQUIPMENT

9.8 Earth-leakage current breaker

(1) Selection method

High-frequency chopper currents controlled by pulse width modulation flow in the AC servo circuits. Leakage currents containing harmonic contents are larger than those of the motor which is run with a commercial power supply.

Select an earth-leakage current breaker according to the following formula, and ground the drive unit, servo motor, etc. securely.

To minimize leakage currents, make the input and output cables as short as possible, and make the grounding cable longer than 30 cm.

$$\text{Rated sensitivity current} \geq 10 \cdot \{I_{gl} + I_{gn} + I_{ga} + K \cdot (I_{g2} + I_{gm})\} \text{ [mA]} \dots\dots\dots (9.1)$$

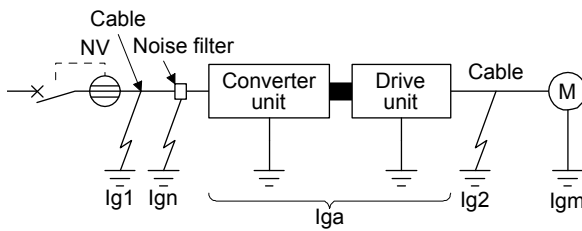

Earth-leakage current breaker		K
Type	Mitsubishi products	
Models provided with harmonic and surge reduction techniques	NV-SP NV-SW NV-CP NV-CW NV-HW	1
General models	BV-C1 NFB NV-L	3

I_{gl}: Leakage current on the electric channel from the earth-leakage current breaker to the input terminals of the drive unit (found from Fig. 9.1.)

I_{g2}: Leakage current on the electric channel from the output terminals of the drive unit to the servo motor (found from Fig. 9.1.)

I_{gn}: Leakage current when a filter is connected to the input side (4.4 mA per one FR-BIF-(H))

I_{ga}: Leakage current of the converter unit/drive unit (found from table 9.4.)

I_{gm}: Leakage current of the servo motor (found from table 9.3.)

Table 9.3 Servo motor leakage current example (I_{gm})

Servo motor output [kW]	Leakage current [mA]
30 to 55	2.5

Table 9.4 Converter unit/drive unit's leakage current example (I_{ga})

Converter unit Drive unit	Leakage current [mA]
All series	5

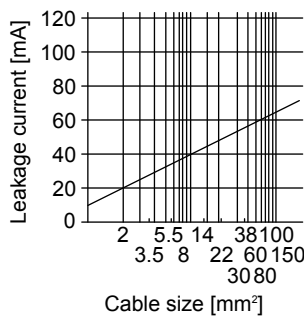

200 V class

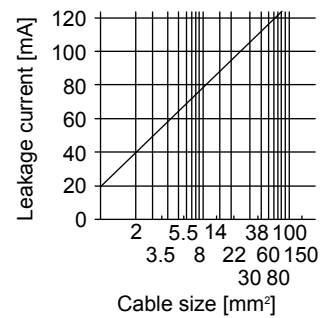

400 V class

Fig. 9.1 Example of leakage current per km (I_{gl}, I_{g2}) for CV cable run in metal conduit

9. OPTIONS AND PERIPHERAL EQUIPMENT

(2) Selection example

Indicated below is an example of selecting an earth-leakage current breaker under the following conditions.

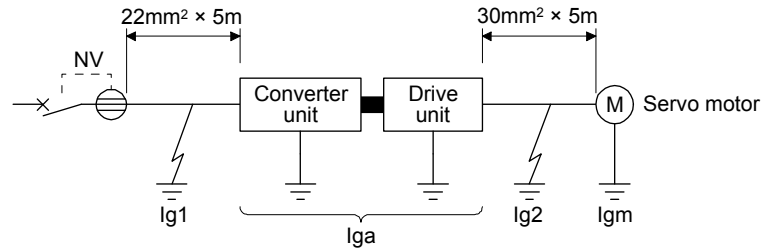

Use an earth-leakage current breaker designed for suppressing harmonics/surges.
Find the terms of equation (9.1) from the diagram.

$$I_{g1} = 95 \times \frac{5}{1000} = 0.475 \text{ [mA]}$$

$$I_{g2} = 105 \times \frac{5}{1000} = 0.525 \text{ [mA]}$$

$$I_{gn} = 0 \text{ (not used)}$$

$$I_{ga} = 5 \text{ [mA]}$$

$$I_{gm} = 2.5 \text{ [mA]}$$

Insert these values in equation (9.1).

$$I_g \geq 10 \cdot \{0.475 + 0 + 5 + 1 \cdot (0.525 + 2.5)\} \\ \geq 85 \text{ [mA]}$$

According to the result of calculation, use an earth-leakage current breaker having the rated sensitivity current (I_g) of 85 mA or more. Use an earth-leakage current breaker having I_g of 200 mA with the NV-SP/SW/CP/CW/HW series.

9. OPTIONS AND PERIPHERAL EQUIPMENT

9.9 EMC filter (recommended)

It is recommended that one of the following filters be used to comply with EN EMC directive. Some EMC filters have large in leakage current. When using an EMC filter, always use one for each converter unit.

9.9.1 Combinations of converter unit/drive unit

Converter unit	Drive unit	Recommended filter (Soshin Electric)				Mass [kg]
		Model	Rated current [A]	Rated voltage [VAC]	Leakage current [mA]	
MR-CR55K	MR-J4-DU30K_(-RJ) MR-J4-DU37K_(-RJ)	(Note) HF3200A-UN	200	250	9	18
MR-CR55K4	MR-J4-DU30K_4(-RJ) MR-J4-DU37K_4(-RJ) MR-J4-DU45K_4(-RJ) MR-J4-DU55K_4(-RJ)	TF3150C-TX	150	500	5.5	31

Note. A surge protector is separately required to use any of these EMC filters.

9.9.2 Connection example

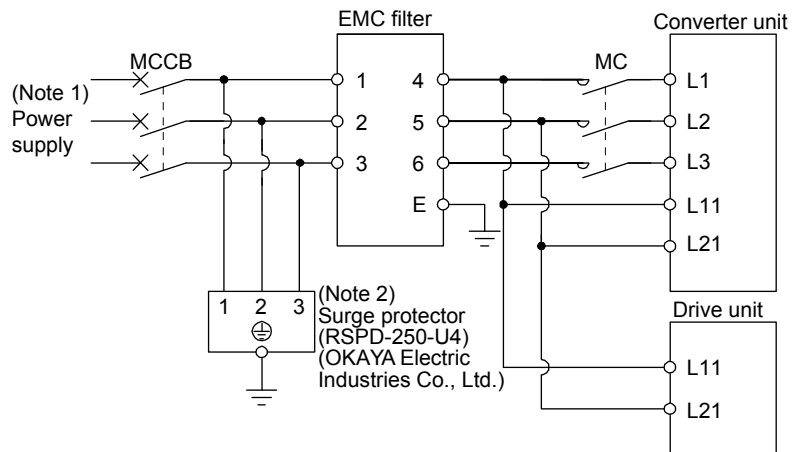

- Note 1. For the power supply specifications, refer to section 1.2.
 Note 2. The example is when a surge protector is connected.

9. OPTIONS AND PERIPHERAL EQUIPMENT

9.9.3 Dimensions

(1) HF3200A-UN

[Unit: mm]

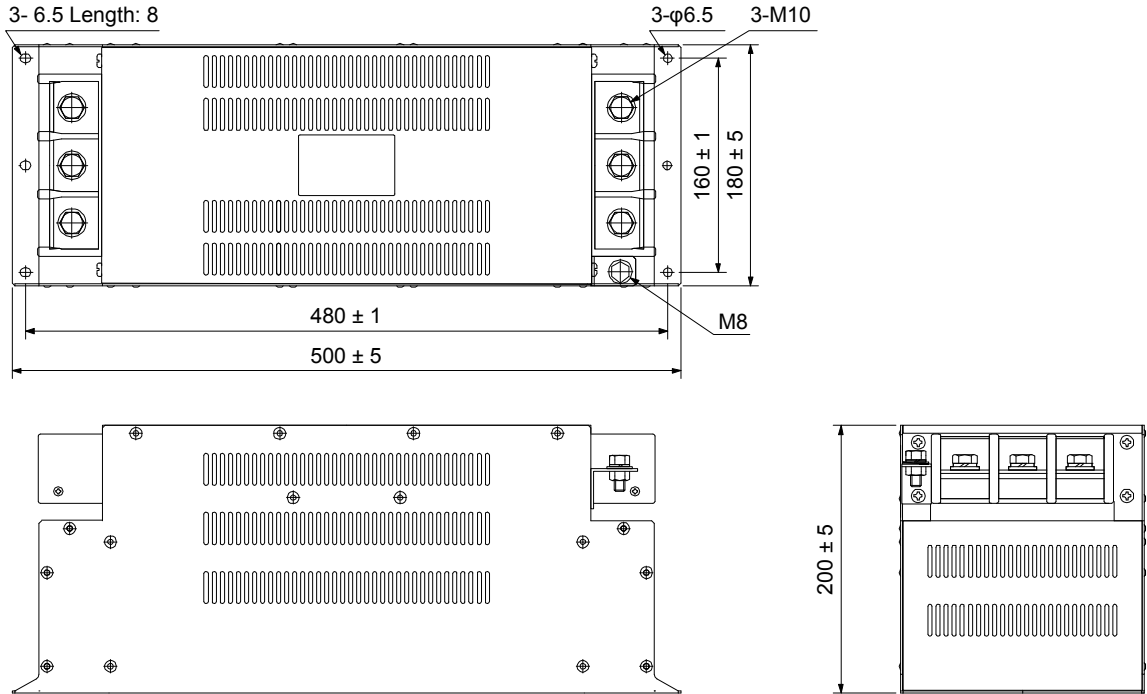

(2) TF3150C-TX

[Unit: mm]

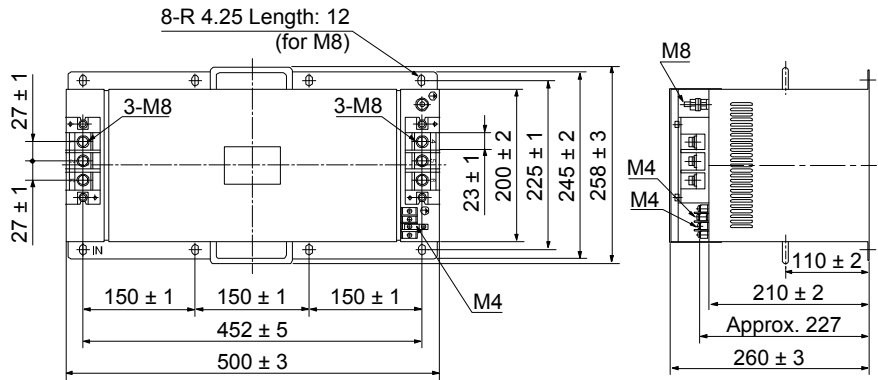

9. OPTIONS AND PERIPHERAL EQUIPMENT

9.10 FR-BU2-(H) brake unit

POINT							
	<ul style="list-style-type: none"> ● EM2 of the drive unit is the signal having the same contents as EM1 of the drive unit in torque control mode. ● Use a 200 V class brake unit and a resistor unit with a 200 V class converter unit, and a 400 V class brake unit and a resistor unit with a 400 V class converter unit. Combination of different voltage class units cannot be used. ● When a brake unit and a resistor unit are installed horizontally or diagonally, the heat dissipation effect diminishes. Install them on a flat surface vertically. ● The temperature of the resistor unit case will be higher than the ambient temperature by 100 °C or over. Keep cables and flammable materials away from the case. ● Ambient temperature condition of the brake unit is between -10 °C and 50 °C. Note that the condition is different from the ambient temperature condition of the converter unit (between 0 °C and 55 °C). ● Configure the circuit to shut down the power-supply with the alarm output of the brake unit and the resistor unit under abnormal condition. ● Use the brake unit with a combination indicated in section 9.10.1. ● Brake unit and regenerative options (Regenerative resistor) cannot be used simultaneously. ● When using the brake unit, set the parameters as follows. 						
	<table border="1" style="width: 100%; border-collapse: collapse;"> <thead> <tr> <th style="width: 70%;">Parameter</th> <th style="width: 30%;">Setting value</th> </tr> </thead> <tbody> <tr> <td>[Pr. PA01] of the converter unit</td> <td style="text-align: center;">__ 0 0 (Initial value)</td> </tr> <tr> <td>[Pr. PA02] of the drive unit</td> <td style="text-align: center;">__ 0 1</td> </tr> </tbody> </table>	Parameter	Setting value	[Pr. PA01] of the converter unit	__ 0 0 (Initial value)	[Pr. PA02] of the drive unit	__ 0 1
Parameter	Setting value						
[Pr. PA01] of the converter unit	__ 0 0 (Initial value)						
[Pr. PA02] of the drive unit	__ 0 1						

Connect the brake unit to the bus of the converter unit (L+ and L- of TE2-1) for use. As compared to the MR-RB regenerative option, the brake unit can return larger power. Use the brake unit when the regenerative option cannot provide sufficient regenerative capability.

When using the brake unit, always refer to "FR-BU2 Brake Unit Instruction Manual".

9.10.1 Selection

Use a combination of converter unit, brake unit and resistor unit listed below.

Brake unit		Resistor unit	Number of connected units	Permissible continuous power [kW]	Resultant resistance [Ω]	Converter unit
200 V class	FR-BU2-55K	FR-BR-55K	2 (parallel)	7.82	1	MR-CR55K
		MT-BR5-55K	2 (parallel)	11.0	1	
400 V class	FR-BU2-H55K	FR-BR-H55K	2 (parallel)	7.82	4	MR-CR55K4
	FR-BU2-H75K	MT-BR5-H75K	2 (parallel)	15.0	3.25	

9. OPTIONS AND PERIPHERAL EQUIPMENT

9.10.2 Brake unit parameter setting

Normally, changing the FR-BU2-(H) parameter is not required. Whether a parameter can be changed or not is listed below.

Parameter		Change possible/ impossible	Remark
No.	Name		
0	Brake mode switchover	Impossible	Do not change the parameter.
1	Monitor display data selection	Possible	Refer to "FR-BU2 Brake Unit Instruction Manual".
2	Input terminal function selection 1	Impossible	Do not change the parameter.
3	Input terminal function selection 2		
77	Parameter write selection		
78	Cumulative energization time carrying-over times		
CLr	Parameter clear		
ECL	Alarm history clear		
C1	For manufacturer setting		

9.10.3 Connection example

POINT
<ul style="list-style-type: none"> ● Connecting PR terminal of the brake unit to L+ terminal of the converter unit results in a brake unit malfunction. Always connect the PR terminal of the brake unit to the PR terminal of the resistor unit.

(1) Combination with FR-BR-(H) resistor unit

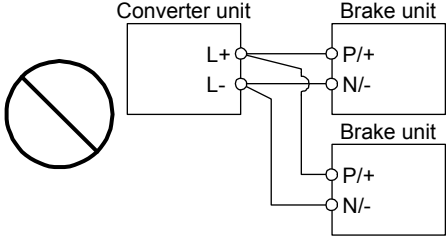
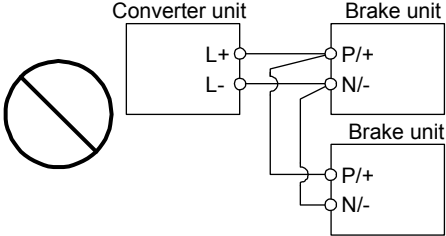
POINT
<ul style="list-style-type: none"> ● To use brake units with a parallel connection, use two sets of FR-BU2-(H) brake unit. Combination with other brake unit results in alarm occurrence or malfunction. ● Always connect the terminals for master/slave (MSG to MSG, SD to SD) between the two brake units. ● Do not connect as follows.

Connecting two cables to L+ and L- terminals

Passing wiring

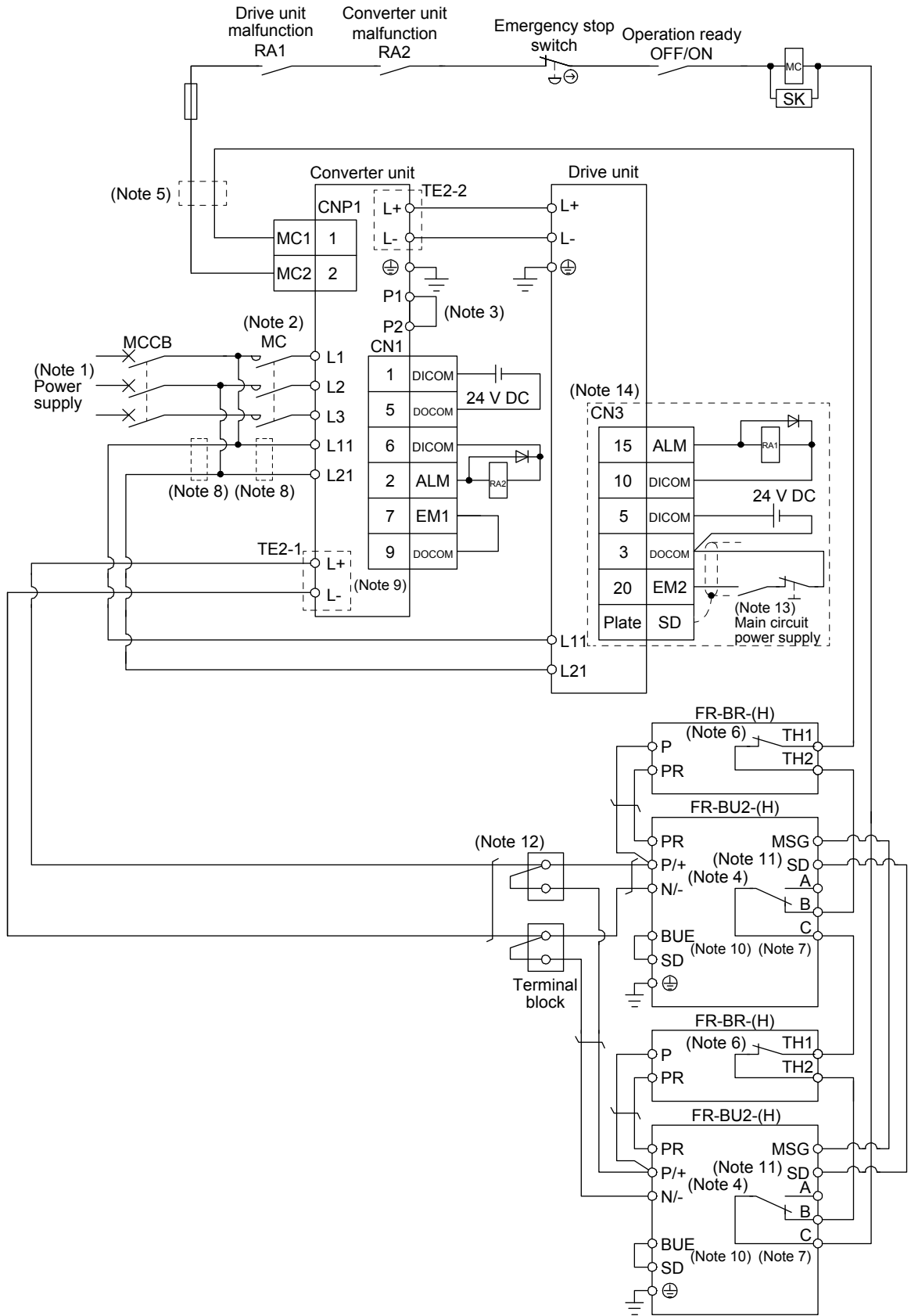
9. OPTIONS AND PERIPHERAL EQUIPMENT

(a) When magnetic contactor drive output is enabled



9. OPTIONS AND PERIPHERAL EQUIPMENT

- Note
1. For the power supply specifications, refer to section 1.2.
 2. Use a magnetic contactor with an operation delay time (interval between current being applied to the coil until closure of contacts) of 80 ms or less. Depending on the main circuit voltage and operation pattern, bus voltage decreases, and that may cause the forced stop deceleration to shift to the dynamic brake deceleration. When dynamic brake deceleration is not required, slow the time to turn off the magnetic contactor.
 3. P1 and P2 are connected by default. When using the power factor improving DC reactor, connect P1 and P2 after removing the short bar across them. Refer to section 9.6 for details.
 4. Connect P/+ and N/- terminals of the brake unit to a correct destination. Incorrect connection destination results in the converter unit and brake unit malfunction.
 5. For 400 V class, a step-down transformer is required.
 6. Contact rating: 1b contact, 110 V AC, 5 A/220 V AC, 3 A
Normal condition: TH1-TH2 is conducting. Abnormal condition: TH1-TH2 is not conducting.
 7. Contact rating: 230 V AC, 0.3 A/30 V DC, 0.3 A
Normal condition: B-C is conducting./A-C is not conducting. Abnormal condition: B-C is not conducting./A-C is conducting.
 8. Install an overcurrent protection device (molded-case circuit breaker or fuse) to protect the branch circuit. (Refer to section 9.5.)
 9. Do not connect more than one cable to each L+ and L- terminals of TE2-1 of the converter unit.
 10. Always connect BUE and SD terminals. (factory-wired)
 11. Connect MSG and SD terminals of the brake unit to a correct destination. Incorrect connection destination results in the converter unit and brake unit malfunction.
 12. For connecting L+ and L- terminals of TE2-1 of the converter unit to the terminal block, use the cable indicated in (4) of this section.
 13. Configure a circuit to turn off EM2 in the drive unit when the main circuit power is turned off to prevent an unexpected restart of the drive unit.
 14. The wiring is for MR-J4-DU_B_(-RJ). The connection for the interface of MR-J4-DU_(-RJ) is the same as in the case of MR-J4_(-RJ). Refer to each servo amplifier instruction manual.

9. OPTIONS AND PERIPHERAL EQUIPMENT

(b) When magnetic contactor drive output is disabled

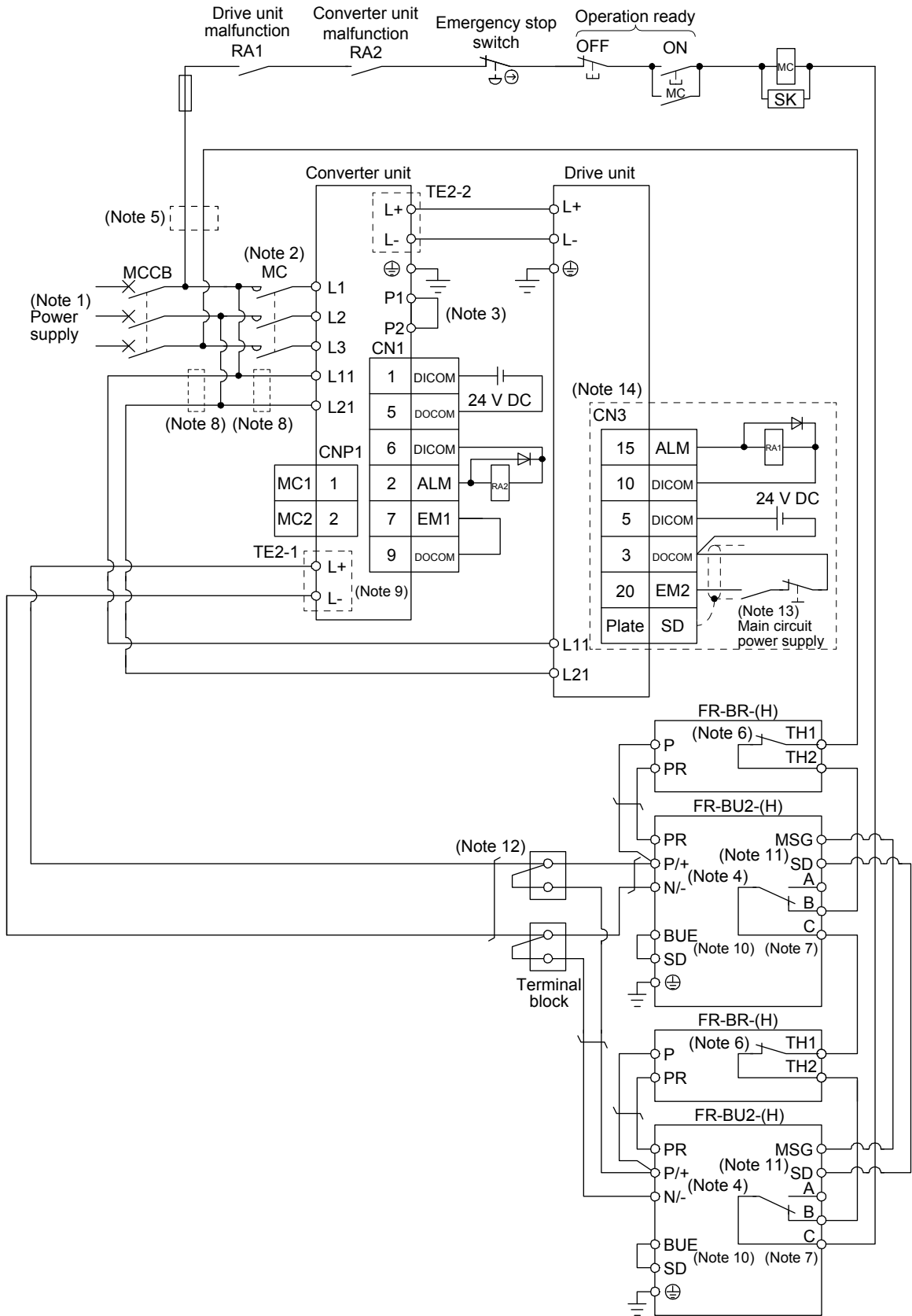

9. OPTIONS AND PERIPHERAL EQUIPMENT

- Note
1. For the power supply specifications, refer to section 1.2.
 2. Use a magnetic contactor with an operation delay time (interval between current being applied to the coil until closure of contacts) of 80 ms or less. Depending on the main circuit voltage and operation pattern, bus voltage decreases, and that may cause the forced stop deceleration to shift to the dynamic brake deceleration. When dynamic brake deceleration is not required, slow the time to turn off the magnetic contactor.
 3. P1 and P2 are connected by default. When using the power factor improving DC reactor, connect P1 and P2 after removing the short bar across them. Refer to section 9.6 for details.
 4. Connect P/+ and N/- terminals of the brake unit to a correct destination. Incorrect connection destination results in the converter unit and brake unit malfunction.
 5. For 400 V class, a step-down transformer is required.
 6. Contact rating: 1b contact, 110 V AC, 5 A/220 V AC, 3 A
Normal condition: TH1-TH2 is conducting. Abnormal condition: TH1-TH2 is not conducting.
 7. Contact rating: 230 V AC, 0.3 A/30 V DC, 0.3 A
Normal condition: B-C is conducting./A-C is not conducting. Abnormal condition: B-C is not conducting./A-C is conducting.
 8. Install an overcurrent protection device (molded-case circuit breaker or fuse) to protect the branch circuit. (Refer to section 9.5.)
 9. Do not connect more than one cable to each L+ and L- terminals of TE2-1 of the converter unit.
 10. Always connect BUE and SD terminals. (factory-wired)
 11. Connect MSG and SD terminals of the brake unit to a correct destination. Incorrect connection destination results in the converter unit and brake unit malfunction.
 12. For connecting L+ and L- terminals of TE2-1 of the converter unit to the terminal block, use the cable indicated in (4) of this section.
 13. Configure a circuit to turn off EM2 in the drive unit when the main circuit power is turned off to prevent an unexpected restart of the drive unit.
 14. The wiring is for MR-J4-DU_B_(-RJ). The connection for the interface of MR-J4-DU_(-RJ) is the same as in the case of MR-J4_(-RJ). Refer to each servo amplifier instruction manual.

9. OPTIONS AND PERIPHERAL EQUIPMENT

- (2) Combination with MT-BR5-(H) resistor unit
 - (a) When connecting a brake unit to a converter unit
 - 1) When magnetic contactor drive output is enabled

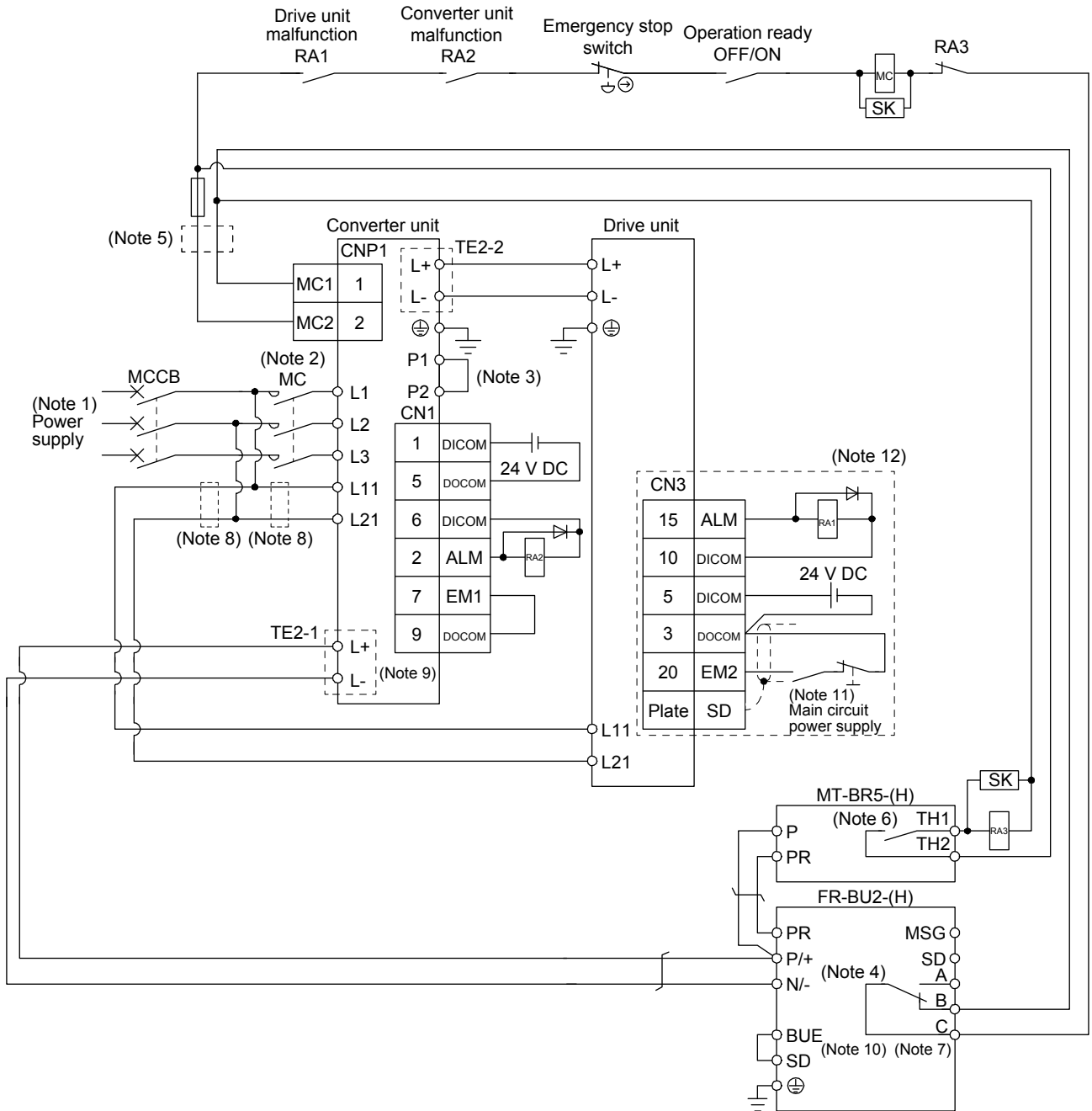

9. OPTIONS AND PERIPHERAL EQUIPMENT

- Note
1. For the power supply specifications, refer to section 1.2.
 2. Use a magnetic contactor with an operation delay time (interval between current being applied to the coil until closure of contacts) of 80 ms or less. Depending on the main circuit voltage and operation pattern, bus voltage decreases, and that may cause the forced stop deceleration to shift to the dynamic brake deceleration. When dynamic brake deceleration is not required, slow the time to turn off the magnetic contactor.
 3. P1 and P2 are connected by default. When using the power factor improving DC reactor, connect P1 and P2 after removing the short bar across them. Refer to section 9.6 for details.
 4. Connect P/+ and N/- terminals of the brake unit to a correct destination. Incorrect connection destination results in the converter unit and brake unit malfunction.
 5. For 400 V class, a step-down transformer is required.
 6. Contact rating: 1a contact, 110 V AC, 5 A/220 V AC, 3 A
Normal condition: TH1-TH2 is not conducting. Abnormal condition: TH1-TH2 is conducting.
 7. Contact rating: 230 V AC, 0.3 A/30 V DC, 0.3 A
Normal condition: B-C is conducting./A-C is not conducting. Abnormal condition: B-C is not conducting./A-C is conducting.
 8. Install an overcurrent protection device (molded-case circuit breaker or fuse) to protect the branch circuit. (Refer to section 9.5.)
 9. Do not connect more than one cable to each L+ and L- terminals of TE2-1 of the converter unit.
 10. Always connect BUE and SD terminals. (factory-wired)
 11. Configure a circuit to turn off EM2 in the drive unit when the main circuit power is turned off to prevent an unexpected restart of the drive unit.
 12. The wiring is for MR-J4-DU_B_(-RJ). The connection for the interface of MR-J4-DU_(-RJ) is the same as in the case of MR-J4_(-RJ). Refer to each servo amplifier instruction manual.

9. OPTIONS AND PERIPHERAL EQUIPMENT

2) When magnetic contactor drive output is disabled

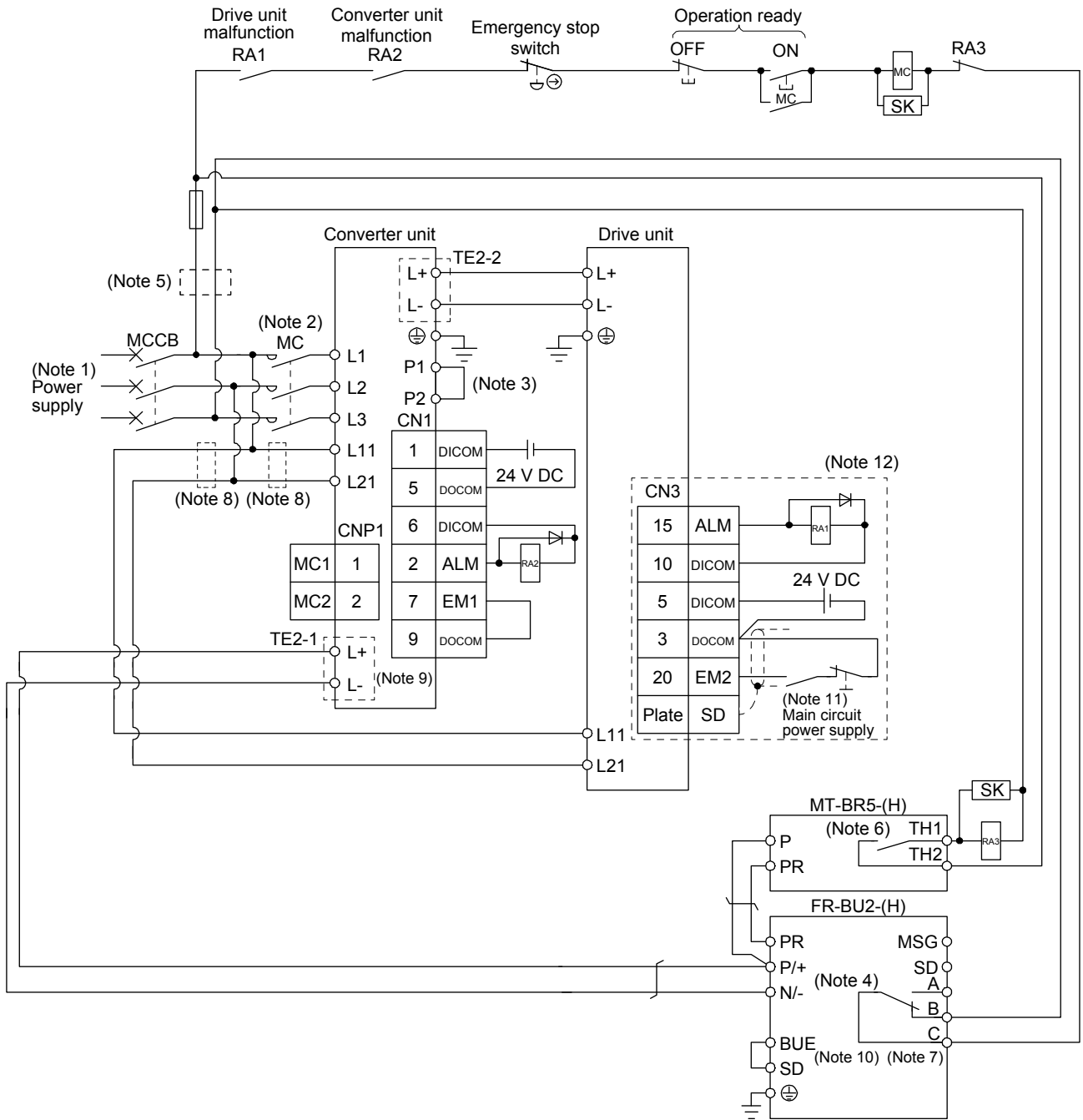

9. OPTIONS AND PERIPHERAL EQUIPMENT

- Note
1. For the power supply specifications, refer to section 1.2.
 2. Use a magnetic contactor with an operation delay time (interval between current being applied to the coil until closure of contacts) of 80 ms or less. Depending on the main circuit voltage and operation pattern, bus voltage decreases, and that may cause the forced stop deceleration to shift to the dynamic brake deceleration. When dynamic brake deceleration is not required, slow the time to turn off the magnetic contactor.
 3. P1 and P2 are connected by default. When using the power factor improving DC reactor, connect P1 and P2 after removing the short bar across them. Refer to section 9.6 for details.
 4. Connect P/+ and N/- terminals of the brake unit to a correct destination. Incorrect connection destination results in the converter unit and brake unit malfunction.
 5. For 400 V class, a step-down transformer is required.
 6. Contact rating: 1a contact, 110 V AC, 5 A/220 V AC, 3 A
Normal condition: TH1-TH2 is not conducting. Abnormal condition: TH1-TH2 is conducting.
 7. Contact rating: 230 V AC, 0.3 A/30 V DC, 0.3 A
Normal condition: B-C is conducting./A-C is not conducting. Abnormal condition: B-C is not conducting./A-C is conducting.
 8. Install an overcurrent protection device (molded-case circuit breaker or fuse) to protect the branch circuit. (Refer to section 9.5.)
 9. Do not connect more than one cable to each L+ and L- terminals of TE2-1 of the converter unit.
 10. Always connect BUE and SD terminals. (factory-wired)
 11. Configure a circuit to turn off EM2 in the drive unit when the main circuit power is turned off to prevent an unexpected restart of the drive unit.
 12. The wiring is for MR-J4-DU_B_(-RJ). The connection for the interface of MR-J4-DU_(-RJ) is the same as in the case of MR-J4_(-RJ). Refer to each servo amplifier instruction manual.

9. OPTIONS AND PERIPHERAL EQUIPMENT

(b) When connecting two brake units to a converter unit

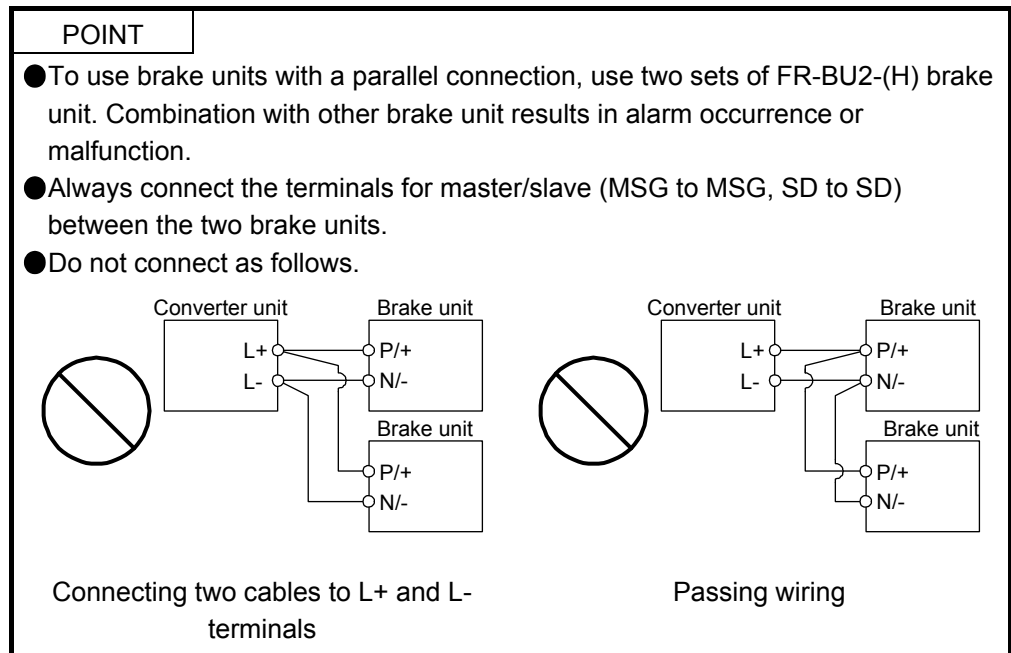

9. OPTIONS AND PERIPHERAL EQUIPMENT

1) When magnetic contactor drive output is enabled

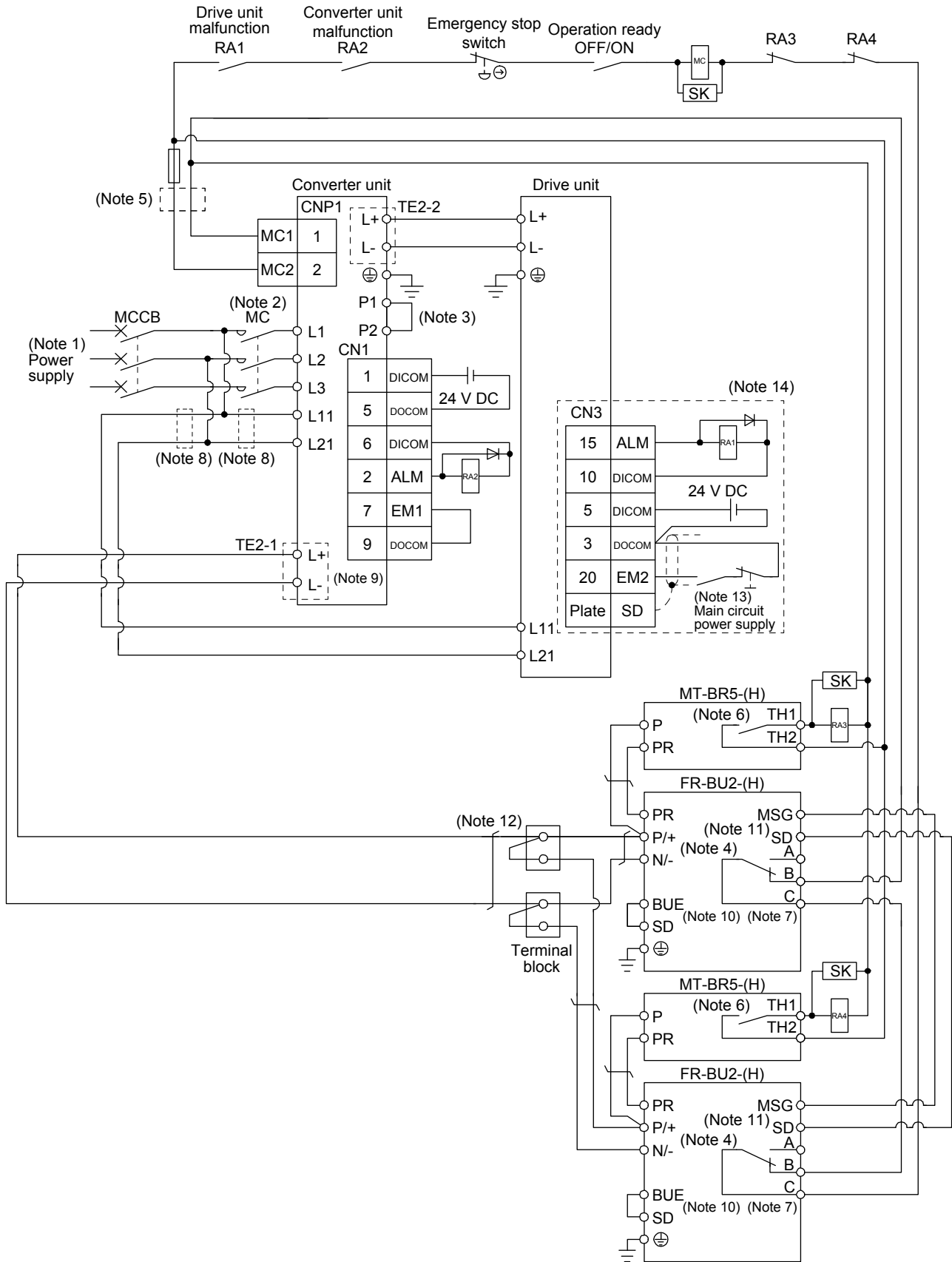

9. OPTIONS AND PERIPHERAL EQUIPMENT

- Note
1. For the power supply specifications, refer to section 1.2.
 2. Use a magnetic contactor with an operation delay time (interval between current being applied to the coil until closure of contacts) of 80 ms or less. Depending on the main circuit voltage and operation pattern, bus voltage decreases, and that may cause the forced stop deceleration to shift to the dynamic brake deceleration. When dynamic brake deceleration is not required, slow the time to turn off the magnetic contactor.
 3. P1 and P2 are connected by default. When using the power factor improving DC reactor, connect P1 and P2 after removing the short bar across them. Refer to section 9.6 for details.
 4. Connect P/+ and N/- terminals of the brake unit to a correct destination. Incorrect connection destination results in the converter unit and brake unit malfunction.
 5. For 400 V class, a step-down transformer is required.
 6. Contact rating: 1a contact, 110 V AC, 5 A/220 V AC, 3 A
Normal condition: TH1-TH2 is not conducting. Abnormal condition: TH1-TH2 is conducting.
 7. Contact rating: 230 V AC, 0.3 A/30 V DC, 0.3 A
Normal condition: B-C is conducting./A-C is not conducting. Abnormal condition: B-C is not conducting./A-C is conducting.
 8. Install an overcurrent protection device (molded-case circuit breaker or fuse) to protect the branch circuit. (Refer to section 9.5.)
 9. Do not connect more than one cable to each L+ and L- terminals of TE2-1 of the converter unit.
 10. Always connect BUE and SD terminals. (factory-wired)
 11. Connect MSG and SD terminals of the brake unit to a correct destination. Incorrect connection destination results in the converter unit and brake unit malfunction.
 12. For connecting L+ and L- terminals of the converter unit to the terminal block, use the cable indicated in (4) of this section.
 13. Configure a circuit to turn off EM2 in the drive unit when the main circuit power is turned off to prevent an unexpected restart of the drive unit.
 14. The wiring is for MR-J4-DU_B_(-RJ). The connection for the interface of MR-J4-DU_(-RJ) is the same as in the case of MR-J4_(-RJ). Refer to each servo amplifier instruction manual.

9. OPTIONS AND PERIPHERAL EQUIPMENT

2) When magnetic contactor drive output is disabled

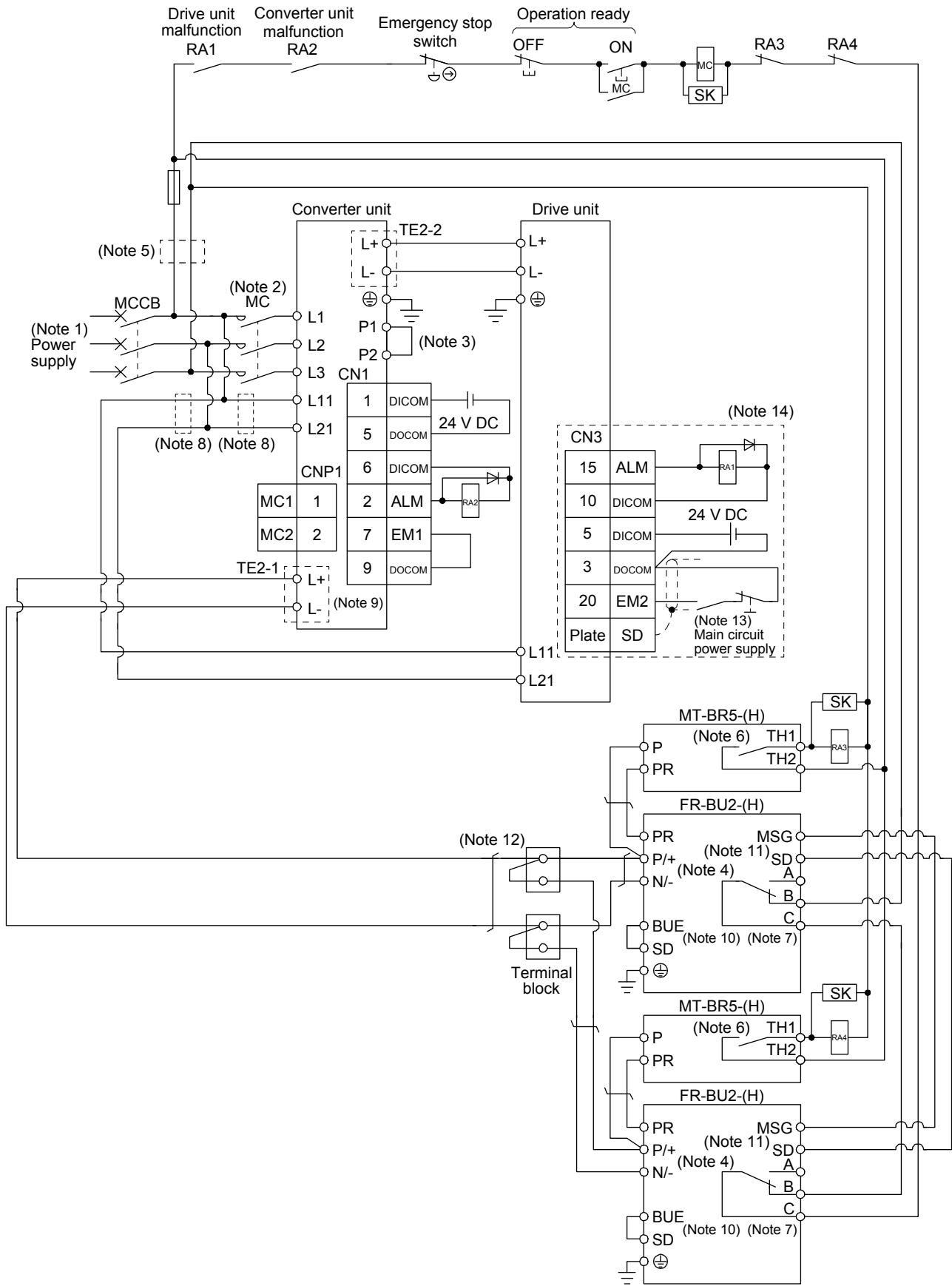

9. OPTIONS AND PERIPHERAL EQUIPMENT

- Note
1. For the power supply specifications, refer to section 1.2.
 2. Use a magnetic contactor with an operation delay time (interval between current being applied to the coil until closure of contacts) of 80 ms or less. Depending on the main circuit voltage and operation pattern, bus voltage decreases, and that may cause the forced stop deceleration to shift to the dynamic brake deceleration. When dynamic brake deceleration is not required, slow the time to turn off the magnetic contactor.
 3. P1 and P2 are connected by default. When using the power factor improving DC reactor, connect P1 and P2 after removing the short bar across them. Refer to section 9.6 for details.
 4. Connect P/+ and N/- terminals of the brake unit to a correct destination. Incorrect connection destination results in the converter unit and brake unit malfunction.
 5. For 400 V class, a step-down transformer is required.
 6. Contact rating: 1a contact, 110 V AC, 5 A/220 V AC, 3 A
Normal condition: TH1-TH2 is not conducting. Abnormal condition: TH1-TH2 is conducting.
 7. Contact rating: 230 V AC, 0.3 A/30 V DC, 0.3 A
Normal condition: B-C is conducting./A-C is not conducting. Abnormal condition: B-C is not conducting./A-C is conducting.
 8. Install an overcurrent protection device (molded-case circuit breaker or fuse) to protect the branch circuit. (Refer to section 9.5.)
 9. Do not connect more than one cable to each L+ and L- terminals of TE2-1 of the converter unit.
 10. Always connect BUE and SD terminals. (factory-wired)
 11. Connect MSG and SD terminals of the brake unit to a correct destination. Incorrect connection destination results in the converter unit and brake unit malfunction.
 12. For connecting L+ and L- terminals of the converter unit to the terminal block, use the cable indicated in (4) of this section.
 13. Configure a circuit to turn off EM2 in the drive unit when the main circuit power is turned off to prevent an unexpected restart of the drive unit.
 14. The wiring is for MR-J4-DU_B_(-RJ). The connection for the interface of MR-J4-DU_(-RJ) is the same as in the case of MR-J4_(-RJ). Refer to each servo amplifier instruction manual.

9. OPTIONS AND PERIPHERAL EQUIPMENT

(3) Connection instructions

The cables between the converter unit and the brake unit, and between the resistor unit and the brake unit should be as short as possible. Always twist the cable longer than 5 m (twist five times or more per one meter). Even when the cable is twisted, the cable should be less than 10 m. Using cables longer than 5 m without twisting or twisted cables longer than 10 m may result in the brake unit malfunction.

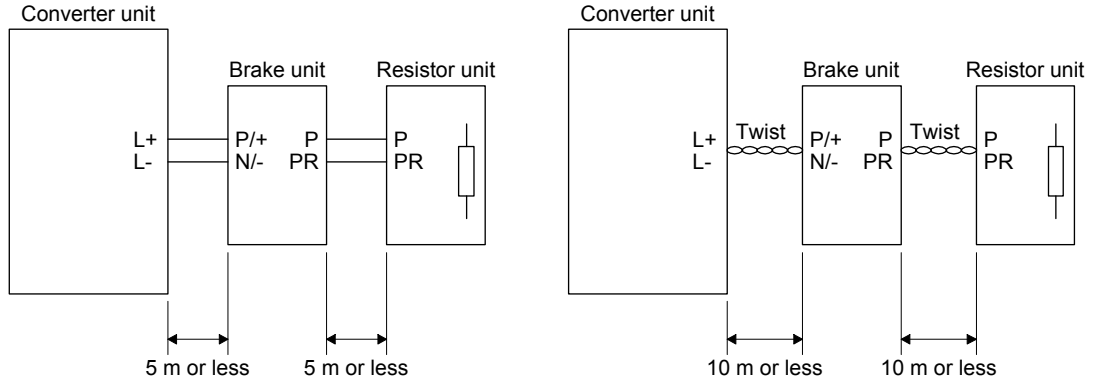

(4) Wires

(a) Wires for the brake unit

For the brake unit, HIV wire (600 V Grade heat-resistant polyvinyl chloride insulated wire) is recommended.

1) Main circuit terminal

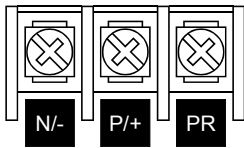

Terminal block

Brake unit		Main circuit terminal screw size	Crimp terminal N/-, P/+, PR, ⊕	Tightening torque [N•m]	Wire size	
					N/-, P/+, PR, ⊕	
					HIV wire [mm ²]	AWG
200 V class	FR-BU2-55K	M6	14-6	4.4	14	6
400 V class	FR-BU2-H55K	M5	5.5-5	2.5	5.5	10
	FR-BU2-H75K	M6	14-6	4.4	14	6

2) Control circuit terminal

POINT

● Under tightening can cause a cable disconnection or malfunction. Over tightening can cause a short circuit or malfunction due to damage to the screw or the brake unit.

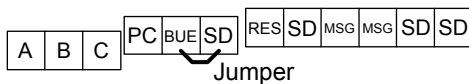

Terminal block

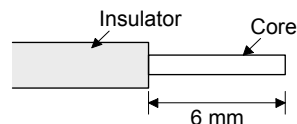

Wire the stripped cable after twisting to prevent the cable from becoming loose. In addition, do not solder it.

Screw size: M3

Tightening torque: 0.5 N•m to 0.6 N•m

Wire size: 0.3 mm² to 0.75 mm²

Screw driver: Small flat-blade screwdriver

(Tip thickness: 0.4 mm/Tip width 2.5 mm)

9. OPTIONS AND PERIPHERAL EQUIPMENT

- (b) Cables for connecting the converter unit and a distribution terminal block when connecting two sets of the brake unit

Brake unit		Wire size	
		HIV wire [mm ²]	AWG
200 V class	FR-BU2-55K	38	2
400 V class	FR-BU2-H55K	14	6
	FR-BU2-H75K	38	2

- (5) Crimp terminals for L+ and L- terminals of TE2-1 of converter unit

- (a) Recommended crimp terminals

POINT
<p>● Some crimp terminals may not be mounted depending on their sizes. Make sure to use the recommended ones or equivalent ones.</p>

Converter unit		Brake unit	Number of connected units	Crimp terminal (Manufacturer)	(Note 1) Applicable tool
200 V class	MR-CR55K	FR-BU2-55K	2	38-S6 (JST) (Note 2) R38-6S (NICHIFU) (Note 2)	a
400 V class	MR-CR55K4	FR-BU2-H55K	2	FVD14-6 (JST)	b
		FR-BU2-H75K	2	38-S6 (JST) (Note 2) R38-6S (NICHIFU) (Note 2)	a

- Note 1. Symbols in the applicable tool field indicate applicable tools in (5) (b) of this section.
2. Coat the crimping part with an insulation tube.

- (b) Applicable tool

Symbol	Converter unit-side crimp terminal				
	Crimp terminal	Applicable tool			Manufacturer
		Body	Head	Dice	
a	38-S6	YPT-60-21	YET-60-1	TD-124 TD-112	JST
		YF-1 E-4			
	R38-6S	NOP60 NOM60			NICHIFU
b	FDV14-6	YF-1 E-4	YNE-38	DH-112 DH-122	JST

9. OPTIONS AND PERIPHERAL EQUIPMENT

9.10.4 Dimensions

- (1) FR-BU2-(H) brake unit
FR-BU2-55K/FR-BU2-H55K/FR-BU2-H75K

[Unit: mm]

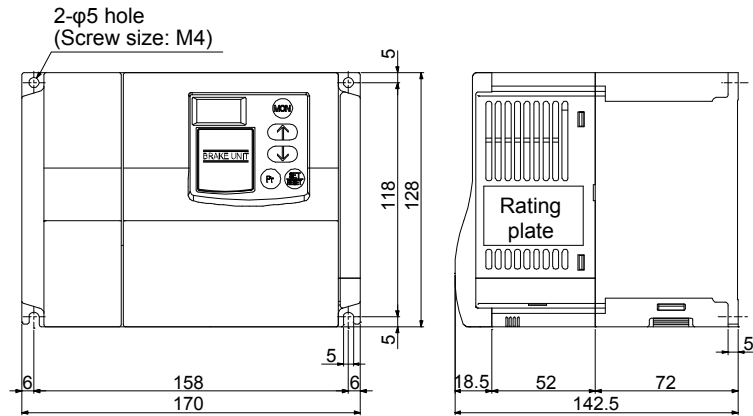

- (2) FR-BR-(H) resistor unit

[Unit: mm]

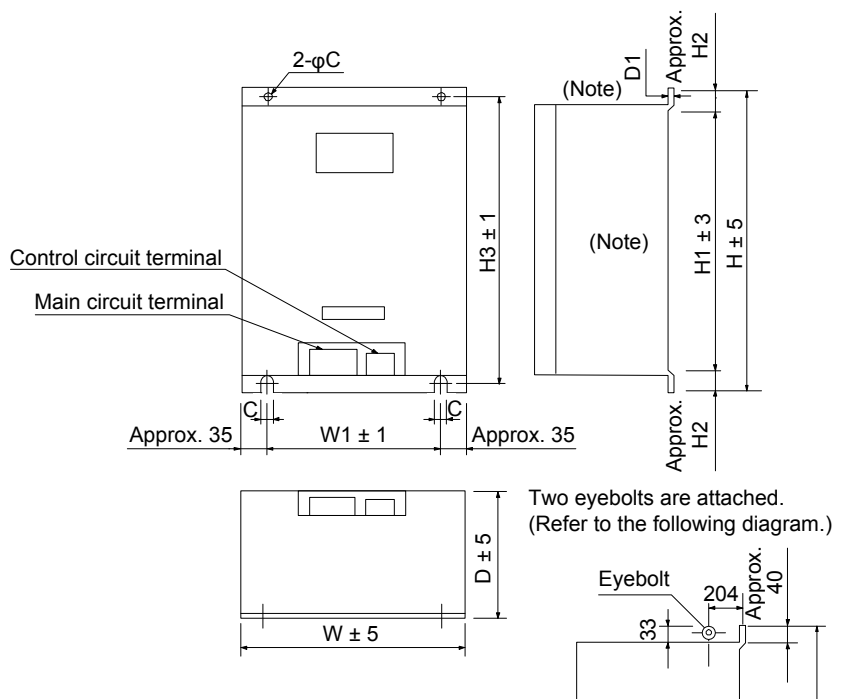

Note. Ventilation ports are provided on both sides and the top. The bottom is open.

Resistor unit		W	W1	H	H1	H2	H3	D	D1	C	Approximate mass [kg]
200 V class	FR-BR-55K	480	410	700	620	40	670	450	3.2	12	70
400 V class	FR-BR-H55K	480	410	700	620	20	670	450	3.2	12	70

9. OPTIONS AND PERIPHERAL EQUIPMENT

(3) MT-BR5-(H) resistor unit

[Unit: mm]

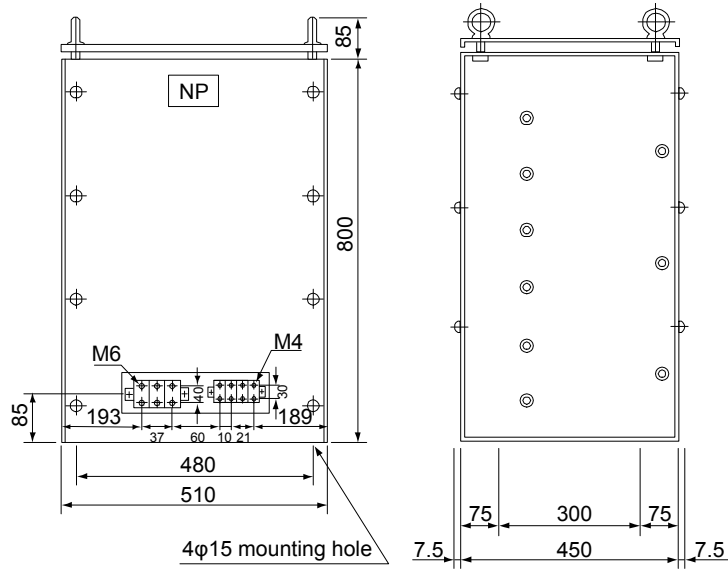

Resistor unit		Resistance	Approximate mass [kg]
200 V class	MT-BR5-55K	2.0 Ω	50
400 V class	MT-BR5-H75K	6.5 Ω	70

10. COMPLIANCE WITH SEMI-F47 STANDARD

10. COMPLIANCE WITH SEMI-F47 STANDARD

POINT
<ul style="list-style-type: none"> ● The control circuit power supply of the converter unit and drive unit can comply with SEMI-F47 standard. However, a back-up capacitor may be necessary for instantaneous power failure in the main circuit power supply depending on the power impedance and operating situation. ● The external dynamic brake cannot be used for compliance with SEMI-F47 standard. Do not assign DB (Dynamic brake interlock). Doing so will cause the drive unit to become servo-off when an instantaneous power failure occurs. ● Be sure to perform actual machine tests and detail checks for power supply instantaneous power failure of SEMI-F47 standard with your equipment.

The following explains the compliance with "SEMI-F47 semiconductor process equipment voltage sag immunity test" of MR-J4 series.

This function enables to avoid triggering [AL. 10 Undervoltage] using the electrical energy charged in the capacitor in case that an instantaneous power failure occurs during operation.

(1) Parameter setting

Setting parameters of the drive unit and converter unit as follows will enable SEMI-F47 function.

Parameter	Setting value	Description
[Pr. PA20] of the drive unit	_ 1 _ _	SEMI-F47 function selection
[Pr. PF25] of the drive unit	200	Set the time [ms] until the occurrence of [AL. 10.1 Voltage drop in the control circuit power].
[Pr. PA17] of the converter unit	_ _ 1 _	SEMI-F47 function selection
[Pr. PA18] of the converter unit	200	Set the time [ms] until the occurrence of [AL. 10 Undervoltage].

Enabling SEMI-F47 function will change operation as follows.

- (a) The voltage will drop in the control circuit power at "Rated voltage × 50% or less". After 200 ms, [AL. 10.1 Voltage drop in the control circuit power] will occur.
- (b) [AL. 10.2 Voltage drop in the main circuit power] will occur when bus voltage is as follows.

Voltages which trigger [AL. 10.2 Voltage drop in the main circuit power]

Drive unit	Bus voltage which triggers alarm
MR-J4-DU30K_(-RJ) MR-J4-DU37K_(-RJ)	200 V DC
MR-J4-DU30K_4(-RJ) MR-J4-DU37K_4(-RJ) MR-J4-DU45K_4(-RJ) MR-J4-DU55K_4(-RJ)	380 V DC

- (c) MBR (Electromagnetic brake interlock) will turn off when [AL. 10.1 Voltage drop in the control circuit power] occurs.

10. COMPLIANCE WITH SEMI-F47 STANDARD

(2) Requirement of SEMI-F47 standard

The following shows the permissible time of instantaneous power failure for instantaneous power failure voltage of SEMI-F47 standard.

Requirement of SEMI-F47 standard

Instantaneous power failure voltage	Permissible time of instantaneous power failure [s]
Rated voltage × 80%	1
Rated voltage × 70%	0.5
Rated voltage × 50%	0.2

(3) Calculation of tolerance against instantaneous power failure

The following shows tolerance against instantaneous power failure when instantaneous power failure voltage is "rated voltage × 50%" and instantaneous power failure time is 200 ms.

Tolerance against instantaneous power failure (instantaneous power failure voltage = rated voltage × 50%, instantaneous power failure time = 200 ms)

Drive unit model	Instantaneous maximum output [W]	Tolerance against instantaneous power failure [W] (voltage drop between lines)
MR-J4-DU30K_	79000	7500
MR-J4-DU37K_	103000	10000
MR-J4-DU30K_4	79000	7500
MR-J4-DU37K_4	103000	7500
MR-J4-DU45K_4	110000	7500
MR-J4-DU55K_4	135000	7500

Instantaneous maximum output means power which drive unit can output in maximum torque at rated speed. You can examine margins to compare the values of following conditions and instantaneous maximum output.

Even if driving at maximum torque with low speed in actual operation, the motor will not drive with the maximum output. This can be handled as a margin.

The following shows the conditions of tolerance against instantaneous power failure.

(a) Delta connection

For the 3-phase (L1/L2/L3) delta connection, an instantaneous power failure occurs in the voltage between a pair of lines (e.g. between L1 and L2) among voltages between three pairs of lines (between L1 and L2, L2 and L3, or L3 and L1).

(b) Star connection

For the 3-phase (L1/L2/L3/neutral point N) star connection, an instantaneous power failure occurs in the voltage between a pair of lines (e.g. between L1 and N) among voltages at six locations, between three pairs of lines (between L1 and L2, L2 and L3, or L3 and L1) and between one of the lines and the neutral point (between L1 and N, L2 and N, or L3 and N).

APPENDIX

App. 1 Peripheral equipment manufacturer (for reference)

Names given in the table are as of August 2015.

Manufacturer	Contact information
DDK	DDK Ltd.
Phoenix Contact	Phoenix Contact GmbH & Co. KG
JST	J.S.T. Mfg. Co., Ltd.
Honda Tsushin Kogyo	HONDA TSUSHIN KOGYO CO., LTD.
3M	3M
NICHIFU	NICHIFU CO., LTD.
Soshin Electric	Soshin Electric Co., Ltd.
Okaya Electric Industries	OKAYA ELECTRIC INDUSTRIES CO., LTD.

App. 2 Compliance with global standards

Converter units and drive units are written as servo amplifiers in app. 2 under certain circumstances.

App. 2.1 Terms related to safety

App. 2.1.1 IEC 61800-5-2 Stop function

STO function (Refer to IEC 61800-5-2: 2007 4.2.2.2 STO.)

MR-J4 servo amplifiers have the STO function. The STO function shuts down energy to servo motors, thus removing torque. This function electronically cuts off power supply in the servo amplifier.

App. 2.2 About safety

This section explains safety of users and machine operators. Please read the chapter carefully before mounting the equipment.

App. 2.2.1 Professional engineer

Only professional engineers should mount MR-J4 servo amplifiers.

Here, professional engineers should meet the all conditions below.

- (1) Persons who took a proper engineering training or qualified persons who are engaged in electrical equipment.
Check if applicable technical training is available at your local Mitsubishi Electric office. Contact your local sales office for schedules and locations.
- (2) A person who can access to operating manuals for the protective devices (e.g. light curtain) connected to the safety control system. A person who have read and familiarized himself/herself with the manuals.

App. 2.2.2 Applications of the devices

MR-J4 servo amplifiers comply with the following standards.

ISO/EN ISO 13849-1 category 3 PL e, IEC/EN 62061 SIL CL 3, IEC/EN 61800-5-2 SIL 3 (STO) IEC/EN 61800-5-1, IEC/EN 61800-3, IEC/EN 60204-1

MR-J4 servo amplifiers can be used with the MR-J3-D05 safety logic unit, or safety PLCs.

APPENDIX

App.2.2.3 Correct use

Always use the MR-J4 servo amplifiers within specifications (voltage, temperature, etc. Refer to section 1.2.). Mitsubishi Electric Co. accepts no claims for liability if the equipment is used in any other way or if modifications are made to the device, even in the context of mounting and installation.

 **WARNING** ● It takes 20 minutes maximum for capacitor discharging. Do not touch the unit and terminals immediately after power off.

(1) Selection of peripheral equipment and wire

The followings are selected based on IEC/EN 61800-5-1, UL 508C, and CSA C22.2 No.14.

(a) Local wiring and crimping tool

Use only copper wires or copper bus bars for wiring. The following table shows the stranded wire sizes [AWG] and the crimp terminal symbols rated at 75 °C/60 °C.

Table App. 2.1 Recommended wire (Note 1)

Drive unit	Converter unit	75 °C/60 °C stranded wire [AWG] (Note 2)			
		L1/L2/L3 ⊕	L11/L21	P2/C	U/V/W/⊕ (Note 3)
MR-J4-DU30K_	MR-CR55K	1: c/1/0: d	14: g/14: g	10: a/10: a	2/0: d/2/0: d
MR-J4-DU37K_		2/0: d (Note 4)/-: -			2/0: d (Note 4)/-: -
MR-J4-DU30K_4	MR-CR55K4	4: e/3: f			3: f/2: f
MR-J4-DU37K_4		2: f/1: c			2: f/1: c
MR-J4-DU45K_4		2: c/2: c			1/0: d/1/0: d
MR-J4-DU55K_4		2: c/1/0: d			1/0: d/2/0: d

- Note
1. To connect these models to a terminal block, be sure to use the screws that come with the terminal block.
 2. Alphabets in the table indicate crimping tools. For crimp terminals and applicable tools, refer to table App. 2.2.
 3. Select wire sizes depending on the rated output of the servo motors. The values in the table are sizes based on rated output of the servo amplifiers.
 4. This wire size applies only to the units with rated current less than 175 A.

Table App. 2.2 Recommended crimp terminal

Symbol	Servo amplifier-side crimp terminals		Manufacturer
	Crimp terminal (Note 2)	Applicable tool	
a	FVD5.5-10	YNT-1210S	JST (J.S.T. Mfg. Co., Ltd.)
b	FVD22-10	YF-1/E-4	
c (Note 1)	R38-10	YPT-60-21	
		YF-1/E-4	
d (Note 1)	R60-10	YPT-60-21	
		YF-1/E-4	
e	FVD22-8	YF-1/E-4	
f (Note 1)	R38-8	YPT-60-21	
		YF-1/E-4	
g	FVD2-4	YNT-1614	

- Note
1. Coat the crimping part with an insulation tube.
 2. Some crimp terminals may not be mounted depending on their sizes. Make sure to use the recommended ones or equivalent ones.

APPENDIX

(b) Selection example of MCCB and fuse

Use a fuse (T class) or the molded-case circuit breaker (UL 489 Listed MCCB) indicated in the table below. The T class fuses and molded-case circuit breakers in the table are selected examples based on rated I/O of the servo amplifiers. When you select a smaller capacity servo motor to connect it to the servo amplifier, you can also use smaller capacity T class fuses or molded-case circuit breaker than ones in the table. For selecting ones other than Class T fuses and molded-case circuit breakers below, refer to section 9.5.

Converter unit	Drive unit	Molded-case circuit breaker (240 V AC)	Fuse (300 V)
MR-CR55K	MR-J4-DU30K_	NF225-CWU-150A (225 A frame 150 A)	250 A
	MR-J4-DU37K_	NF225-CWU-175A (225 A frame 175 A)	300 A

Converter unit	Drive unit	Molded-case circuit breaker (480 V AC)	Fuse (600 V)
MR-CR55K4	MR-J4-DU30K_4	NF100-HRU-75A (100 A frame 75 A)	125 A
	MR-J4-DU37K_4	NF100-HRU-100A (100 A frame 100 A)	150 A
	MR-J4-DU45K_4	NF100-HRU-100A (100 A frame 100 A)	175 A
	MR-J4-DU55K_4	NF125-SVU-125A (125 A frame 125 A)	200 A

(c) Power supply

This servo amplifier can be used on the condition of overvoltage category III set forth in IEC/EN 60664-1. For the interface power supply, use an external 24 V DC power supply with reinforced insulation on I/O terminals.

(d) Grounding

To prevent an electric shock, always connect the protective earth (PE) terminal (marked ⊕) of the servo amplifier to the protective earth (PE) of the cabinet. Do not connect two grounding cables to the same protective earth (PE) terminal. Always connect cables to the terminals one-to-one. This product can cause a DC current in the protective earthing conductor. Where a residual current-operated protective (RCD: earth-leakage current breaker) device is used for protection in case of direct or indirect contact, only an RCD of Type B is allowed on the supply side of this product.

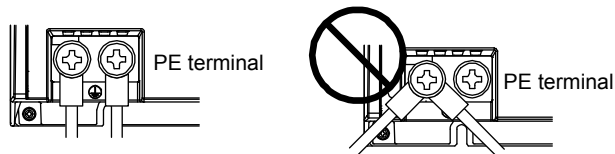

(2) EU compliance

The MR-J4 servo amplifiers are designed to comply with the following directions to meet requirements for mounting, using, and periodic technical inspections: Machinery directive (2006/42/EC), EMC directive (2004/108/EC), and Low-voltage directive (2006/95/EC).

APPENDIX

(a) EMC requirement

MR-J4 servo amplifiers comply with category C3 in accordance with EN 61800-3. As for I/O wires (max. length 10 m. However, 3 m for STO cable for CN8.) and encoder cables (max. length 50 m), use shielded wires and ground the shields. Install an EMC filter and surge protector on the primary side of the servo amplifier. In addition, use a line noise filter for outputs of the servo amplifiers. The following shows recommended products.

EMC filter: Soshin Electric HF3000A-UN series (200 V class), TF3000C-TX series (400 V class)

Surge protector: Okaya Electric Industries RSPD-250-U4 series

Line noise filter: Mitsubishi Electric FR-BIF

MR-J4 Series are not intended to be used on a low-voltage public network which supplies domestic premises; Radio frequency interference is expected if used on such a network. The installer shall provide a guide for Installation and use, including recommended mitigation devices. To avoid the risk of crosstalk to signal cables, the installation instructions shall either recommend that the power interface cable be segregated from signal cables.

(b) For Declaration of Conformity (DoC)

Hereby, MITSUBISHI ELECTRIC EUROPE B.V., declares that the servo amplifiers are in compliance with the necessary requirements and standards (2006/42/EC, 2004/108/EC and 2006/95/EC). For the copy of Declaration of Conformity, contact your local sales office.

(3) USA/Canada compliance

This servo amplifier is designed in compliance with UL 508C and CSA C22.2 No.14.

(a) Installation

The minimum cabinet size is 150% of each MR-J4 servo amplifier's volume. Also, design the cabinet so that the ambient temperature in the cabinet is 55 °C or less. The servo amplifier must be installed in a metal cabinet. Additionally, mount the servo amplifier on a cabinet that the protective earth based on the standard of IEC/EN 60204-1 is correctly connected. For environment, the units should be used in open type (UL 50) and overvoltage category shown in table in App. 2.8. The servo amplifier needs to be installed at or below of pollution degree 2. For connection, use only copper wires.

(b) Short-circuit current rating (SCCR)

Suitable For Use On A Circuit Capable Of Delivering Not More Than 100 kA rms Symmetrical Amperes, 500 Volts Maximum.

(c) Overload protection characteristics

The MR-J4 servo amplifiers have servo motor overload protective function. (It is set on the basis (full load current) of 120% rated current of the servo amplifier.)

(d) Over-temperature protection for motor

Motor Over temperature sensing is not provided by the drive.

Integral thermal protection(s) is necessary for motor and refer to App. 2.4 for the proper connection.

(e) Branch circuit protection

For installation in United States, branch circuit protection must be provided, in accordance with the National Electrical Code and any applicable local codes.

For installation in Canada, branch circuit protection must be provided, in accordance with the Canada Electrical Code and any applicable provincial codes.

APPENDIX

(4) South Korea compliance

This product complies with the Radio Wave Law (KC mark) Please note the following to use the product.
이 기기는 업무용 (A급) 전자파적합기기로서 판매자 또는 사용자는 이 점을 주의하시기 바라며,
가정외의 지역에서 사용하는 것을 목적으로 합니다.

(The product is for business use (Class A) and meets the electromagnetic compatibility requirements.

The seller and the user must note the above point, and use the product in a place except for home.)

In addition, use an EMC filter, surge protector, ferrite core, and line noise filter on the primary side for inputs. Use a ferrite core and line noise filter for outputs. Use a distance greater than 30 m between the product and third party sensitive radio communications.

App. 2.2.4 General cautions for safety protection and protective measures

Observe the following items to ensure proper use of the MELSERVO MR-J4 servo amplifiers.

- (1) For safety components and installing systems, only qualified personnel and professional engineers should perform.
- (2) When mounting, installing, and using the MR-J4 servo amplifier, always observe standards and directives applicable in the country.
- (3) The item about noises of the test notices in the manuals should be observed.

App. 2.2.5 Residual risk

- (1) Be sure that all safety related switches, relays, sensors, etc., meet the required safety standards.
- (2) Perform all risk assessments and safety level certification to the machine or the system as a whole.
- (3) If the upper and lower power modules in the servo amplifier are shorted and damaged simultaneously, the servo motor may make a half revolution at a maximum.
- (4) Only qualified personnel are authorized to install, start-up, repair or adjust the machines in which these components are installed. Only trained engineers should install and operate the equipment. (ISO 13849-1 Table F.1 No.5)
- (5) Separate the wiring for safety observation function from other signal wirings. (ISO 13849-1 Table F.1 No.1)
- (6) Protect the cables with appropriate ways (routing them in a cabinet, using a cable guard, etc.).
- (7) Keep the required clearance/creepage distance depending on voltage you use.

APPENDIX

App. 2.2.6 Disposal

Disposal of unusable or irreparable devices should always occur in accordance with the applicable country-specific waste disposal regulations. (Example: European Waste 16 02 14)

App. 2.2.7 Lithium battery transportation

To transport lithium batteries, take actions to comply with the instructions and regulations such as the United Nations (UN), the International Civil Aviation Organization (ICAO), and the International Maritime Organization (IMO).

The batteries (MR-BAT6V1SET, MR-BAT6V1, and MR-BAT6V1BJ) are assembled batteries from two batteries (lithium metal battery CR17335A) which are not subject to the dangerous goods (Class 9) of the UN Recommendations.

App. 2.3 Mounting/dismounting

Installation direction and clearances

 CAUTION	<ul style="list-style-type: none">● The devices must be installed in the specified direction. Not doing so may cause a malfunction.● Mount the servo amplifier on a cabinet which meets IP54 in the correct vertical direction to maintain pollution degree 2.
--	---

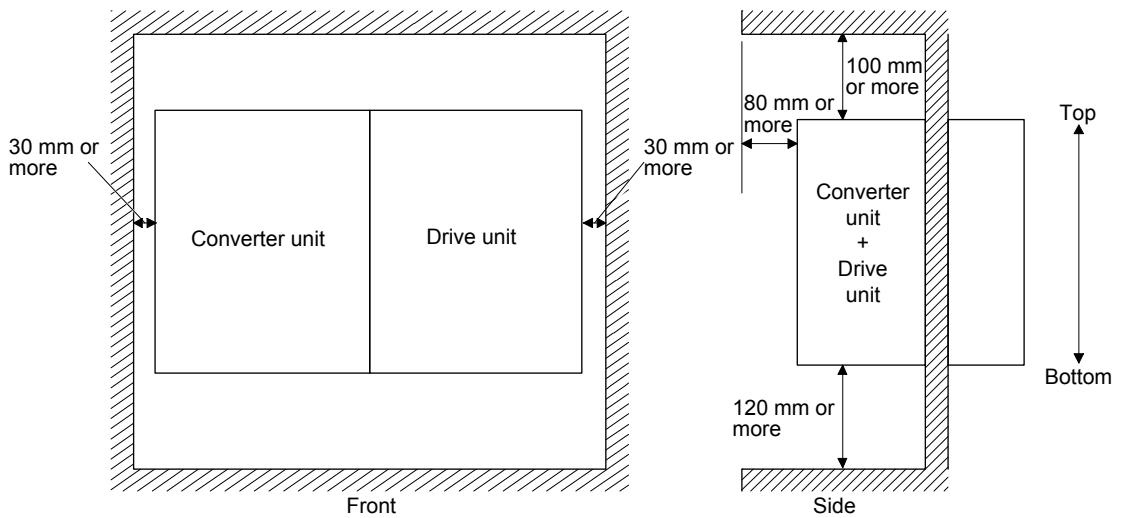

APPENDIX

App. 2.5 Signals

App. 2.5.1 Signal

The following shows MR-J4-DU30KB signals as a typical example. For other servo amplifiers, refer to each servo amplifier instruction manual.

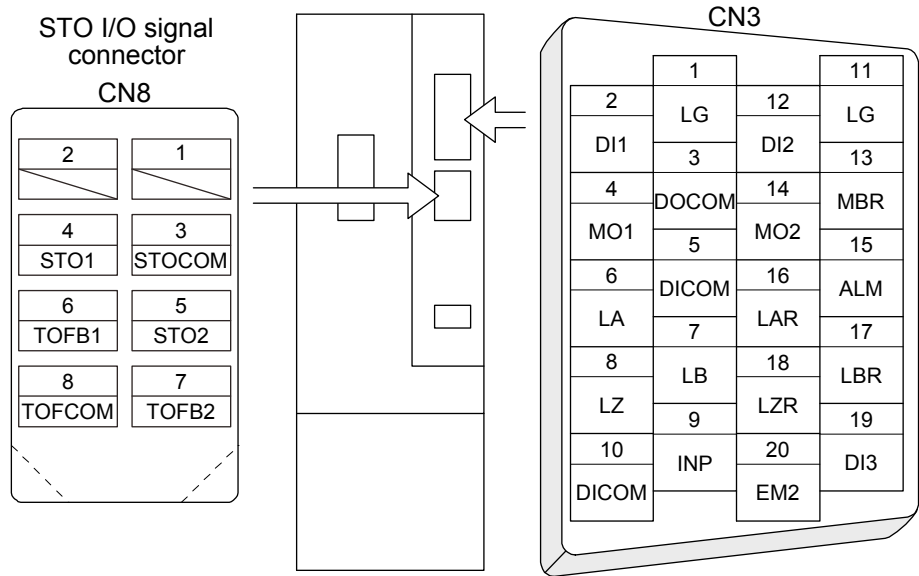

App. 2.5.2 I/O device

Input device

Symbol	Device	Connector	Pin No.
EM2	Forced stop 2	CN3	20
STOCOM	Common terminal for input signals STO1/STO2	CN8	3
STO1	STO1 state input		4
STO2	STO2 state input		5

Output device

Symbol	Device	Connector	Pin No.
TOFCOM	Common terminal for monitor output signal in STO state	CN8	8
TOFB1	Monitor output signal in STO1 state		6
TOFB2	Monitor output signal in STO2 state		7

Power supply

Symbol	Device	Connector	Pin No.
DICOM	Digital I/F power supply input	CN3	5, 10
DOCOM	Digital I/F common		3
SD	Shield		Plate

APPENDIX

App. 2.6 Maintenance and service

 WARNING	● To avoid an electric shock, only qualified personnel should attempt inspections. For repair and parts replacement, contact your local sales office.
--	--

App. 2.6.1 Inspection items

It is recommended that the following points periodically be checked.

(1) Check for loose terminal block screws. Retighten any loose screws.

Drive unit/converter unit	Tightening torque: [N•m]														
	L1	L2	L3	P1	P2	C	L+	L-	L11	L21	U	V	W	PE	
MR-J4-DU30K_/MR-J4-DU37K_/MR-J4-DU45K_4/MR-J4-DU55K_4	/						3.0		1.2		12.0				
MR-J4-DU30K_/MR-J4-DU37K_4											6.0				
MR-J4-CR55K(4)	12.0										12.0				

(2) Check servo motor bearings, brake section, etc. for unusual noise.

(3) Check the cables and the like for scratches or cracks. Perform periodic inspection according to operating conditions.

(4) Check that the connectors are securely connected to the servo motor.

(5) Check that the wires are not coming out from the connector.

(6) Check for dust accumulation on the servo amplifier.

(7) Check for unusual noise generated from the servo amplifier.

(8) Check the servo motor shaft and coupling for connection.

App. 2.6.2 Parts having service lives

Service lives of the following parts are listed below. However, the service life varies depending on operating methods and environment. If any fault is found in the parts, they must be replaced immediately regardless of their service lives. For parts replacement, please contact your local sales office.

Part name	Life guideline
Smoothing capacitor	(Note 3) 10 years
Relay	Number of power-on, forced stop and controller forced stop times: 100,000 times Number of on and off for STO: 100,000 times
Cooling fan	10,000 hours to 30,000 hours (2 years to 3 years)
(Note 1) Battery backup time	Approximately 20,000 hours (equipment power supply: off, ambient temperature: 20 °C)
(Note 2) Battery life	5 years from date of manufacture

- Note
- The time is for using MR-J4 1-axis servo amplifier with a rotary servo motor using MR-BAT6V1SET or MR-BAT6V1BJ. For details and other battery backup time, refer to each instruction manual.
 - Quality of the batteries degrades by the storage condition. The battery life is 5 years from the production date regardless of the connection status.
 - The characteristic of smoothing capacitor is deteriorated due to ripple currents, etc. The life of the capacitor greatly depends on ambient temperature and operating conditions. The capacitor will be the end of its life in 10 years of continuous operation in air conditioned environment (40 °C surrounding air temperature or less for use at the maximum 1000 m above sea level, 30 °C or less for over 1000 m to 2000 m).

APPENDIX

App. 2.7 Transportation and storage

 CAUTION	● Transport the products correctly according to their mass.
	● Stacking in excess of the limited number of product packages is not allowed.
	● Do not hold the front cover to transport the servo amplifier. Otherwise, it may drop.
	● For detailed information on transportation and handling of the battery, refer to the servo amplifier instruction manual.
	● Install the product in a load-bearing place of servo amplifier and servo motor in accordance with the instruction manual.
	● Do not get on or put heavy load on the equipment.

When you keep or use it, please fulfill the following environment.

Item		Environment
Ambient temperature	Operation [°C]	0 to 55 Class 3K3 (IEC/EN 60721-3-3)
	Transportation (Note) [°C]	-20 to 65 Class 2K4 (IEC/EN 60721-3-2)
	Storage (Note) [°C]	-20 to 65 Class 1K4 (IEC/EN 60721-3-1)
Ambient humidity	Operation, transportation, storage	5 %RH to 90 %RH
Vibration resistance	Test condition	10 Hz to 57 Hz with constant amplitude of 0.075 mm 57 Hz to 150 Hz with constant acceleration of 9.8 m/s ² to IEC/EN 61800-5-1 (Test Fc of IEC 60068-2-6)
	Operation	5.9 m/s ²
	Transportation (Note)	Class 2M3 (IEC/EN 60721-3-2)
	Storage	Class 1M2 (IEC/EN 60721-3-2)
Pollution degree		2
IP rating		IP20 (IEC/EN 60529), Terminal block IP00 Open type (UL 50)
Altitude	Operation, storage	2000 m or less above sea level
	Transportation	10000 m or less above sea level

Note. In regular transport packaging

App. 2.8 Technical data

App. 2.8.1 Converter unit

Item		MR-CR55K	MR-CR55K4
Output	Rated voltage	270 V DC to 324 V DC	513 V DC to 648 V DC
	Rated current [A]	215.9	113.8
Power supply	Main circuit (line voltage)	3-phase 200 V AC to 240 V AC, 50 Hz/60 Hz, 191.3 A	3-phase 380 V AC to 480 V AC, 50 Hz/60 Hz, 100.7 A
	Control circuit (line voltage)	1-phase 200 V AC to 240 V AC, 50 Hz/60 Hz, 0.3 A	1-phase 380 V AC to 480 V AC, 50 Hz/60 Hz, 0.2 A
	Interface (SELV)	24 V DC ± 10% (required current capacity: 150 mA)	
Pollution degree		2 (IEC/EN 60664-1)	
Overvoltage category		3-phase 200 V AC/400 V AC: III (IEC/EN 60664-1)	
Protective class		I (IEC/EN 61800-5-1)	
Short-circuit current rating (SCCR)		100 kA	

APPENDIX

App. 2.8.2 Drive unit

Item		MR-J4-DU30K_	MR-J4-DU37K_	MR-J4-DU30K_4	MR-J4-DU37K_4	MR-J4-DU45K_4	MR-J4-DU55K_4
Output	Rated voltage	3-phase 170 V AC, 360 Hz			3-phase 323 V AC, 360 Hz		
	Rated current [A]	174	204	87	102	131	143
Power supply	Main circuit	The main circuit power of the drive unit is supplied by the converter unit.					
	Control circuit (line voltage)	1-phase 200 V AC to 240 V AC, 50 Hz/60 Hz, 0.3 A			1-phase 380 V AC to 480 V AC, 50 Hz/60 Hz, 0.2 A		
	Interface (SELV)	24 V DC \pm 10% (required current capacity: MR-J4-DU_A_, 500 mA; MR-J4-DU_B_, 300 mA)					
Control method		Sine-wave PWM control, current control method					
Safety observation function (STO) IEC/EN 61800-5-2		EN ISO 13849-1 category 3 PL e, IEC 61508 SIL 3, EN 62061 SIL CL3, EN 61800-5-2 SIL 3					
Mean time to dangerous failure		MTTFd \geq 100 [years] (314a)					
Effectiveness of fault monitoring of a system or subsystem		DC = 97.6 [%]					
Average probability of dangerous failures per hour		PFH = 6.4×10^{-9} [1/h]					
Mission time		TM = 20 [years]					
Response performance		8 ms or less (STO input off \rightarrow energy shut off)					
Pollution degree		2 (IEC/EN 60664-1)					
Overvoltage category		3-phase 200 V AC/400 V AC: III (IEC/EN 60664-1)					
Protective class		I (IEC/EN 61800-5-1)					
Short-circuit current rating (SCCR)		100 kA					

App. 2.8.3 Dimensions

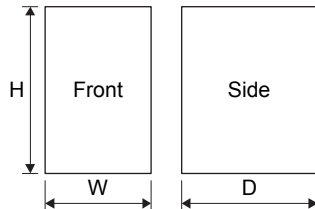

Converter unit/drive unit	Variable dimension table [mm]			Mass [kg]
	W	H	D	
MR-CR55K(4)	300	380	300	22
MR-J4-DU30K_/MR-J4-DU37K_	300	380	300	21
MR-J4-DU30K_4/MR-J4-DU37K_4	240	380	300	16
MR-J4-DU45K_4/MR-J4-DU55K_4	300	380	300	21

APPENDIX

App. 2.8.4 Mounting hole process drawing

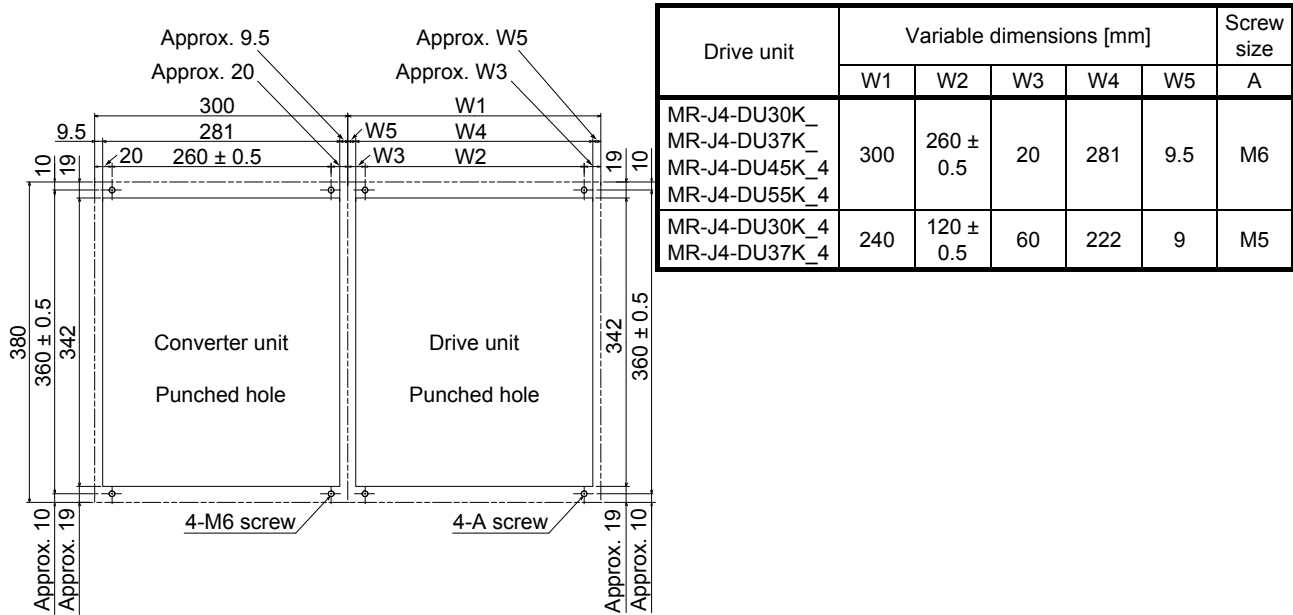

App. 2.9 Check list for user documentation



MR-J4-DU/MR-CR installation checklist for manufacturer/installer

The following items must be satisfied by the initial test operation at least. The manufacturer/installer must be responsible for checking the standards in the items.

Maintain and keep this checklist with related documents of machines to use this for periodic inspection.

1. Is it based on directive/standard applied to the machine? Yes [], No []
2. Is directive/standard contained in Declaration of Conformity (DoC)? Yes [], No []
3. Does the protection instrument conform to the category required? Yes [], No []
4. Are electric shock protective measures (protective class) effective? Yes [], No []
5. Is the STO function checked (test of all the shut-off wiring)? Yes [], No []

Checking the items will not be instead of the first test operation or periodic inspection by professional engineers.

REVISION

*The manual number is given on the bottom left of the back cover.

Print Data	*Manual Number	Revision
Jan. 2015	SH(NA)030153-A	First edition
Aug. 2015	SH(NA)030153-B	<p>Altitude of 2000 m above sea level is disclosed.</p> <p>Safety Instructions</p> <p>4. Additional instructions The environment is changed.</p> <p>Relevant manuals The part of table is changed.</p> <p>Section 1.1.1 The diagram is partially changed.</p> <p>Section 1.1 The note is partially changed.</p> <p>Section 1.2.1 The part of table is changed.</p> <p>Section 1.2.2 (1) (a) The table and the note are partially changed.</p> <p>Section 1.2.2 (1) (b) The table and the note are partially changed.</p> <p>Section 1.2.2 (2) (a) The table and the note are partially changed.</p> <p>Section 1.2.2 (2) (b) The table and the note are partially changed.</p> <p>Section 1.4 (2) (b) The diagram is changed.</p> <p>Section 1.5.1 (1) The part of table is changed.</p> <p>Section 1.5.1 (2) (a) 1) a) The part of table is changed.</p> <p>Section 1.5.1 (2) (a) 2) a) The part of table is changed.</p> <p>Section 1.6 The note is changed.</p> <p>Section 2.5 Added.</p> <p>Section 3.1.2 (1) (a) The note is partially changed.</p> <p>Section 3.1.2 (1) (b) The note is partially changed.</p> <p>Section 3.1.2 (2) (a) The note is partially changed.</p> <p>Section 3.1.2 (2) (b) The note is partially changed.</p> <p>Section 3.3.2 (1) The diagram is partially changed.</p> <p>Section 6.2 The sentences are partially changed.</p> <p>Section 6.2.1 (2) The sentences are partially changed.</p> <p>Section 6.2.2 The table and the note are partially changed.</p> <p>Section 6.2.3 The part of table is changed.</p> <p>Section 9.3.2 The note is partially changed.</p> <p>Section 9.5 (1) The caution and the note are added.</p> <p>Section 9.5 (2) The sentences are changed.</p> <p>Section 9.10.3 (1) (a) The note is partially changed.</p> <p>Section 9.10.3 (1) (b) The note is partially changed.</p> <p>Section 9.10.3 (2) (a) 1) The note is partially changed.</p> <p>Section 9.10.3 (2) (a) 2) The note is partially changed.</p> <p>Section 9.10.3 (2) (b) 1) The note is partially changed.</p> <p>Section 9.10.3 (2) (b) 2) The note is partially changed.</p> <p>Section 9.10.3 (3) The diagram is partially changed.</p> <p>App. 2 Partially changed.</p>

This manual confers no industrial property rights or any rights of any other kind, nor does it confer any patent licenses. Mitsubishi Electric Corporation cannot be held responsible for any problems involving industrial property rights which may occur as a result of using the contents noted in this manual.

Country/Region	Sales office	Tel/Fax
USA	MITSUBISHI ELECTRIC AUTOMATION, INC. 500 Corporate Woods Parkway, Vernon Hills, IL 60061, U.S.A.	Tel : +1-847-478-2100 Fax : +1-847-478-2253
Mexico	MITSUBISHI ELECTRIC AUTOMATION, INC. Mexico Branch Mariano Escobedo #69, Col. Zona Industrial, Tlalnepantla Edo, C.P.54030, Mexico	Tel : +52-55-3067-7500 Fax : -
Brazil	MITSUBISHI ELECTRIC DO BRASIL COMÉRCIO E SERVIÇOS LTDA. Rua Jussara, 1750- Bloco B Anexo, Jardim Santa Cecilia, CÉP 06465-070, Barueri - SP, Brasil	Tel : +55-11-4689-3000 Fax : +55-11-4689-3016
Germany	MITSUBISHI ELECTRIC EUROPE B.V. German Branch Gothaer Strasse 8, D-40880 Ratingen, Germany	Tel : +49-2102-486-0 Fax : +49-2102-486-1120
UK	MITSUBISHI ELECTRIC EUROPE B.V. UK Branch Travellers Lane, Hatfield, Hertfordshire, AL10 8XB, U.K.	Tel : +44-1707-28-8780 Fax : +44-1707-27-8695
Italy	MITSUBISHI ELECTRIC EUROPE B.V. Italian Branch Centro Direzionale Colleoni - Palazzo Sirio Viale Colleoni 7, 20864 Agrate Brianza (Milano) Italy	Tel : +39-039-60531 Fax : +39-039-6053-312
Spain	MITSUBISHI ELECTRIC EUROPE, B.V. Spanish Branch Carretera de Rubí, 76-80-Apdo. 420, 08173 Sant Cugat del Vallés (Barcelona), Spain	Tel : +34-935-65-3131 Fax : +34-935-89-1579
France	MITSUBISHI ELECTRIC EUROPE B.V. French Branch 25, Boulevard des Bouvets, F-92741 Nanterre Cedex, France	Tel : +33-1-55-68-55-68 Fax : +33-1-55-68-57-57
Czech Republic	MITSUBISHI ELECTRIC EUROPE B.V. Czech Branch Avenir Business Park, Radlicka 751/113e, 158 00 Praha5, Czech Republic	Tel : +420-251-551-470 Fax : +420-251-551-471
Poland	MITSUBISHI ELECTRIC EUROPE B.V. Polish Branch Krakowska 50, 32-083 Balice, Poland	Tel : +48-12-630-47-00 Fax : +48-12-630-47-01
Russia	MITSUBISHI ELECTRIC EUROPE B.V. Russian Branch St. Petersburg office Piskarevsky pr. 2, bld 2, lit "Sch", BC "Benua", office 720; RU-195027 St. Petersburg, Russia	Tel : +7-812-633-3497 Fax : +7-812-633-3499
Sweden	MITSUBISHI ELECTRIC EUROPE B.V. (Scandinavia) Fjellievägen 8, SE-22736 Lund, Sweden	Tel : +46-8-625-10-00 Fax : +46-46-39-70-18
Turkey	MITSUBISHI ELECTRIC TURKEY A.Ş Ümraniye Branch Şerifali Mahallesi Nutuk Sokak No:5, TR-34775 Ümraniye, İstanbul, Turkey	Tel : +90-216-526-3990 Fax : +90-216-526-3995
UAE	MITSUBISHI ELECTRIC EUROPE B.V. Dubai Branch Dubai Silicon Oasis, P.O.BOX 341241, Dubai, U.A.E.	Tel : +971-4-3724716 Fax : +971-4-3724721
South Africa	ADROIT TECHNOLOGIES 20 Waterford Office Park, 189 Witkoppen Road, Fourways, Johannesburg, South Africa	Tel : +27-11-658-8100 Fax : +27-11-658-8101
China	MITSUBISHI ELECTRIC AUTOMATION (CHINA) LTD. No.1386 Hongqiao Road, Mitsubishi Electric Automation Center, Shanghai, China	Tel : +86-21-2322-3030 Fax : +86-21-2322-3000
Taiwan	SETSUYO ENTERPRISE CO., LTD. 6F, No.105, Wugong 3rd Road, Wugu District, New Taipei City 24889, Taiwan, R.O.C.	Tel : +886-2-2299-2499 Fax : +886-2-2299-2509
Korea	MITSUBISHI ELECTRIC AUTOMATION KOREA CO., LTD. 7F-9F, Gangseo Hangang Xi-tower A, 401, Yangcheon-ro, Gangseo-Gu, Seoul 157-801, Korea	Tel : +82-2-3660-9510 Fax : +82-2-3664-8372/8335
Singapore	MITSUBISHI ELECTRIC ASIA PTE. LTD. 307, Alexandra Road, Mitsubishi Electric Building, Singapore 159943	Tel : +65-6473-2308 Fax : +65-6476-7439
Thailand	MITSUBISHI ELECTRIC FACTORY AUTOMATION (THAILAND) CO., LTD. 12th Floor, SV.City Building, Office Tower 1, No. 896/19 and 20 Rama 3 Road, Kwaeng Bangpongpan, Khet Yannawa, Bangkok 10120, Thailand	Tel : +66-2682-6522 to 6531 Fax : +66-2682-6020
Indonesia	PT. MITSUBISHI ELECTRIC INDONESIA Gedung Jaya 11th Floor, JL. MH. Thamrin No.12, Jakarta Pusat 10340, Indonesia	Tel : +62-21-3192-6461 Fax : +62-21-3192-3942
Vietnam	MITSUBISHI ELECTRIC VIETNAM COMPANY LIMITED Unit 01-04, 10th Floor, Vincom Center, 72 Le Thanh Ton Street, District 1, Ho Chi Minh City, Vietnam	Tel : +84-8-3910-5945 Fax : +84-8-3910-5947
India	MITSUBISHI ELECTRIC INDIA PVT. LTD. Pune Branch Emerald House, EL -3, J Block, M.I.D.C Bhosari, Pune - 411026, Maharashtra, India	Tel : +91-20-2710-2000 Fax : +91-20-2710-2100
Australia	MITSUBISHI ELECTRIC AUSTRALIA PTY. LTD. 348 Victoria Road, P.O. Box 11, Rydalmere, N.S.W 2116, Australia	Tel : +61-2-9684-7777 Fax : +61-2-9684-7245

MELSERVO is a trademark or registered trademark of Mitsubishi Electric Corporation in Japan and/or other countries.
All other product names and company names are trademarks or registered trademarks of their respective companies.

Warranty

1. Warranty period and coverage

We will repair any failure or defect hereinafter referred to as "failure" in our FA equipment hereinafter referred to as the "Product" arisen during warranty period at no charge due to causes for which we are responsible through the distributor from which you purchased the Product or our service provider. However, we will charge the actual cost of dispatching our engineer for an on-site repair work on request by customer in Japan or overseas countries. We are not responsible for any on-site readjustment and/or trial run that may be required after a defective unit are repaired or replaced.

[Term]

The term of warranty for Product is twelve (12) months after your purchase or delivery of the Product to a place designated by you or eighteen (18) months from the date of manufacture whichever comes first ("Warranty Period"). Warranty period for repaired Product cannot exceed beyond the original warranty period before any repair work.

[Limitations]

- (1) You are requested to conduct an initial failure diagnosis by yourself, as a general rule.
It can also be carried out by us or our service company upon your request and the actual cost will be charged. However, it will not be charged if we are responsible for the cause of the failure.
- (2) This limited warranty applies only when the condition, method, environment, etc. of use are in compliance with the terms and conditions and instructions that are set forth in the instruction manual and user manual for the Product and the caution label affixed to the Product.
- (3) Even during the term of warranty, the repair cost will be charged on you in the following cases;
 - (i) a failure caused by your improper storing or handling, carelessness or negligence, etc., and a failure caused by your hardware or software problem
 - (ii) a failure caused by any alteration, etc. to the Product made on your side without our approval
 - (iii) a failure which may be regarded as avoidable, if your equipment in which the Product is incorporated is equipped with a safety device required by applicable laws and has any function or structure considered to be indispensable according to a common sense in the industry
 - (iv) a failure which may be regarded as avoidable if consumable parts designated in the instruction manual, etc. are duly maintained and replaced
 - (v) any replacement of consumable parts (battery, fan, smoothing capacitor, etc.)
 - (vi) a failure caused by external factors such as inevitable accidents, including without limitation fire and abnormal fluctuation of voltage, and acts of God, including without limitation earthquake, lightning and natural disasters
 - (vii) a failure generated by an unforeseeable cause with a scientific technology that was not available at the time of the shipment of the Product from our company
 - (viii) any other failures which we are not responsible for or which you acknowledge we are not responsible for

2. Term of warranty after the stop of production

- (1) We may accept the repair at charge for another seven (7) years after the production of the product is discontinued. The announcement of the stop of production for each model can be seen in our Sales and Service, etc.
- (2) Please note that the Product (including its spare parts) cannot be ordered after its stop of production.

3. Service in overseas countries

Our regional FA Center in overseas countries will accept the repair work of the Product. However, the terms and conditions of the repair work may differ depending on each FA Center. Please ask your local FA center for details.

4. Exclusion of responsibility for compensation against loss of opportunity, secondary loss, etc.

Whether under or after the term of warranty, we assume no responsibility for any damages arisen from causes for which we are not responsible, any losses of opportunity and/or profit incurred by you due to a failure of the Product, any damages, secondary damages or compensation for accidents arisen under a specific circumstance that are foreseen or unforeseen by our company, any damages to products other than the Product, and also compensation for any replacement work, readjustment, start-up test run of local machines and the Product and any other operations conducted by you.

5. Change of Product specifications

Specifications listed in our catalogs, manuals or technical documents may be changed without notice.

6. Application and use of the Product

- (1) For the use of our General-Purpose AC Servo, its applications should be those that may not result in a serious damage even if any failure or malfunction occurs in General-Purpose AC Servo, and a backup or fail-safe function should operate on an external system to General-Purpose AC Servo when any failure or malfunction occurs.
- (2) Our General-Purpose AC Servo is designed and manufactured as a general purpose product for use at general industries. Therefore, applications substantially influential on the public interest for such as atomic power plants and other power plants of electric power companies, and also which require a special quality assurance system, including applications for railway companies and government or public offices are not recommended, and we assume no responsibility for any failure caused by these applications when used
In addition, applications which may be substantially influential to human lives or properties for such as airlines, medical treatments, railway service, incineration and fuel systems, man-operated material handling equipment, entertainment machines, safety machines, etc. are not recommended, and we assume no responsibility for any failure caused by these applications when used. We will review the acceptability of the abovementioned applications, if you agree not to require a specific quality for a specific application. Please contact us for consultation.

MODEL	MR-J4-DU-(RJ)MR-CR-55K INSTRUCTIONMANUAL
MODEL CODE	1CW851

MITSUBISHI ELECTRIC CORPORATION

HEAD OFFICE : TOKYO BLDG MARUNOUCHI TOKYO 100-8310